



Centrifugal Single and Multistage Pumps

CSM series

Standard design

CSM Series, extremely robust stainless steel pumps designed for high pressure duties with medium to low flow rates; especially suitable for applications with high suction or system pressures.

Made from solid CF-3M 1.4404 / AISI 316L stainless steel, the wetted parts have a high surface finish and electro-chemical polish.

Single-stage and multistage models with up to 4 impellers.

Flow rates up to 50 m³/h, heads up to 150 m (15 bar) for the multistage versions.

Flow rates up to 150 m³/h, heads up to 60 m (6 bar) for the single-stage versions.

Design pressure 40 bar.

Temperature range: 0 to 100°C.

Available in three different versions.

Standard CSM: Close coupled design using a standard motor, with a separate pump shaft supported by bearings.

"X" version: Close coupled to a standard motor, with a foot mounted housing containing single or double shaft support bearings.

"K" version: Designed with a separate pedestal containing double shaft support bearings, for use with a flexible coupling and mounting on to a base plate.

Seals:

Protected, balanced and bi-directional mechanical seals with seats to EN 12756, ISO 3069 standards.

Single internal mechanical seal

Single internal flushed mechanical seal

Elastomers (certified to FDA):

EPDM

Fluorocarbon (Viton)

Connections:

Flanges EN 1092-1 PN 40

Clamp for high pressures

DIN 11851 / 11864-1 up to 25 bar



Multistage CSM pump version X



Single-stage CSM pump

CSM MULTISTAGE GENERAL DIAGRAM

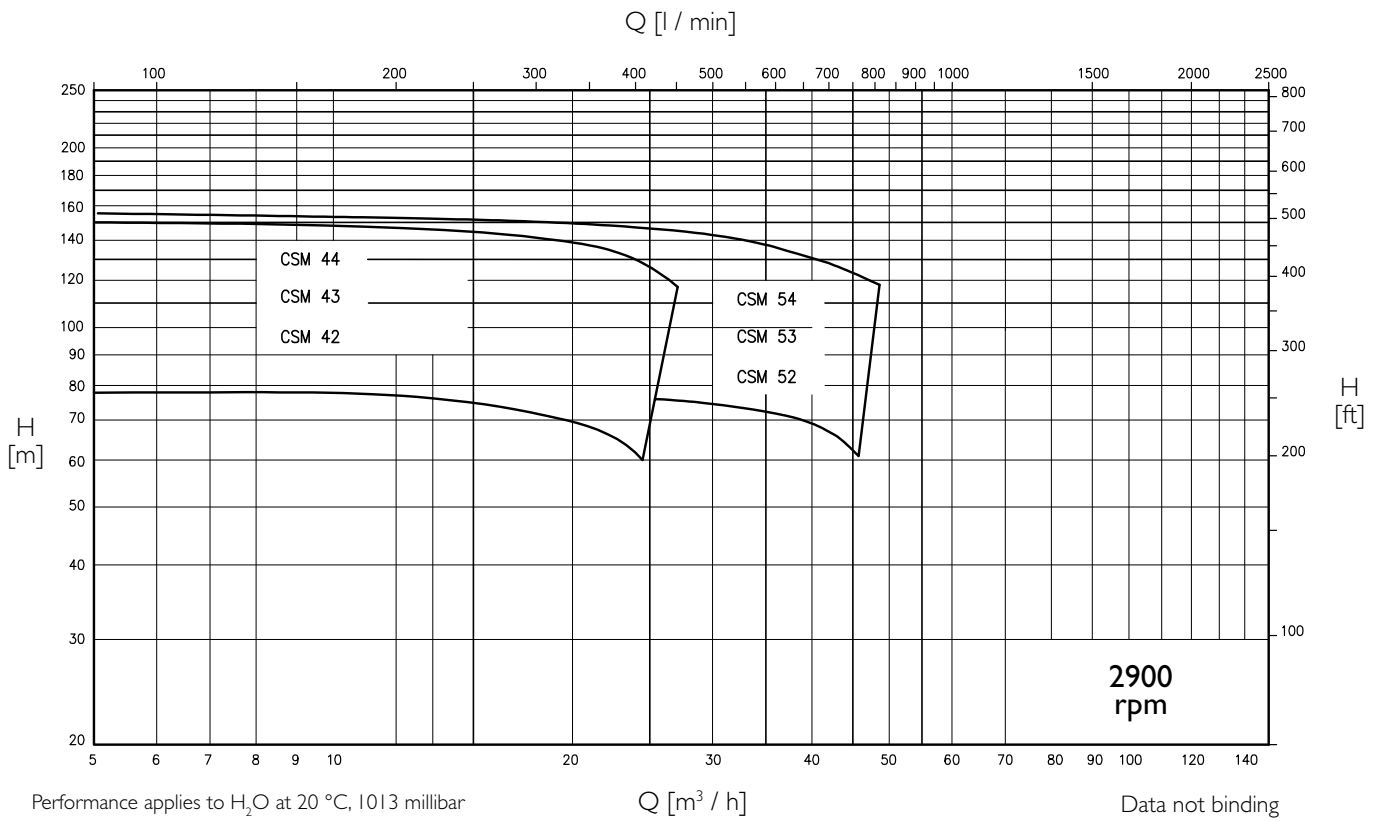

CSM SINGLE-STAGE GENERAL DIAGRAM

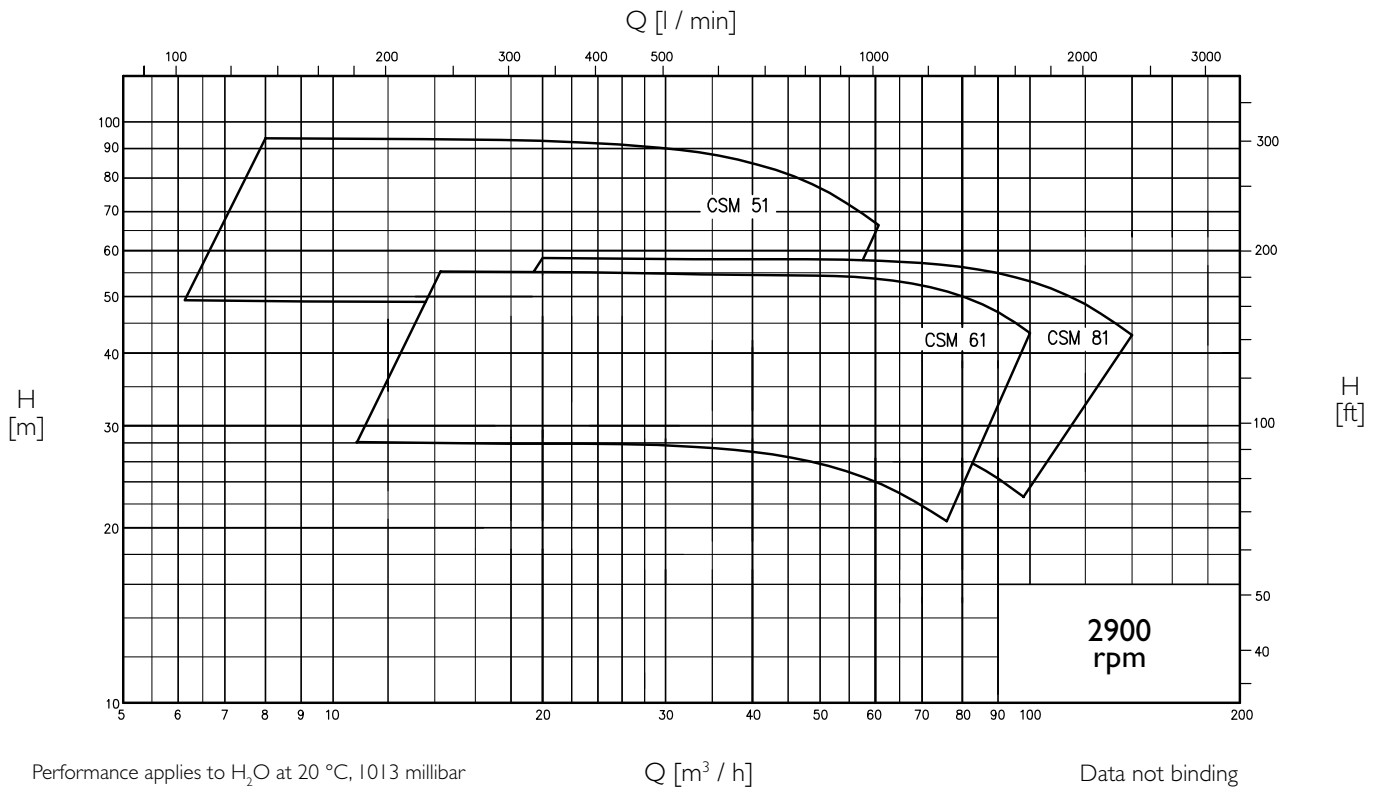

CSM MULTISTAGE OVERALL DIMENSIONS

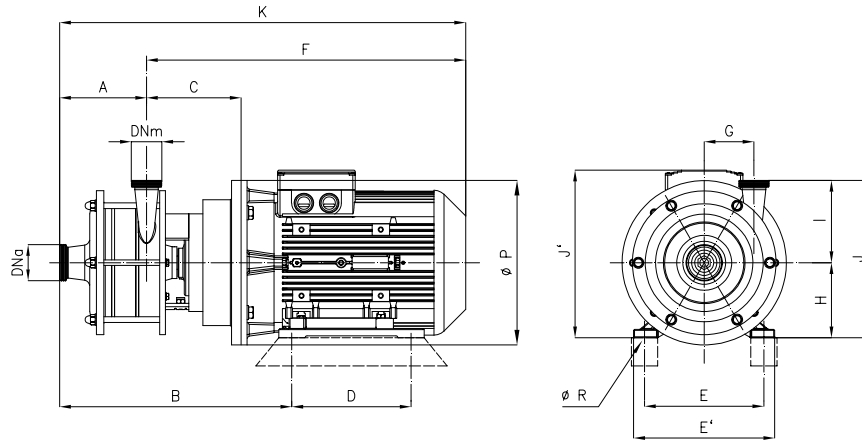

Dimensions not binding - DN = DIN 11851 male threaded connections, with standard IEC/EN motors

Pump	2900 rpm	kW	DNa	DNm	A	B	C	D	E	E'	F	G	H	K	$\varnothing P$	$\varnothing R$	I	J	J'
CSM 42		11	50	40	139	463	216	210	254	300	694	86	160	883	350	14	203	363	357
CSM 42		18,5	50	40	139	463	216	254	254	300	694	86	160	883	350	14	203	363	357
CSM 43		18,5	50	40	192	516	216	254	254	300	694	86	160	886	350	14	203	363	357
CSM 43		22	50	40	192	529	216	241	279	340	776	86	160	968	350	14	203	363	442
CSM 44		22	50	40	245	582	216	241	279	340	776	86	180	1021	350	14	203	383	442
CSM 52		15	65	50	139	463	216	210	254	300	694	86	160	833	350	14	205	365	357
CSM 53		22	65	50	192	529	216	241	279	340	776	86	180	968	350	14	205	385	442

“X” version

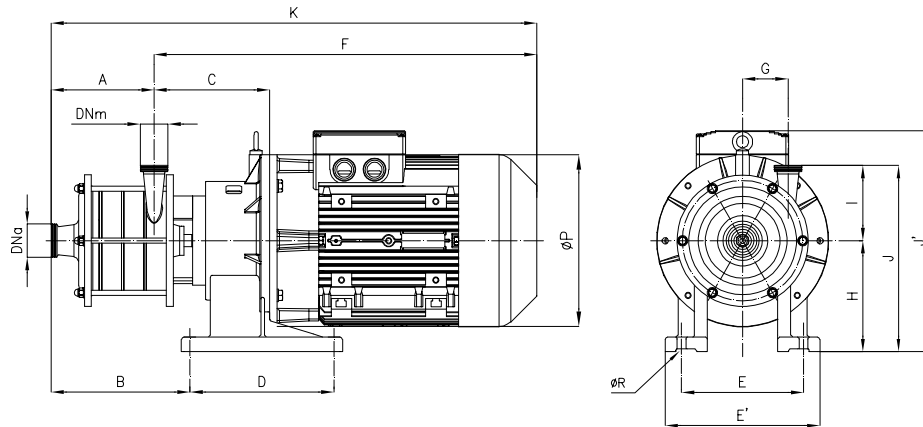

Dimensions not binding - DN = DIN 11851 male threaded connections, with standard IEC/EN motors

Pump	2900 rpm	kW	DNa	DNm	A	B	C	D	E	E'	F	G	H	K	$\varnothing P$	$\varnothing R$	I	J	J'
CSMX 44		30	50	40	245	345	284	335	284	360	943	86	258	1188	400	21	203	461	563
CSMX 53		30	65	50	192	292	284	335	284	360	943	86	258	1135	400	21	205	463	563
CSMX 54		30	65	50	245	345	284	335	284	360	943	86	258	1188	400	21	205	463	563
CSMX 54	37	65	50	245	345	284	335	284	360	943	86	258	1188	400	21	205	463	563	

CSM SINGLE-STAGE OVERALL DIMENSIONS

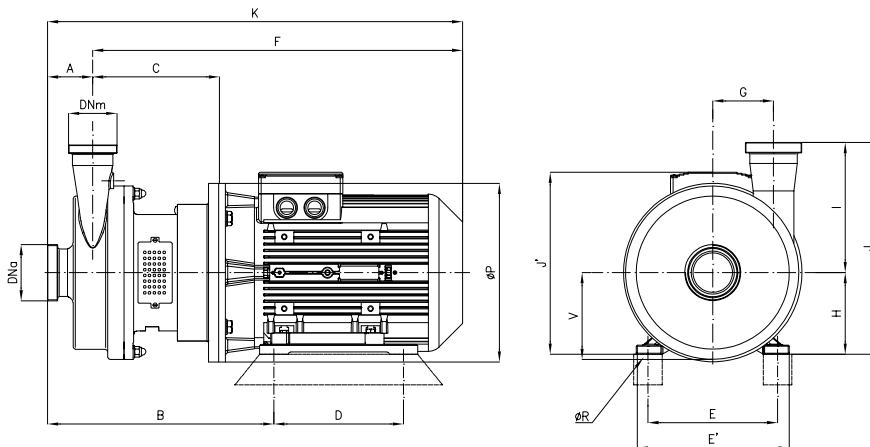

Dimensions not binding - DN = DIN 11851 male threaded connections, with standard IEC/EN motors

Pump	2900 rpm	kW	DNa	DNm	A	B	C	D	E	E'	F	G	H	K	ØP	ØR	I	J	J'	V
CSM 51		15	65	50	73	431	250	210	254	300	728	140	160	801	350	15	240	400	357	195
CSM 51		18,5	65	50	73	431	250	254	254	300	728	140	160	801	350	15	240	400	357	195
CSM 51		22	65	50	73	444	250	241	279	340	813	140	180	883	350	15	240	420	442	195
CSM 61		11	80	65	84	445	253	210	254	300	731	100	160	815	350	15	250	410	357	170
CSM 61		15	80	65	84	445	253	210	254	300	731	100	160	815	350	15	250	410	357	170
CSM 61		18,5	80	65	84	445	253	254	254	300	731	100	160	815	350	15	250	410	357	170
CSM 61		22	80	65	84	458	253	241	279	340	813	100	180	897	350	15	250	430	442	170
CSM 81		11	100	80	100	461	253	210	254	300	731	120	160	831	350	15	255	415	357	170
CSM 81		15	100	80	100	461	253	210	254	300	731	120	160	831	350	15	255	415	357	170
CSM 81		18,5	100	80	100	461	253	254	254	300	731	120	160	831	350	15	255	415	357	170
CSM 81	22	100	80	100	474	253	241	279	340	813	120	180	913	350	15	255	430	442	170	

"X" version

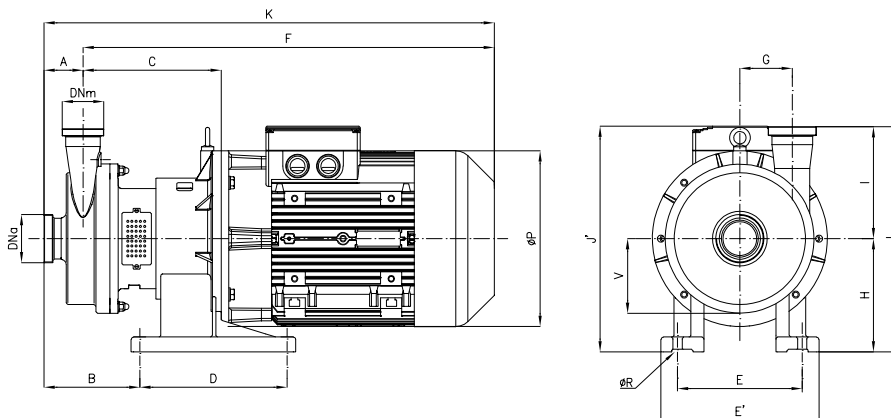

Dimensions not binding - DN = DIN 11851 male threaded connections, with standard IEC/EN motors

Pump	2900 rpm	kW	DNa	DNm	A	B	C	D	E	E'	F	G	H	K	ØP	ØR	I	J	J'	V
CSMX 51		30	65	50	73	216	325	335	284	360	935	140	258	1008	400	21	240	498	558	195
CSMX 61		30	80	65	84	227	328	335	284	360	938	100	258	1022	400	21	250	508	558	170
CSMX 81		30	100	80	100	243	328	335	284	360	938	120	258	1038	400	21	255	513	558	170
CSMX 81	37	100	80	100	243	328	335	284	360	938	120	258	1038	400	21	255	513	558	170	



C.S.F. Inox S.p.A. Strada per Bibbiano, 7 - 42027 Montecchio E. (RE) - ITALY EU
 Ph +39.0522.869911 ra. - Fx +39.0522.865454 / 866758 - csfitalia@csf.it - www.csf.it

Export Department • Commercial Étranger • Comercial Extranjero
 Ph +39.0522.869922 - Fx +39.0522.869841 - csfexport@csf.it - www.csf.it

All the instructions, data and representations (in whatever way executed) listed in this publication are indicative and do not binding. C.S.F. does not stand surety or undertake any obligation for the utilisation of this document and for the information contained. In particular, it does not guarantee against omissions or errors of the data and drawings here indicated.
 Notice that the technical specifications, information and representations in this document are merely indicative and approximate. C.S.F. INOX reserves the right at any moment and without notice to modify the data, drawings and information indicated in this document.