

























# SED Flow Control GmbH

## Valves for aseptic Applications

PRODUCTCATALOG

# Overview Aseptic Valves

|   | Steripur  | KMA  | KMD   |
|---|---|--|---|
| <b>Size</b>   | <b>Manual</b>   |  |   |
| MA 8<br>DN 4-15mm   | Type 206<br>Page 34<br>                | Type 205<br>Page 48, 49<br>              |   |
| MA 10<br>DN 8-20mm  | Type 397<br>Page 35<br>                | Type 295<br>Page 50, 51<br>              | Type 289<br>Page 60<br>                  |
| MA 25-50<br>DN 15-50mm  | Type 907<br>Page 36<br>                | Type 905<br>Page 52, 53<br>              | Type 982<br>Page 61<br>                  |
| MA 80-100<br>DN 65-100mm  | Type 997<br>Page 37<br>               | Type 995<br>Page 54<br>                 | Type 985<br>Page 62<br>                 |
|   | <b>Pneumatically operated</b>   |  |   |
| MA 8<br>DN 4-15mm   | Type 217<br>Page 38, 39<br>          | Type 190<br>Page 55<br>                |   |
| MA 10<br>DN 8-20mm  | Type 317<br>Page 40<br>              | Type 195<br>Page 56<br>                | Type 188<br>Page 63<br>                |
| MA 25-50<br>DN 15 -50mm   | Type 417<br>Page 42, 43<br>          | Type 395<br>Page 57<br>                | Type 402<br>Page 64<br>                |
| MA 25-80 <sup>1</sup><br>MA 25-100 <sup>2</sup><br>MA 80-100 <sup>3</sup><br>DN 15-100mm <sup>1,2</sup><br>DN 65-100mm <sup>3</sup> | Type 407 <sup>3</sup><br>Page 41<br> | Type 495 <sup>1,2</sup><br>Page 58<br> | Type 385 <sup>1,2</sup><br>Page 65<br> |

Detailed diaphragm valve overview see page 26 - 27

|          |   |  |
|----------|---|--|
| <b>1</b> | <b>Introduction</b><br>Overview   | Page<br>4 - 11   |
| <b>2</b> | <b>Media Contacted Components</b><br>Diaphragms<br>Valve Bodies (fold out page)<br>Butt Weld Tube Ends (fold out page)<br><b>Aseptic Connections</b>  | 14 - 19<br>20<br>21<br><b>22 - 24</b>  |
| <b>3</b> | <b>Aseptic Diaphragm Valves</b><br><b>Overview Diaphragm Aseptic Valves</b><br>Why Aseptic Diaphragm Valve?<br>Self Draining - Two-Way Valve<br>Innovative Design<br><b>Aseptic Diaphragm Valves</b><br>STERIPUR Series<br>KMA Series<br>KMD Series<br><b>Ordering Key and Ordering Example</b>   | 26, 27<br>28<br>29<br>30 - 33<br>34 - 46<br>48 - 58<br>60 - 65<br>66 - 68        |
| <b>4</b> | <b>Aseptic Diaphragm Valve Configurations</b><br><b>D-Rule</b><br><b>Welded Valve Configurations</b><br><b>Multiport Valves</b><br>Why Multiport Valves?<br>Main line open, Loop Valves (e.g. T-Valve)<br>All lines and valve ports able to close<br>The way of customized multiport valve designs<br>Specification Multiport Valves<br><b>Tank Valves</b><br><b>Process Solutions</b><br>Sterile Sampling Unit<br>Purified Steam Sampling Unit | 72<br>73 - 75<br>76<br>77 - 81<br>82 - 87<br>88<br>89<br>90 - 93<br>94<br>95     |
| <b>5</b> | <b>Angle Seat Valves</b><br>Description and Features<br>Technical Data<br>Regulating cone<br>2/2-Way Angle Seat Valves<br>Valve Body Dimensions<br>Ordering Key and Ordering Example  | 98, 99<br>100 - 101<br>102 - 105<br>106 - 114<br>115 - 117<br>118, 119           |
| <b>6</b> | <b>Ball Valves</b><br>Manual Ball Valve Description and Features<br>Pneumatically Ball Valve Description and Features<br>Technical Data<br>Ordering Key   | 123<br>124<br>125 - 128<br>129   |
| <b>7</b> | <b>System Components and Process Automation</b><br><b>Overview</b><br>Manual Adjustment - Optical Indication<br>Electrical Switch Boxes - Pilot Control<br><b>Detailed Information</b><br>3/2 Way Plastic Pilot Valve<br>Control Head Switch 024.63. - 024.89.<br>Contact-Free Limit Switch 024.50<br><b>Process Automation, Electropneumatic Positioners</b><br><b>Overview Product Range</b><br><b>Glossary</b>                               | 132<br>133<br>134<br>135, 136<br>137<br>138, 139<br>140 - 143<br>144<br>145, 146 |



# A Brief Overview

**SAMSON** operates wherever there is controlled flow of oils, gases, vapors or chemical substances. Valves are our core business. With our valves, we are active in a market that has enormous potential for future innovations. We are further expanding the valves' decentralized intelligence. By developing new, smart systems, we are transforming process automation to the benefit of our customers and to achieve greater flexibility, safety and reliability in industrial processes.

Founded in 1907, SAMSON has grown into a world leading valves manufacturer with more than 600 million euros sales and 4500 employees in 50 subsidiaries all around the world.

**SED Flow Control** is an international operating company, leading in the development, production and worldwide sales of sophisticated valve technologies.

SED Flow Control was established in 1984 and became a member of the SAMSON Group in 2017. Thanks to the powerful support of a world leading valve company we are well prepared to all future challenges. Our mission is to provide high quality products for the life science and industrial market. A clearly defined range of products, our flexibility and our proximity to the clients are factors of considerable importance for our customers.

Our highly motivated employees in product management, engineering, sales and all other departments are pleased to work with our customers' challenges. Whether it is a big volume order, a short delivery time, or just an opportunity to find the most efficient process valve solution, SED is ready to take this challenge.

## Our Advantages:

- Highly qualified employees with many years of experience in the development and manufacturing of valve components and systems.
- Valve technologies with an innovative design and creative customized solutions.
- Modular and compact assembly of our products.
- High vertical range of manufacturing allows for a high degree of flexibility.
- Comprehensive selection of accessories for valve monitoring and regulation.
- International sales network and a dedicated internal sales staff.



Headquarter SAMSON AG Frankfurt (Main)



The office building is connected to the production building for direct communication with manufacturing.



Production building

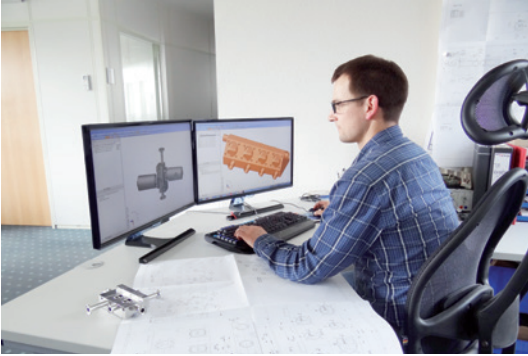

CAD- CAM working station

The company has installed the most modern machinery and individual production facilities which are fully adapted to current market requirements.

Specifically:

- The 3D-CAD-CAM network connects all the CAD workstations with the 3 and 5 axis CNC machining facilities, bringing our products from conception to development.
- Injection molding manufacturing, special injection molding machines, and tools adapted to high performance plastics and specific processes.
- Assembly in clean room facilities with ultrasonic clean washing including other automated assembly capabilities.
- Work stations which are ergonomically designed for the health and safety of our employees.
- Programmable welding machine and polishing work stations for aseptic diaphragm valves in order to guarantee the greatest flexibility and quality.



Ultrasonic cleaning of valve bodies



Valve cluster assembled with patent Steripur and KMA actuation



CNC machining center

# What Does Quality Mean at SED?

The complete satisfaction of our customer is our ultimate benchmark for quality. Only then, may a successful and sustained existence in the market be guaranteed.

The prerequisite for quality is not only a functional product but also that the quality concept is applied comprehensively to all areas of our business. This includes research and development, production, suppliers, services and our sales team.

## The Fundamental Areas of Our Quality Policy:

### Products and Services:

An accelerated implementation of customized solutions is achieved with personal conversations and direct customer input.

This is supported by the specialization of SED through development and production areas with efficient experience and extensive training requirements.



Process system application with standard and multiport compact customized valve solutions

### Suppliers:

The quality of our products is directly dependent on the performance of our suppliers.

Through a supplier qualification process, continuous assessments are performed, documented and form the basis of a close customer-supplier-relationship.



Spectrometer and RFA material analysis

### Work Sequences:

For each individual step of the manufacturing process the motto "My colleague is my customer" applies. This means that everybody has to handle their production responsibility in a way that the internal customer is satisfied and that their best work is possible.

### Customers:

Our customer is our employer and should see their visions and wishes realized. This means that our goal is to work together with our customers to develop solutions and implement these solutions with cost effective results.

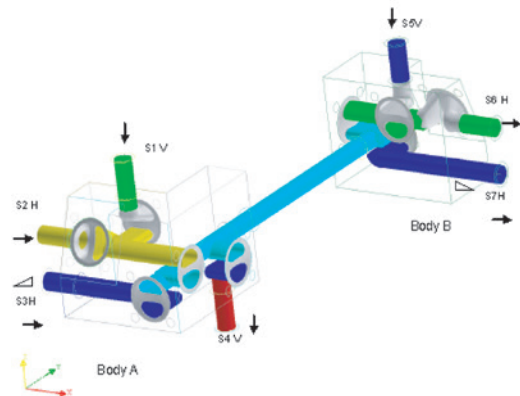

3D modeling and flow direction of a multivalve cluster

### Employees:

The greatest asset of our company is our employees. Embracing quality is not the result of an individual but the outcome of successful teamwork. The ability to develop new ideas, to take on responsibility and to show initiative and creativity brings us continuous development and improvement. Each level of the company believes in our quality and growth philosophy and this is reinforced with continued education.



## Certified Process Qualification

- Quality Management System ISO 9001
- Environment Management System ISO 14001
- Energy Management System ISO 50001
- Manufacturing Process AD2000 Merkblatt HP0
- Pressure Equipment Directive 2014/68/EU
- Specialised Company for Welding ISO 3834-2
- Qualified Personnel for Material Traceability according §2 Abs.2a Gerätesicherungs-gesetz

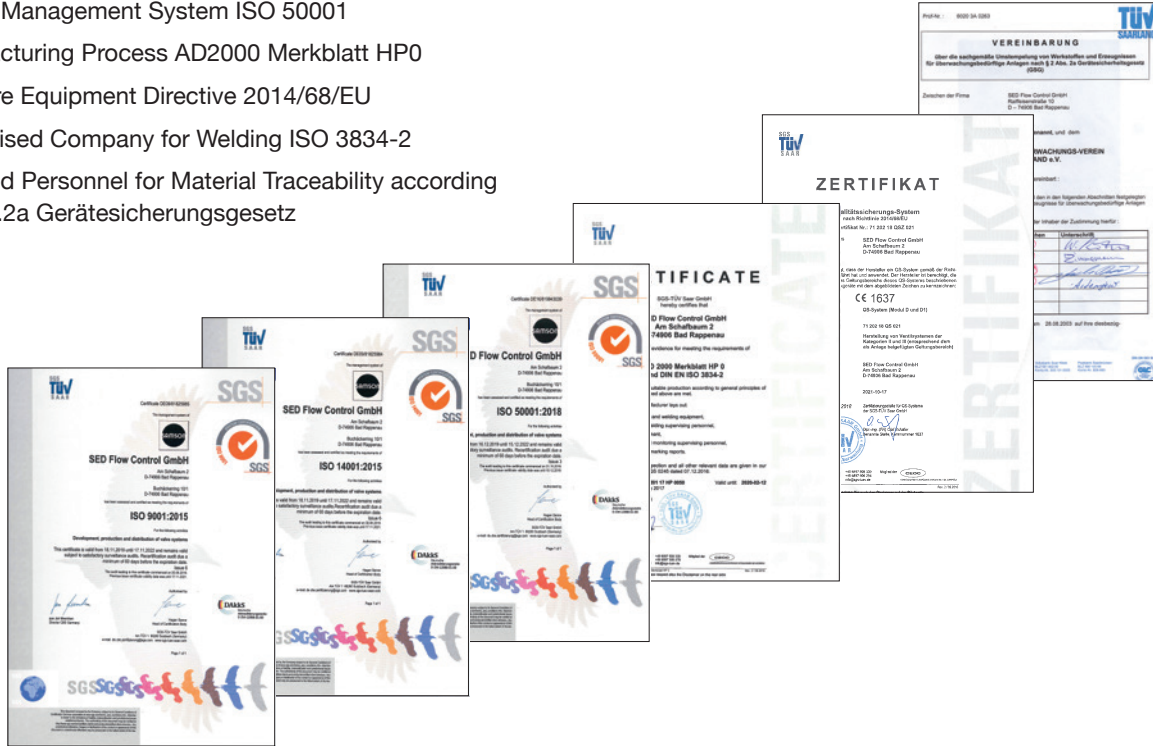

## Validation for the Aseptic Diaphragm Valve

- Compliance to 3-A Standard Section 54-02
- Compliance to CRN Canadian Standards Association
- Certification of Compliance according to EN 10204 2.2
- Certification of Compliance according to EN 10204 3.1
- Certification of an assessment according 2014/34/EU
- TA-Luft / VDI 2440 / VDI 3479

Note: Certification and compliance for valve diaphragm and valve body see the corresponding sections in the catalogue

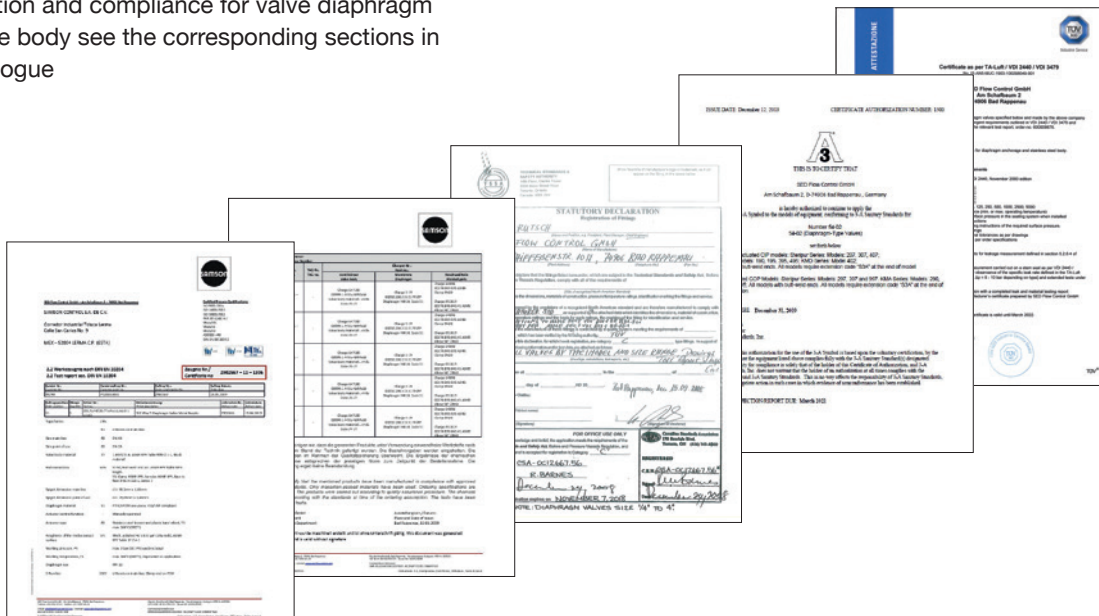



In order to design valves for a process system correctly, the valve size is determined by the required flow rate. The  $K_V$ -value serves as a calculation basis for the different process conditions. This value is stated in the following table with regard to nominal diameter and standards.

## $K_V$ -value

The  $K_V$ -value is a parameter defining the flow rate of valves. It describes the amount of water from 5° to 30°C which flows through the valve at a pressure loss of 1 bar. The  $K_{VS}$ -value describes the  $K_V$ -value when the valve is 100% open.

For water 5-30°C applies:

$$K_V = \frac{Q}{\sqrt{\Delta p}}$$

General Liquid Flow Formula:

$$K_V = Q \sqrt{\frac{\rho}{1000 \Delta p}}$$



Test stand to determine and document flowrates and  $K_V$  ( $C_V$ ) values

## Conversion:

For the correct  $K_V$  to  $C_V$  conversion calculation, use only the stated units formulas below.

The  $K_V$ -value must be converted from (cubic meter / hour) by utilizing the following conversion factors.

In the US the flow rate of water is measured with the  $C_V$ -value in US-gallons per minute (gpm) with a pressure drop of  $\Delta p$  1 PSI.

Conversion of  $K_V$  in  $C_V$   
 $C_V = 1,17 \times K_V$

Conversion of  $C_V$  in  $K_V$   
 $K_V = 0,86 \times C_V$

## Explanations:

|            |                   |                                 |
|------------|-------------------|---------------------------------|
| $K_V$      | m <sup>3</sup> /h | flow rate parameter             |
| Q          | m <sup>3</sup> /h | volume flow rate                |
| $\rho$     | kg/m <sup>3</sup> | specific gravity                |
| $p_1$      | bar               | pressure before the valve       |
| $p_2$      | bar               | pressure after the valve        |
| $\Delta p$ | bar               | pressure drop through the valve |
|            |                   | $\Delta p = p_1 - p_2$          |

| $K_{VS}$ -Value (m <sup>3</sup> /h) |       |     | Nominal diameter    |                         |                     | Valve type   |
|-------------------------------------|-------|-----|---------------------|-------------------------|---------------------|--|
| DN                                  | NPS   | MA  | ISO 1127<br>Code 40 | DIN 11850<br>Code 41-42 | ASME-BPE<br>Code 45 |  |
| 4                                   | -     | 8   | -                   | -                       | -                   | 190/205/206/207<br>217/290/297                         |
| 6                                   | -     | 8   | -                   | -                       | -                   |  |
| 8                                   | 1/4   | 8   | 2,4                 | -                       | 0,7                 |  |
| 10                                  | 3/8   | 8   | -                   | 2,3                     | 1,4                 |  |
| 15                                  | 1/2   | 8   | -                   | -                       | 2,0                 |  |
| 8                                   | 1/4   | 10  | 2,7                 | -                       | -                   | 188/195/295<br>289/317/392<br>394/397                  |
| 10                                  | 3/8   | 10  | 3,9                 | 2,5                     | 1,4                 |  |
| 15                                  | 1/2   | 10  | 5,3                 | 4,7                     | 2,2                 |  |
| 20                                  | 3/4   | 10  | -                   | 5,5                     | 4,6                 |  |
| 15                                  | 1/2   | 25  | 10,5                | 9,5                     | -                   | 385/395/402/407/417/495/592<br>905/907/982/985/995/997 |
| 20                                  | 3/4   | 25  | 13,0                | 11,5                    | 6,8                 |  |
| 25                                  | 1     | 25  | 15,5                | 14,2                    | 12,0                |  |
| 32                                  | 1 1/4 | 40  | 43,0                | -                       | -                   |  |
| 40                                  | 1 1/2 | 40  | 50,0                | 43,0                    | 40,0                |  |
| 50                                  | 2     | 50  | 64,0                | 52,0                    | 48,0                |  |
| 65                                  | 2 1/2 | 80  | 95,0                | 89,0                    | 85,0                |  |
| 80                                  | 3     | 80  | 127,0               | 123,0                   | 110,0               |  |
| 100                                 | 4     | 100 | 205                 | 192,0                   | 185,0               |  |

The  $K_{VS}$ -Values in the table refer to the specification with Two-Way valve bodies with EPDM diaphragm (Depending on the specification variations are possible).

The  $K_{VS}$ -Values with PTFE diaphragm maybe lower due to higher stiffness of the material, particularly in applications with lower working pressure.

The consistency of the interior surface has a great impact on the quality of an aseptic system process. By means of polishing, the interior contact surface is reduced. The specified surface quality of the valve body is achieved through mechanical polishing and electro polishing. According to the standards SED offers surfaces with a surface finish up to a quality of 0,25  $\mu\text{m}$  and 10 Ra. At SED the stated surface finish always describes the maximum surface roughness value.

The surface finish is reached by automatic or manual mechanical polish processing. The methods that are applied depend on the internal contour and size of the valve body.

The surfaces of the valve bodies with the highest quality are produced through polishing with different grit sizes up to size 400.

The advantages of premium surfaces are a smoother interior surface as well as the reduction of the contact between the surface and the process medium.

Thus a more efficient cleaning and sterilization, lower risk of contamination by process fluids, and lower danger of product adhesion to the interior surface is achieved.

## Electro Polishing

Electro polishing is an electrochemical process where the polishing part serves as anode and for example, copper as electrode.

The valve body is submerged into an electrolyte solution and a voltage between 2 and 25 volts is charged.

Through the current a strong chemical reaction develops which removes material from the anode.

According to the standardized procedure, the process has to be controlled in a way that at least 20  $\mu\text{m}$  of surface material is removed.

The highest metal removal is achieved at the peaks of the metal surface.

## Reasons for Electro Polishing

- High lustrous appearance
- Smoothing of the peaks of the surface finish
- Reduction of the surface tension and adhesion of the process medium
- Removal of non-metallic inclusions
- Improved corrosion resistance through accumulation of chromium of the surface

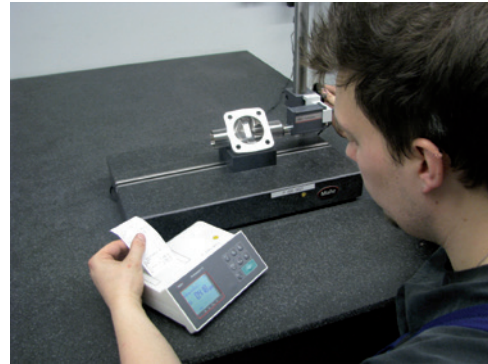

The surface finish, roughness, is measured and recorded at defined reference points according to DIN EN ISO 4287.

## Microscopic view:

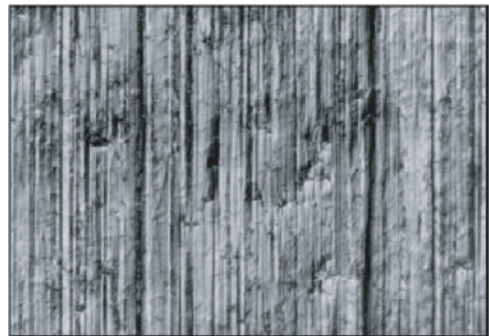

Microscopic view of mechanically polished surface with grit 400 Ra 0,25  $\mu\text{m}$  / 10  $\mu\text{-inch}$

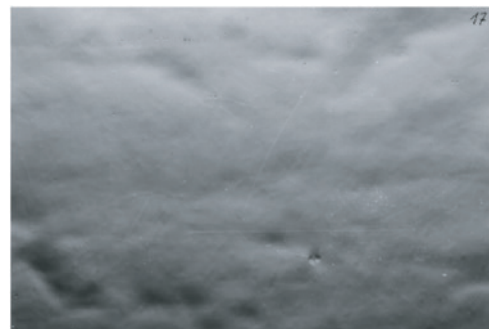

Microscopic view of mechanically polished and electro polished Ra 0,25  $\mu\text{m}$  / 10  $\mu\text{-inch}$

## Ra-Value

The arithmetic average Ra is used as parameter for the surface finish profile.

$L_t = 5,6$  mm traversing length and  $l_n = 4,0$  mm measuring range split in 5 single measuring sections  $l_r = 0,8$  mm each measured transverse to the polished image.

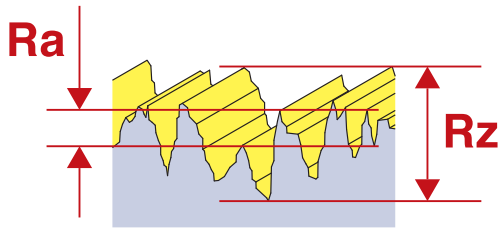

## Tape Print Out of Surface Finish

```

Perthometer M1
Objekt
Name
#
Lt (AUTO)    5.600 mm
Lc           0.800 mm
Ra           0.484 µm
Rz           3.37 µm
Rmax         3.77 µm
R Pc(0.5,-0.5) 108 /c

R Profil
Lc           0.800 mm
VER          2.50 µm
    
```

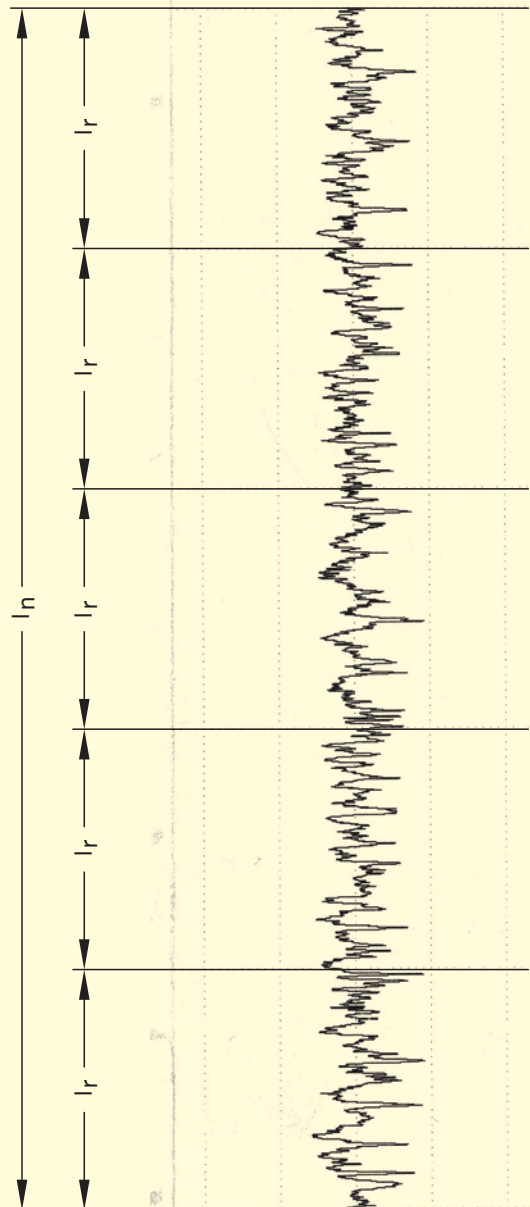

## Definition of the SED codes for Ra-Values

Allocation to the standard DIN 11866:

| SED  |        | DIN 11866     | Mechanically Polished | Mechanically Polished and Electro-polished |
|------|--------|---------------|-----------------------|--|
| Code | Ra max | hygiene class |                       |  |
| 02   | 0,8    |               | •                     |  |
| 03   | 0,8    | HE3c          |                       | •  |
| 07   | 0,6    |               | •                     |  |
| 08   | 0,6    |               |                       | •  |
| 09   | 0,4    |               | •                     |  |
| 10   | 0,4    | HE4c          |                       | •  |
| 14   | 0,25   |               | •                     |  |
| 16   | 0,25   | HE5c          |                       | •  |

Allocation to the standard ASME BPE Table SF-2.4-1:

| SED and ASME BPE | Ra max                |      | Mechanically Polished | Mechanically Polished and Electro-polished |
|------------------|-----------------------|------|-----------------------|--|
|                  | µ-inch                | µm   |                       |  |
| SF0              | No Finish Requirement |      |                       |  |
| SF1              | 20                    | 0,51 | •                     |  |
| SF2              | 25                    | 0,64 | •                     |  |
| SF3              | 30                    | 0,76 | •                     |  |
| SF4              | 15                    | 0,38 |                       | •  |
| SF5              | 20                    | 0,51 |                       | •  |
| SF6              | 25                    | 0,64 |                       | •  |



|          |   |  |
|----------|---|--|
| <b>1</b> | <b>Introduction</b><br>Overview   | Page<br>4 - 11   |
| <b>2</b> | <b>Media Contacted Components</b><br>Diaphragms<br>Valve Bodies (fold out page)<br>Butt Weld Tube Ends (fold out page)<br><b>Aseptic Connections</b>  | 14 - 19<br>20<br>21<br><b>22 - 24</b>  |
| <b>3</b> | <b>Aseptic Diaphragm Valves</b><br><b>Overview Diaphragm Aseptic Valves</b><br>Why Aseptic Diaphragm Valve?<br>Self Draining - Two-Way Valve<br>Innovative Design<br><b>Aseptic Diaphragm Valves</b><br>STERIPUR Series<br>KMA Series<br>KMD Series<br><b>Ordering Key and Ordering Example</b>   | 26, 27<br>28<br>29<br>30 - 33<br>34 - 46<br>48 - 58<br>60 - 65<br>66 - 68        |
| <b>4</b> | <b>Aseptic Diaphragm Valve Configurations</b><br><b>D-Rule</b><br><b>Welded Valve Configurations</b><br><b>Multiport Valves</b><br>Why Multiport Valves?<br>Main line open, Loop Valves (e.g. T-Valve)<br>All lines and valve ports able to close<br>The way of customized multiport valve designs<br>Specification Multiport Valves<br><b>Tank Valves</b><br><b>Process Solutions</b><br>Sterile Sampling Unit<br>Purified Steam Sampling Unit | 72<br>73 - 75<br>76<br>77 - 81<br>82 - 87<br>88<br>89<br>90 - 93<br>94<br>95     |
| <b>5</b> | <b>Angle Seat Valves</b><br>Description and Features<br>Technical Data<br>Regulating cone<br>2/2-Way Angle Seat Valves<br>Valve Body Dimensions<br>Ordering Key and Ordering Example  | 98, 99<br>100 - 101<br>102 - 105<br>106 - 114<br>115 - 117<br>118, 119           |
| <b>6</b> | <b>Ball Valves</b><br>Manual Ball Valve Description and Features<br>Pneumatically Ball Valve Description and Features<br>Technical Data<br>Ordering Key   | 123<br>124<br>125 - 128<br>129   |
| <b>7</b> | <b>System Components and Process Automation</b><br><b>Overview</b><br>Manual Adjustment - Optical Indication<br>Electrical Switch Boxes - Pilot Control<br><b>Detailed Information</b><br>3/2 Way Plastic Pilot Valve<br>Control Head Switch 024.63. - 024.89.<br>Contact-Free Limit Switch 024.50<br><b>Process Automation, Electropneumatic Positioners</b><br><b>Overview Product Range</b><br><b>Glossary</b>                               | 132<br>133<br>134<br>135, 136<br>137<br>138, 139<br>140 - 143<br>144<br>145, 146 |

# Diaphragms

The diaphragm is the most important component that determines the performance characteristics of a diaphragm valve. You could say the diaphragm is the heart of our valve. It is the dynamic part that controls and closes the flow of the process medium. At the same time, the diaphragm is the only part that is in contact with the process medium besides the valve body and separates the medium area from the actuator side and the atmospheric environment.

The development of the formulation for the elastomer compounds for our diaphragms is carried out in close cooperation with a highly specialized company which has been developing, testing and producing diaphragm formulations for aseptic applications together with SED for many years.

All diaphragms for aseptic applications used by SED have been tested and developed over many years on our own test benches and at third parties under a wide range of application-related operating conditions.

By purchasing and installation our new Test bench we brought this very high level of development to a higher one.

In our bench, process conditions such as those that exist in the pharmaceutical and food industries can be realistically simulated, thus enables us finding the latest development of new valve diaphragms to be obtained.

In addition to these test scenarios, which reproduce customer-specific applications, tests can also be carried out on this bench, which have become so to speak industrial standards. Here, for example, the extensive tests described in the ASME BPE should be mentioned.

With these and the possibilities offered by the Rolf Sandvoss Innovation Center based at our headquarter SAMSON AG FFM, we are well prepared for future challenges.



Process test bench. Cycle and lifetime testing of diaphragms and valves with saturated steam and various cip media.

| Material          |      | EPDM                  |    | PTFE/EPDM             |       | PTFE/EPDM                |
|-------------------|------|-----------------------|----|-----------------------|-------|--------------------------|
| MA                |      | 8 - 100               |    | 25, 40, 50            | 8, 10 | 25 - 100                 |
| Design            |      | One-piece molded open |    | One-piece molded open |       | two-pieces molded closed |
| Temperature range | (°C) | -40 to 150            |    | -20 to 150            |       | -20 to 160               |
|                   | (°F) | -40 to 300            |    | -4 to 300             |       | -4 to 300                |
| SED Code          |      | 20                    | 28 | 30                    | 51    | 44                       |

The listed temperatures may apply to clean steam sterilization protocols and may not apply to continuous steam service. Upon request, other diaphragms are available with other materials, bigger sizes and for higher temperature up to 175°C/350°F.



Elastomer

## EPDM

Ethylene-propylene elastomer peroxide cured. The SED EPDM is a specifically developed compound reinforced with a vulcanized woven fabric inlay and is always manufactured in the molded open position. This diaphragm construction achieves higher stability for the diaphragm at elevated temperatures and pressures. In addition, the woven fabric inlay is vulcanized over the embedded compressor stud in order to strengthen the elastomer-metal connection. Thus, the EPDM diaphragm is ideal for vacuum applications.

## PTFE (TFM)

These PTFE diaphragms have been designed and offer the highest degree of chemical resistance, increased stability, longer flex life, less porosity, reduced cold flow and superior performance through temperature fluctuations between hot and cold and steam sterilization cycles.

## MA8 and MA10

The diaphragm dimensions MA8 and MA10 are designed as one-piece diaphragms: This means that the EPDM back is bonded with the PTFE.

The diaphragm is always manufactured in the molded open position. These one-piece diaphragms have less surface area and are subject to shorter linear strokes which explain the excellent performance that has proved itself over time.

MA8 diaphragm incorporates an elastomer button for assembly with the valve operating mechanism. The MA10 utilizes a threaded stud assembly with the valve operating mechanism. Both these features eliminate the potential for point loading at the center of the diaphragm.

## MA25 to MA100

The diaphragm dimensions MA25 to MA100 are designed as two-piece diaphragms-consisting of a separate EPDM backing cushion and PTFE diaphragm. The diaphragm is always manufactured in the molded closed position. The advantage of this design for the MA25 to MA100 is that the diaphragm is in its molded shape while in the closed position of the valve. This reduces the force to close the valve and increases the life of the diaphragm.

In the two piece diaphragms the threaded stud connection is embedded in the PTFE of the diaphragm. To eliminate the potential of point loading at the center of the diaphragm, a floating suspension connection to the valve operating mechanism is utilized.

**Note:** Other diaphragm sizes and materials on request.



PTFE/EPDM

# Diaphragms

MA 8 - 80:

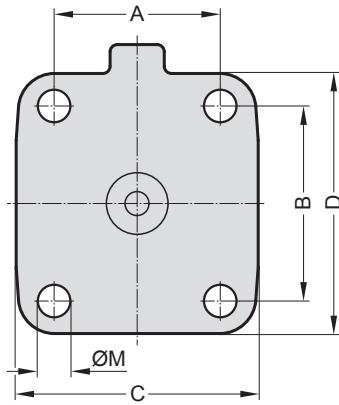

MA 100 - 125:

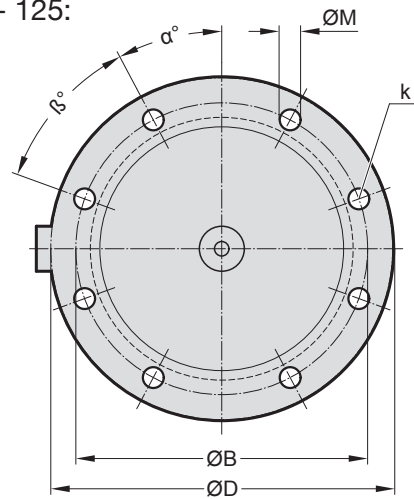

MA 150:

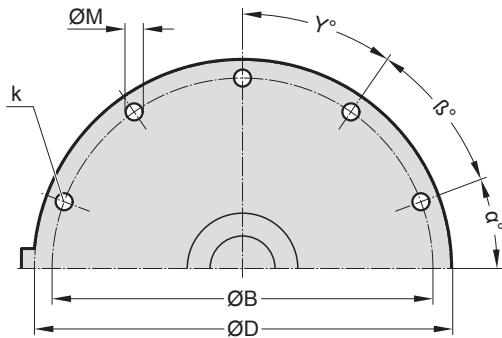

MA 10 - 150:

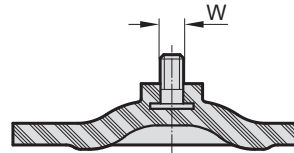

MA 8:

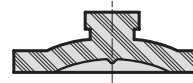

Dimensions (mm)

| DN      | NPS             | MA  | A    | B     | C     | D     | ØM   | k  | W     | α    | β    | γ  |
|---------|-----------------|-----|------|-------|-------|-------|------|----|-------|------|------|----|
| 4 - 15  | 1/4" - 1/2"     | 8   | 22   | 22    | 31,5  | 31,5  | 5,5  | 4  | -     | -    | -    | -  |
| 12 - 15 | 3/8" - 1/2"     | 10  | 42.5 | 37.5  | 52    | 47    | 5.5  | 4  | M4    | -    | -    | -  |
| 15 - 25 | 1/2" - 1"       | 25  | 46   | 54    | 67    | 72    | 9    | 4  | 1/4"  | -    | -    | -  |
| 32 - 40 | 1 1/4" - 1 1/2" | 40  | 65   | 70    | 90    | 100   | 13.5 | 4  | 1/4"  | -    | -    | -  |
| 50      | 2"              | 50  | 78   | 82    | 106   | 124   | 13   | 4  | 1/4"  | -    | -    | -  |
| 65      | 2 1/2"          | 65  | 95.3 | 101.6 | 131.9 | 144.4 | 14.3 | 4  | 5/16" | -    | -    | -  |
| 65 - 80 | 2 1/2" - 3"     | 80  | 114  | 127   | 156   | 186   | 18   | 4  | 5/16" | -    | -    | -  |
| 100     | 4"              | 100 | -    | 194   | -     | 228   | 14.5 | 8  | 5/16" | 20   | 42   | -  |
| 125     | 5"              | 125 | -    | 222   | -     | 254   | 17.5 | 8  | 3/8"  | 43.5 | 43.5 | -  |
| 150     | 6"              | 150 | -    | 273   | -     | 298.5 | 17.5 | 10 | 3/8"  | 35   | 35   | 35 |



## Diaphragm Code 28

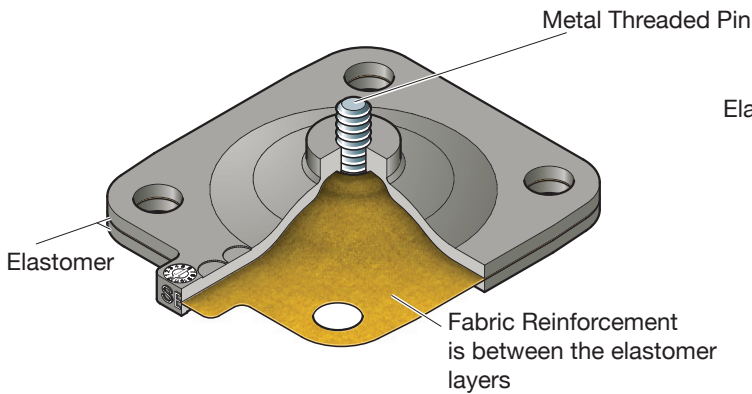

After a long and successful development accompanied by stringent testing, simulation of actual aseptic process applications and sterilization protocol, SED has released an improved elastomer formulation for our EPDM diaphragms. This EPDM diaphragm is produced out of an improved compound material targeting critical aseptic applications with SIP steam sterilizing cycles and processes.

### Features:

- The elastomer formulation for our Code 28 EPDM diaphragm is identical to the Code 20 EPDM diaphragm which has a different design and manufacturing process.
- Woven fabric reinforcement is positioned between two elastomer layers.
- Increased lifetime expectancy under steam.
- All required approvals and conformities are available (See page 18).
- Diaphragm is interchangeable with all SED diaphragm valves.

## Diaphragm Code 20

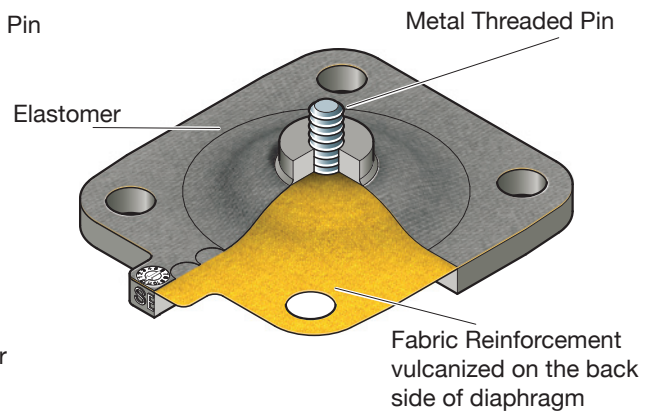

Typically a diaphragm is manufactured with a woven fabric reinforcement positioned in the middle of the EPDM elastomer diaphragm to improve the mechanical properties, strength and durability. This is accomplished by vulcanizing the woven fabric reinforcement between two elastomer layers.

A specific manufacturing process has been developed to vulcanize the woven fabric reinforcement on the back side of the EPDM diaphragm. With this manufacturing process the diaphragm achieves better performance in SIP steam sterilizing cycles and processes with reliability in critical sterile processes.

### Features:

- The elastomer formulation for our Code 20 EPDM diaphragm is identical to the Code 28 EPDM diaphragm.
- The fabric has a maximum distance from the media contact surface.
  - Damage to the fabric can be easily observed.
- Friction between the compressor and the back of the diaphragm is minimized.
  - Therefore reduced wear and longer cycle lifetime.
- Better load distribution because the height of pure elastomer is maximized when the fabric is on the back side.
- Process safety increases because of only one fabric layer. The position of the fabric on the back side is exactly geometrically defined.
- Production control is easier when the fabric is on the back side.
- All required approvals and conformities are available (See page 18).
- Diaphragm is interchangeable with all SED diaphragm valves.



# Diaphragms

## Certification and Compliance for Validation

At SED, we recognize the importance of the validation process in the aseptic industry.

This has led to an internal awareness and specific restructuring within the company to provide the highest level of reliability and regulatory compliance through the complete supply chain to provide a complete package of documentation for all components in contact with the process fluid.

Related to it the key performance component in the diaphragm valve is the diaphragm.

- All resin and additives used in the manufacturing process are FDA compliant.
- Compounding, physical properties and manufacturing process are documented
- Certificate of Conformance with FDA for all diaphragms
  - 21CFR177.2600 for Elastomers
  - 21CFR177.1550 for Perfluorocarbon resins
- Certificate of Conformance with USP 28 Class VI, Chapter 87 In-Vitro and Chapter 88 In-Vivo
- Testing for extractable organic substances on the basis of ISO 10993-18 (detection by GC-MS)
- Certificate of Conformance with 3-A
- TSE/BSE (ADCF) Certification of Compliance to EMEA/410/01 "Guidance on Minimising the Risk of Transmitting Animal Spongiform Encephalopathy Agents via Human and Veterinary Medical Products"
- Certificate of Traceability according EN 10204 3.1 of compounding and molding process with material analysis
- Test data available upon request
- REACH-Verordnung (EU) 1907/2006/EG is observed
- RoHS Directive 2011/65/EU is observed
- Certificate of Conformance with (EG) 596/2009

The image displays several overlapping documents related to diaphragm certification and compliance. Key documents include:

- Diaphragm Manufacturer Certificate:** A document with a header 'Diaphragm Hersteller' and 'Abnahmeprüfprotokoll / Inspektionsschein EN 10204 3.1'. It lists 'SED Flow Control GmbH' as the manufacturer and 'D-74098 Bad Rappenau' as the location. It includes a date '2018-08-01' and a signature line.
- Compound Manufacturer Certificate:** A document titled 'Ideen und Lösungen in der Gummiverarbeitung' and 'Compound Hersteller'. It includes a date '17.03.2018' and a signature line.
- Konformitätserklärung Membrane EPDM / PTFE:** Multiple copies of this document, which is a 'Certificate of conformity Diaphragm EPDM / PTFE'. It contains detailed technical data, material analysis results, and references to regulatory standards like 21CFR177.2600 and 21CFR177.1550.

## Diaphragm Traceability

All diaphragms are clearly identified and the material is batch traceable by a set of unique codes molded into the diaphragm.

Information provided on the order and shipping documents as well as on the packaging is described by the following. With the request of the Material Analysis Traceability Certificate DIN EN 10204 3.1 for manufacturing and formulation the additionally provided information is shown in bold type.

... on the order and shipping documents:

- SED article number, material code with description
- Customer article number on request
- **Batch number**
- **Shelf Life**

... on packaging in which the diaphragm is bagged and sealed in plastic:

- SED article number, material code with description
- Internal order series number
- Packaging quantity
- Customer article number on request
- **Batch number**
- **Shelf Life**

## Example markings MA8

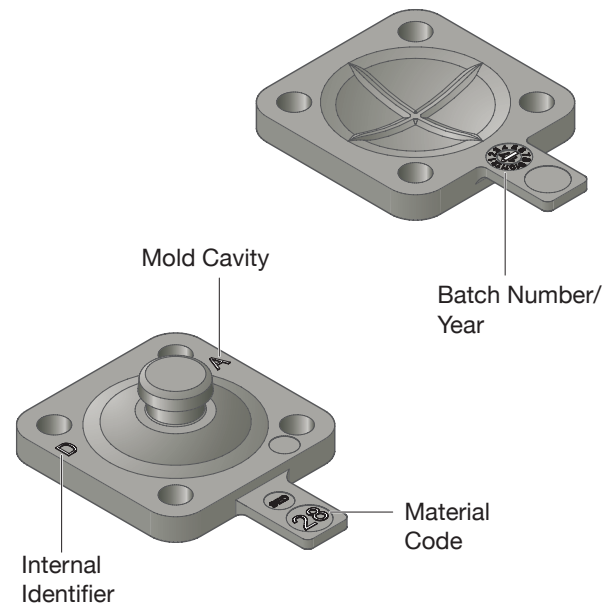

## Example markings MA ≥ 25

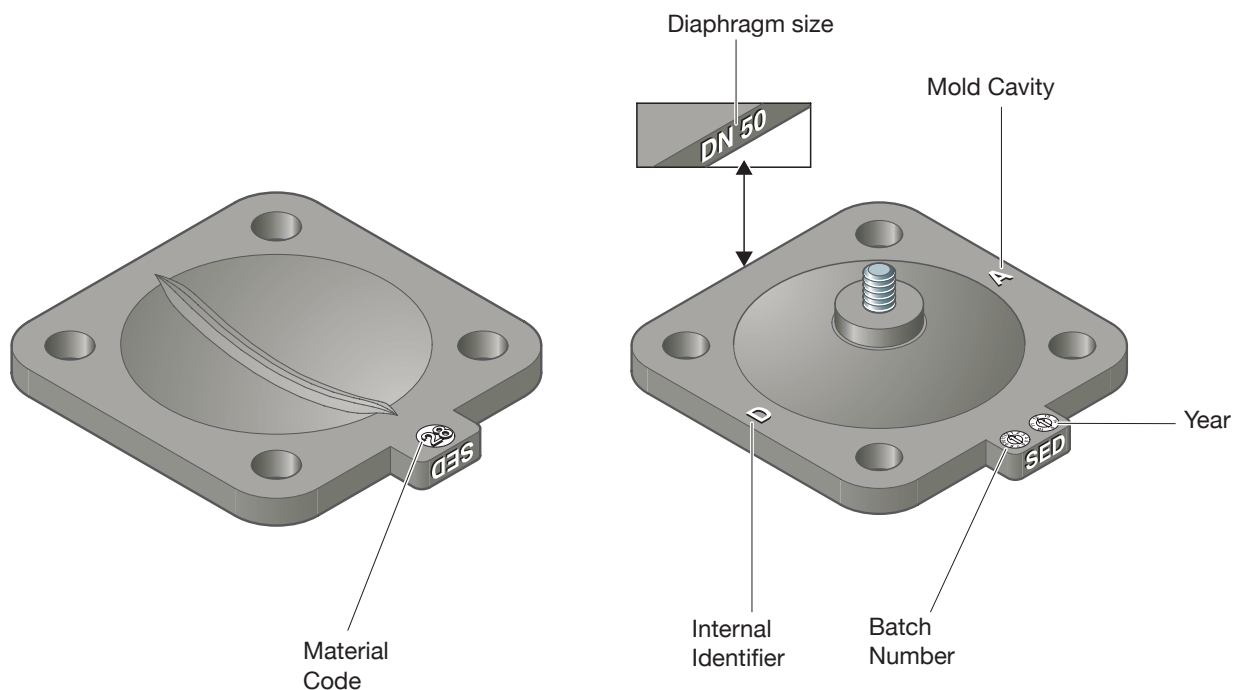

# Valve Bodies

The SED valve bodies as standard are manufactured of the material 1.4435 / S31603 ASME BPE Table MM-2.1-1 and according to EN 10204 inspection certificate 3.1/ Material Test Report (MTR). All valve bodies contain a stamped heat number that allows for traceability to the material properties and physical composition of the valve body. The interior body contour and contact surfaces are designed specifically to comply with the requirements of cGMP. Optimized cleanability and a cavity-free design eliminate entrapment areas and enhance diaphragm life. The SED valve bodies are produced out of raw forged, block material, or investment cast. Depending on the material and specification of the valve body, different manufacturing processes are used.

## Forged Bodies

The forged body begins from a solid piece of stainless steel ingot. In the forging process the shape of the material is changed through pressure between forging tools at elevated temperatures.



Through the forging procedure a high density and homogeneous structure of the material is obtained. This reduces the possibility of porosity or that any inclusions can emerge. After that, the forged body is mechanically machined according to the specification.

## Block Bodies

When producing bodies made of solid wrought block or bar stock material you obtain equal features to that of forgings. The individual raw valve bodies are cut from the block or bar stock and then are mechanically machined according to the specification. All the finished bodies can be supplied with a Delta Ferrite content of less than 0.5%.

## Tube End Standards

The following chart of international standards of pipe diameters identifies the different diameters comparing the example of a nominal diameter of DN 25.

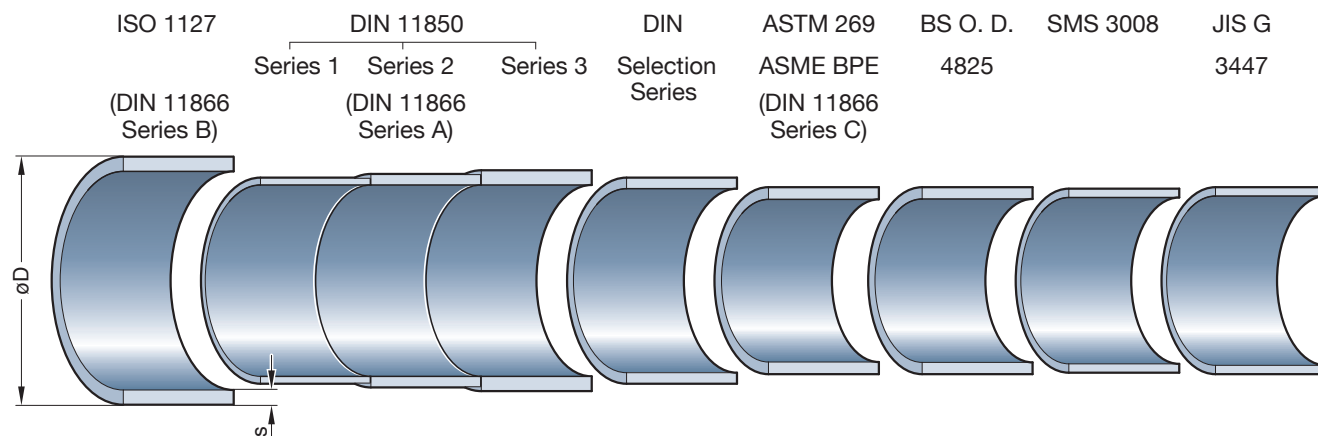

## Investment Cast

The investment cast bodies are produced in a pattern filled with wax containing the shape of the final valve body. By dipping the wax formed body in a ceramic material, the complete wax valve body is covered with ceramic. After melting the interior wax body, the ceramic shell is filled with molten stainless steel. The surrounding ceramic coating is removed and a very high dimensional accuracy and a clean and smooth surface results. In order to achieve a high quality investment cast products, SED patterns are designed and optimized for high quality castings. The bodies are checked according to detailed test specifications to ensure a reliable quality regarding the material structure and density.

| Component      | Tube Size             | Manufacturing Process |
|----------------|-----------------------|-----------------------|
| 2/2 way body   | 4 - 80 mm / 1/4 - 3"  | forged                |
|                | 100 - 150 mm / 4 - 6" | block material        |
|                | 4 - 100 mm / 1/4 - 4" | investment cast       |
| Multiport body | 4 - 150 mm / 1/4 - 6" | block material        |
| Tank valve     | 4 - 150 mm / 1/4 - 6" | block material        |

## Chemical Composition

Values listed in this Table are primary elements only and are not complete chemical compositions as listed in specific product type material specifications.

| Element         | 1.4435<br>Wt. % |
|-----------------|-----------------|
| Carbon, max.    | 0,030           |
| Manganese, max. | 2,00            |
| Chromium        | 17,00-19,00     |
| Nickel          | 12,50-15,00     |
| Molybdenum      | 2,50-3,00       |

According ASME BPE Table MM-2.1-1 alloy comparable with material S31603 and listed in previous versions of ASME BPE as 316L.

Sulfur content ASME BPE always within 0,005 to 0,017.

Other alloys are available on request, below is a list of materials machined from solid block:

- Super-Austenitic Stainless Steel
- Duplex Stainless Steel
- Nickel Alloys
- Titanium

# Butt Weld Tube Ends

SED offers tube end outside diameter and wall thickness dimensions in accordance to the several international standards. These standards and dimensions are listed in the below table.

In order to install a proper aseptic process piping system, it is important that the correct and consistent international tube end standards be followed throughout the aseptic process piping system. If the connecting tube ends are not identical and of the same diameter standard, there may

result a reduction or step in the process piping system or the ability of self draining ends is not guaranteed.

The most common standard connection is the butt-welding of the tube endings without any additional material. Examples of butt welding include automatic and orbital welding.

Besides the standard any customer-specified connection type is possible.

Some examples are displayed on the following pages.

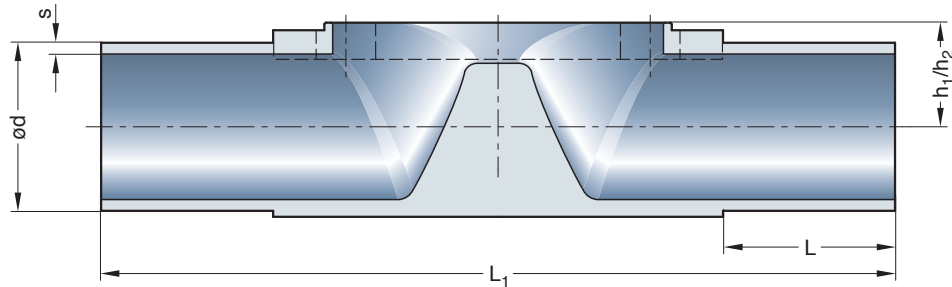

$h_1$  = Investment cast bodies  
 $h_2$  = forged bodies

| Butt weld Tube End Standard   | ISO 1127                 | DIN 11850                |                          | DIN                      | ASTM 269                 | BS O.D.                  | SMS                      | JIS G                    | JIS G                    |
|---|--------------------------|--------------------------|--------------------------|--------------------------|--------------------------|--------------------------|--------------------------|--------------------------|--------------------------|
|   | DIN 11866 Series B       | Series 1                 | Series 2                 | Selection Series         | ASME BPE                 | 4825                     | 3008                     | 3447                     | 3459                     |
| Code  | 40                       | 41                       | 42                       | 39                       | 45 <sup>1</sup>          | 94                       | 49                       | 97                       | 98 <sup>3</sup>          |
| DN NPS MA L <sub>(min)</sub> L <sub>1</sub> h <sub>1</sub> h <sub>2</sub> | $\varnothing d \times s$ | $\varnothing d \times s$ | $\varnothing d \times s$ | $\varnothing d \times s$ | $\varnothing d \times s$ | $\varnothing d \times s$ | $\varnothing d \times s$ | $\varnothing d \times s$ | $\varnothing d \times s$ |

| Valve Type Manually Operated 205 / 206 / 290 / 297 |     |   |    |    |   |   |                 |        |                     |        |                  |          |   |   |           |
|--|-----|---|----|----|---|---|-----------------|--------|---------------------|--------|------------------|----------|---|---|-----------|
| Valve Type Pneumatically Operated 190 / 207 / 217  |     |   |    |    |   |   |                 |        |                     |        |                  |          |   |   |           |
| 4  | -   | 8 | 20 | 72 | 9 | 9 | -               | -      | -                   | 6x1,0  | -                | -        | - | - | -         |
| 6  | -   | 8 | 20 | 72 | 9 | 9 | -               | -      | 8x1,0 <sup>2</sup>  | 8x1,0  | -                | -        | - | - | 10,5x1,2  |
| 8  | 1/4 | 8 | 20 | 72 | 9 | 9 | <b>13,5x1,6</b> | -      | 10x1,0 <sup>2</sup> | 10x1,0 | 6,35x0,89        | -        | - | - | 13,8x1,65 |
| 10   | 3/8 | 8 | 20 | 72 | 9 | 9 | -               | 12x1,0 | <b>13x1,5</b>       | -      | 9,53x0,89        | -        | - | - | -         |
| 15   | 1/2 | 8 | 20 | 72 | 9 | 9 | -               | -      | -                   | -      | <b>12,7x1,65</b> | 12,7x1,2 | - | - | -         |

| Valve Type Manually Operated 289 / 295 / 397                  |     |    |    |     |    |    |                 |        |               |        |                        |           |   |   |           |
|---|-----|----|----|-----|----|----|-----------------|--------|---------------|--------|------------------------|-----------|---|---|-----------|
| Valve Type Pneumatically Operated 188 / 195 / 317 / 392 / 394 |     |    |    |     |    |    |                 |        |               |        |                        |           |   |   |           |
| 8   | -   | 10 | 25 | 108 | 12 | 12 | 13,5x1,6        | -      | -             | -      | -                      | -         | - | - | -         |
| 10  | 3/8 | 10 | 25 | 108 | 12 | 12 | <b>17,2x1,6</b> | 12x1,0 | 13x1,5        | -      | 9,53x0,89 <sup>3</sup> | -         | - | - | 17,3x1,65 |
| 15  | 1/2 | 10 | 25 | 108 | 12 | 12 | <b>21,3x1,6</b> | 18x1,0 | <b>19x1,5</b> | 18x1,5 | 12,7x1,65              | 12,7x1,2  | - | - | 21,7x2,1  |
| 20  | 3/4 | 10 | 25 | 108 | 12 | 12 | -               | -      | 23x1,5        | 22x1,5 | <b>19,05x1,65</b>      | 19,05x1,2 | - | - | -         |

| Valve Type Manually Operated 905 / 907 / 982 / 985 / 995 / 997            |       |     |    |     |     |    |                  |        |                |        |                         |   |           |                       |          |
|---|-------|-----|----|-----|-----|----|------------------|--------|----------------|--------|-------------------------|---|-----------|-----------------------|----------|
| Valve Type Pneumatically Operated 385 / 395 / 402 / 407 / 417 / 495 / 592 |       |     |    |     |     |    |                  |        |                |        |                         |   |           |                       |          |
| 15  | -     | 25  | 25 | 120 | 13  | 16 | 21,3x1,6         | 18x1,0 | 19x1,5         | -      | 12,7x1,65 <sup>3</sup>  | - | -         | -                     | 21,7x2,1 |
| 20  | 3/4   | 25  | 25 | 120 | 16  | 16 | <b>26,9x1,6</b>  | 22x1,0 | <b>23x1,5</b>  | -      | 19,05x1,65              | - | -         | -                     | 27,2x2,1 |
| 25  | 1     | 25  | 25 | 120 | 19  | 19 | <b>33,7x2,0</b>  | 28x1,0 | <b>29x1,5</b>  | 28x1,5 | <b>25,4x1,65</b>        | - | 25,0x1,2  | 25,4x1,2              | -        |
| 32  | 1 1/4 | 40  | 25 | 153 | 24  | 26 | <b>42,4x2,0</b>  | 34x1,0 | <b>35x1,5</b>  | -      | 31,75x1,65 <sup>3</sup> | - | 33,7x1,2  | 31,8x1,2 <sup>3</sup> | -        |
| 40  | 1 1/2 | 40  | 25 | 153 | 24  | 26 | <b>48,3x2,0</b>  | 40x1,0 | <b>41x1,5</b>  | -      | <b>38,1x1,65</b>        | - | 38,0x1,2  | 38,1x1,2              | -        |
| 50  | 2     | 50  | 30 | 173 | 32  | 32 | <b>60,3x2,0</b>  | 52x1,0 | <b>53x1,5</b>  | -      | <b>50,8x1,65</b>        | - | 51,0x1,2  | 50,8x1,5              | -        |
| 65  | 2 1/2 | 50  | 30 | 173 | 32  | 32 | -                | -      | -              | -      | <b>63,5x1,65</b>        | - | 63,5x1,6  | 63,5x2,0 <sup>3</sup> | -        |
| 65  | 2 1/2 | 80  | 25 | 216 | 47  | 47 | <b>76,1x2,0</b>  | -      | <b>70x2,0</b>  | -      | <b>63,5x1,65</b>        | - | 63,5x1,6  | 63,5x2,0 <sup>3</sup> | -        |
| 80  | 3     | 80  | 30 | 254 | 47  | 47 | <b>88,9x2,3</b>  | -      | <b>85x2,0</b>  | -      | <b>76,2x1,65</b>        | - | 76,1x1,6  | 76,3x2,0              | -        |
| 100   | 4     | 100 | 30 | 305 | 61  | 58 | <b>114,3x2,3</b> | -      | <b>104x2,0</b> | -      | <b>101,6x2,11</b>       | - | 101,6x2,0 | 101,6x2,1             | -        |
| 125   | 5     | 150 | 30 | 450 | 100 | 90 | <b>139,7x2,6</b> | -      | <b>129x2,0</b> | -      | -                       | - | -         | -                     | -        |
| 150   | 6     | 150 | 30 | 450 | 100 | 96 | <b>168,3x2,6</b> | -      | <b>154x2,0</b> | -      | <b>152,4x2,77</b>       | - | -         | -                     | -        |

Dimensions in mm; MA = Diaphragm size / Upon request, other tube end standards are available / Preferred standards bold

<sup>1</sup> ASTM 269 ASME BPE tube diameter (Code 45) in forged version optional also available in tube end length according ASME BPE (Code 95); Tube Size 1/4" to 2 1/2" L = 1,5" (38,1 mm); Tube Size 3" L = 1,75" (44,45 mm); Tube Size 4" L = 2" (50,8 mm); Tube Size 6" L = 2,5" (63,5 mm)

<sup>2</sup> DIN 11866 only

<sup>3</sup> Available only in forged design

## Clamps

The clamp connection is the most popular connection for easy assembly and breakdown of process lines and valves. The clamp end connection is designed for a face-to-face joint that is leak proof and free of crevices.

The clamp end has a machined beveled seat and is used with specifically formed sealing gaskets made of EPDM or PTFE.

The gasket is inserted between the opposing clamp ends and is compressed tight with a wing nut quick disconnect clamp.

In general, the valve clamp ends are welded to the valve butt weld ends and polished according to the specified interior valve body surface finish.

The welded clamp ends are 100% visually inspected and compression tested. The clamp connections are available for all current pipe standard diameters.

If the connecting clamp ends are not identical and of the same diameter standard, there may result a reduction or step in the process piping system or the ability of self draining ends is not guaranteed.

If assembled correctly, the clamp end process system offers a smooth, crevice-free, self-aligning joint that reduce the hazards of contamination but minimize turbulence and pressure drop through the system.

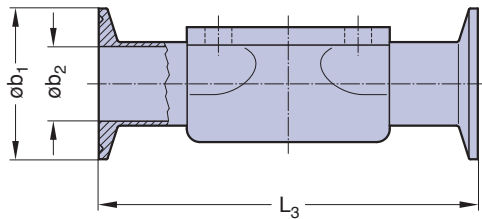

Dimensions Inch

| Clamp End Ident.<br>Tube End Ident. |       |     | ASME BPE<br>ASME BPE |                |                | ASME BPE<br>ASME BPE |                |                |
|-------------------------------------|-------|-----|----------------------|----------------|----------------|----------------------|----------------|----------------|
| Code FtF                            |       |     | 645                  |                |                | 545                  |                |                |
| Standard FtF                        |       |     | DIN EN 558-1         |                |                | ASME BPE DT-V-1      |                |                |
| DN                                  | NPS   | MA  | L <sub>3</sub>       | b <sub>2</sub> | b <sub>1</sub> | L <sub>3</sub>       | b <sub>2</sub> | b <sub>1</sub> |
| 8                                   | 1/4   | 8   | -                    | -              | -              | 2,5                  | 0,18           | 1              |
| 10                                  | 3/8   | 8   | -                    | -              | -              | 2,5                  | 0,31           | 1              |
| 15                                  | 1/2   | 8   | 2,5                  | 0,37           | 1              | 2,5                  | 0,37           | 1              |
| 10                                  | 3/8   | 10  | -                    | -              | -              | -                    | -              | -              |
| 15                                  | 1/2   | 10  | 4,25                 | 0,37           | 1              | 3,5                  | 0,37           | 1              |
| 20                                  | 3/4   | 10  | 4,60                 | 0,62           | 1              | 4,0                  | 0,62           | 1              |
| 15                                  | 1/2   | 25  | 4,25                 | 0,37           | 1              | 4,0                  | 0,37           | 1              |
| 20                                  | 3/4   | 25  | 4,60                 | 0,62           | 1              | 4,0                  | 0,62           | 1              |
| 25                                  | 1     | 25  | 5,00                 | 0,87           | 2              | 4,5                  | 0,87           | 2              |
| 32                                  | 1 1/4 | 40  | -                    | -              | -              | -                    | -              | -              |
| 40                                  | 1 1/2 | 40  | 6,25                 | 1,37           | 2              | 5,5                  | 1,37           | 2              |
| 50                                  | 2     | 50  | 7,50                 | 1,87           | 2,5            | 6,25                 | 1,87           | 2,5            |
| 65                                  | 2 1/2 | 80  | 8,50                 | 2,37           | 3              | *8,75                | 2,37           | 3              |
| 80                                  | 3     | 80  | 10,00                | 2,87           | 3,5            | 8,75                 | 2,87           | 3,5            |
| 100                                 | 4     | 100 | 12,00                | 3,83           | 4,5            | 11,5                 | 3,83           | 4,5            |

Dimensions mm

| Clamp End Ident.<br>Tube End Ident. |       |     | Similar ISO 2852<br>ISO 1127 |                |                | DIN 32676<br>DIN 11850 |                |                | ASME BPE<br>ASME BPE |                |                | ASME BPE<br>ASME BPE |                |                | SMS 3017<br>SMS 3008 |                |                |
|-------------------------------------|-------|-----|------------------------------|----------------|----------------|------------------------|----------------|----------------|----------------------|----------------|----------------|----------------------|----------------|----------------|----------------------|----------------|----------------|
| Code Face to face (FtF)             |       |     | 640                          |                |                | 641/642                |                |                | 645                  |                |                | 545                  |                |                | 649                  |                |                |
| Standard FtF                        |       |     | DIN EN 558-1                 |                |                | DIN EN 558-1           |                |                | DIN EN 558-1         |                |                | ASME BPE DT-4.4.1-1  |                |                | DIN EN 558-1         |                |                |
| DN                                  | NPS   | MA  | L <sub>3</sub>               | b <sub>2</sub> | b <sub>1</sub> | L <sub>3</sub>         | b <sub>2</sub> | b <sub>1</sub> | L <sub>3</sub>       | b <sub>2</sub> | b <sub>1</sub> | L <sub>3</sub>       | b <sub>2</sub> | b <sub>1</sub> | L <sub>3</sub>       | b <sub>2</sub> | b <sub>1</sub> |
| 8                                   | 1/4   | 8   | *63,5                        | 10,3           | 25,0           | -                      | -              | -              | -                    | -              | -              | 63,5                 | 4,57           | 25,0           | -                    | -              | -              |
| 10                                  | 3/8   | 8   | -                            | -              | -              | *63,5                  | 10,0           | 34,0           | -                    | -              | -              | 63,5                 | 7,75           | 25,0           | -                    | -              | -              |
| 15                                  | 1/2   | 8   | -                            | -              | -              | -                      | -              | -              | *63,5                | 9,40           | 25,0           | 63,5                 | 9,40           | 25,0           | -                    | -              | -              |
| 10                                  | 3/8   | 10  | 108,0                        | 14,0           | 25,0           | 108,0                  | 10,0           | 34,0           | -                    | -              | -              | -                    | -              | -              | -                    | -              | -              |
| 15                                  | 1/2   | 10  | 108,0                        | 18,1           | 50,5           | 108,0                  | 16,0           | 34,0           | 108,0                | 9,40           | 25,0           | 88,9                 | 9,40           | 25,0           | -                    | -              | -              |
| 20                                  | 3/4   | 10  | -                            | -              | -              | 117,0                  | 20,0           | 34,0           | 117,0                | 15,75          | 25,0           | 101,6                | 15,75          | 25,0           | -                    | -              | -              |
| 15                                  | 1/2   | 25  | 108,0                        | 18,1           | 50,5           | 108,0                  | 16,0           | 34,0           | 108,0                | 9,40           | 25,0           | 101,6                | 9,40           | 25,0           | -                    | -              | -              |
| 20                                  | 3/4   | 25  | 117,0                        | 23,7           | 50,5           | 117,0                  | 20,0           | 34,0           | 117,0                | 15,75          | 25,0           | 101,6                | 15,75          | 25,0           | -                    | -              | -              |
| 25                                  | 1     | 25  | 127,0                        | 29,7           | 50,5           | 127,0                  | 26,0           | 50,5           | 127,0                | 22,10          | 50,5           | 114,3                | 22,10          | 50,5           | 127,0                | 22,6           | 50,5           |
| 32                                  | 1 1/4 | 40  | 146,0                        | 38,4           | 50,5           | 146,0                  | 32,0           | 50,5           | 146,0                | 28,45          | 50,5           | 139,7                | 28,45          | 50,5           | 146,0                | 31,3           | 50,5           |
| 40                                  | 1 1/2 | 40  | 159,0                        | 44,3           | 64,0           | 159,0                  | 38,0           | 50,5           | 159,0                | 34,80          | 50,5           | 139,7                | 34,80          | 50,5           | 159,0                | 35,6           | 50,5           |
| 50                                  | 2     | 50  | 190,0                        | 56,3           | 77,5           | 190,0                  | 50,0           | 64,0           | 190,0                | 47,50          | 64,0           | 158,8                | 47,50          | 64,0           | 190,0                | 48,6           | 64,0           |
| 65                                  | 2 1/2 | 80  | 216,0                        | 72,1           | 91,0           | 216,0                  | 66,0           | 91,0           | 216,0                | 60,20          | 77,5           | *222,3               | 60,20          | 77,5           | 216,0                | 60,3           | 77,5           |
| 80                                  | 3     | 80  | 254,0                        | 84,3           | 106,0          | 254,0                  | 81,0           | 106,0          | 254,0                | 72,90          | 91,0           | 222,3                | 72,90          | 91,0           | 254,0                | 72,9           | 91,0           |
| 100                                 | 4     | 100 | 305,0                        | 109,7          | 130,0          | 305,0                  | 100,0          | 119,0          | 305,0                | 97,38          | 119,0          | 292,1                | 97,38          | 119,0          | 305,0                | 97,6           | 119,0          |

\*Length differing from standard; other lengths on request

# Aseptic Connections

## Aseptic Threads

Threaded spigot, liner and the interjacent seal are compressed with a spigot nut.

- Milk-threaded ends DIN 11851 with form sealing
- Aseptic connection according to DIN 11864-1 A with partly open o-ring for optimized cleaning features and a reduced dead leg. The threaded spigot, the liner and the interjacent o-ring are compressed against a metallic block with a spigot nut.

The connections are available for the current pipe standards within the aseptic application.

The threaded spigot and liner are welded with the pipe ends and the weld seam is polished according to the specified interior valve surface finish.

| L in mm |       |     | DIN 11851      |              | DIN 11864-1-A  |              |
|---------|-------|-----|----------------|--------------|----------------|--------------|
| DN      | NPS   | MA  | Code 8..       |              | Code 4..       |              |
|         |       |     | L <sub>2</sub> | G            | L <sub>2</sub> | G            |
| 4       | -     | 8   | -              | -            | -              | -            |
| 6       | -     | 8   | -              | -            | -              | -            |
| 8       | 1/4   | 8   | -              | -            | -              | -            |
| 10      | 3/8   | 8   | 92             | Rd 28 x 1/8  | 92             | Rd 28 x 1/8  |
| 15      | 1/2   | 8   | -              | -            | -              | -            |
| 8       | 1/4   | 10  | -              | -            | -              | -            |
| 10      | 3/8   | 10  | 118            | Rd 28 x 1/8  | 118            | Rd 28 x 1/8  |
| 15      | 1/2   | 10  | 118            | Rd 34 x 1/8  | 118            | Rd 34 x 1/8  |
| 20      | 3/4   | 10  | -              | -            | -              | -            |
| 15      | 1/2   | 25  | 118            | Rd 34 x 1/8  | 120            | Rd 34 x 1/8  |
| 20      | 3/4   | 25  | 118            | Rd 44 x 1/6  | 144            | Rd 44 x 1/6  |
| 25      | 1     | 25  | 128            | Rd 52 x 1/6  | 164            | Rd 52 x 1/6  |
| 32      | 1 1/4 | 40  | 147            | Rd 58 x 1/6  | 192            | Rd 58 x 1/6  |
| 40      | 1 1/2 | 40  | 160            | Rd 65 x 1/6  | 214            | Rd 65 x 1/6  |
| 50      | 2     | 50  | 191            | Rd 78 x 1/6  | 244            | Rd 78 x 1/6  |
| 65      | 2 1/2 | 80  | 246            | Rd 95 x 1/6  | 314            | Rd 95 x 1/6  |
| 80      | 3     | 80  | 256            | Rd 110 x 1/4 | 342            | Rd 110 x 1/4 |
| 100     | 4     | 100 | -              | -            | -              | Rd 130 x 1/4 |

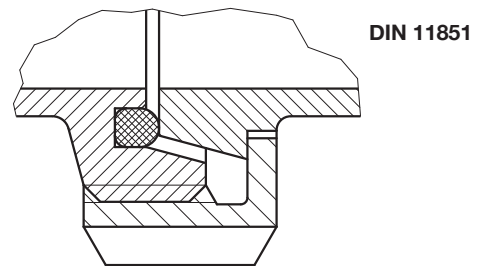
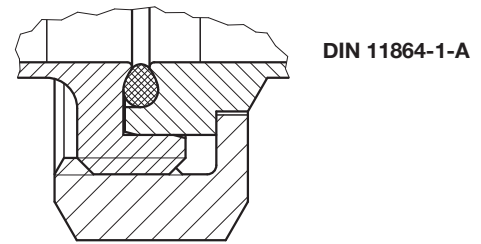
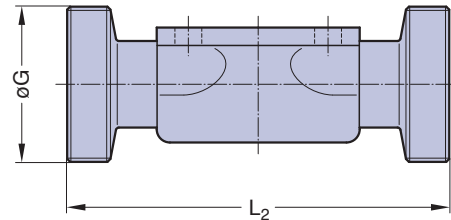

## Aseptic Flanges

Aseptic flanges according to DIN 11864-2 Form A are connections with a partly open o-ring for optimized cleaning features and a reduced dead leg. The round flange and the groove flange are welded with the pipe ends and the weld seam is polished according to the specified interior valve body surface finish.

The connections are available for the current pipe standards within the aseptic application.

The round flange and the groove flange are welded orbital with the pipe endings and the weld seam is polished mechanically according to the valve body.

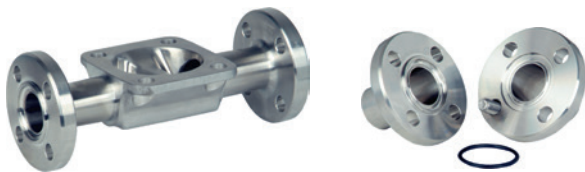

|     |       |     | DIN 11864-2-A  |     |     |      |
|-----|-------|-----|----------------|-----|-----|------|
| DN  | NPS   | MA  | Code 3.. (mm)  |     |     |      |
|     |       |     | L <sub>4</sub> | C   | k   | e    |
| 10  | 3/8   | 10  | 130            | 54  | 37  | ø 9  |
| 15  | 1/2   | 25  | 130            | 59  | 42  | ø 9  |
| 20  | 3/4   | 25  | 150            | 64  | 47  | ø 9  |
| 25  | 1     | 25  | 160            | 70  | 53  | ø 9  |
| 32  | 1 1/4 | 40  | 180            | 76  | 59  | ø 9  |
| 40  | 1 1/2 | 40  | 200            | 82  | 65  | ø 9  |
| 50  | 2     | 50  | 230            | 94  | 77  | ø 9  |
| 65  | 2 1/2 | 80  | 290            | 113 | 95  | ø 9  |
| 80  | 3     | 80  | 310            | 133 | 112 | ø 11 |
| 100 | 4     | 100 | 350            | 159 | 137 | ø 11 |

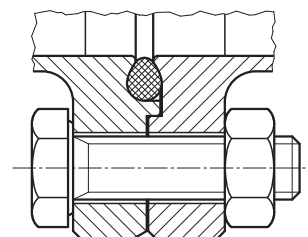
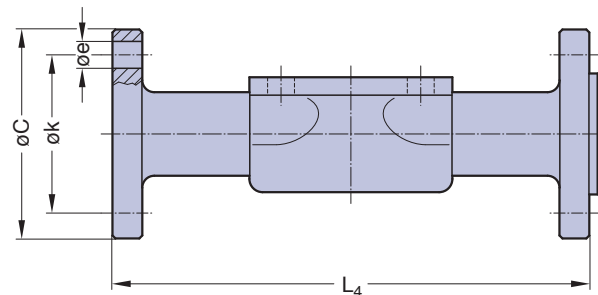

## Aseptic Clamps

Aseptic connection according to DIN 11864-3 with partly open o-ring for optimized cleaning features and a reduced dead leg. The aseptic clamp with groove, the aseptic clamp with collar and the interjacent o-ring are compressed against a metallic block with a closure clamp.

The connections are available for the current pipe standards within the aseptic application. The aseptic clamp with groove and the aseptic clamp with collar are welded with the pipe ends and the weld seam is polished according to the specified interior valve surface finish.





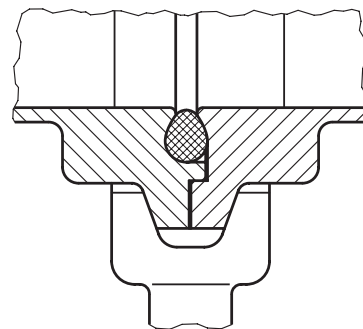
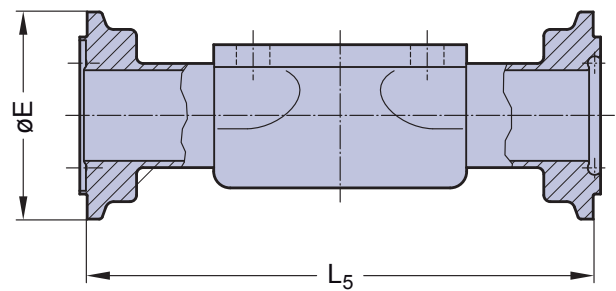

| DN  | NPS   | MA         | DIN 11864-3    |     |
|-----|-------|------------|----------------|-----|
|     |       |            | L <sub>5</sub> | E   |
| 10  | 3/8   | <b>8</b>   | 63,5           | 34  |
| 10  | 3/8   | <b>10</b>  | 108            | 34  |
| 15  | 1/2   | <b>10</b>  | 108            | 34  |
| 20  | 3/4   | <b>10</b>  | 117            | 42  |
| 15  | 1/2   | <b>25</b>  | 108            | 34  |
| 20  | 3/4   | <b>25</b>  | 117            | 42  |
| 25  | 1     | <b>25</b>  | 127            | 42  |
| 32  | 1 1/4 | <b>40</b>  | 146            | 42  |
| 40  | 1 1/2 | <b>40</b>  | 159            | 54  |
| 50  | 2     | <b>50</b>  | 190            | 62  |
| 65  | 2 1/2 | <b>80</b>  | 216            | 78  |
| 80  | 3     | <b>80</b>  | 254            | 93  |
| 100 | 4     | <b>100</b> | 305            | 115 |











|          |   |  |
|----------|---|--|
| <b>1</b> | <b>Introduction</b><br>Overview   | Page<br>4 - 11   |
| <b>2</b> | <b>Media Contacted Components</b><br>Diaphragms<br>Valve Bodies (fold out page)<br>Butt Weld Tube Ends (fold out page)<br><b>Aseptic Connections</b>  | 14 - 19<br>20<br>21<br><b>22 - 24</b>  |
| <b>3</b> | <b>Aseptic Diaphragm Valves</b><br><b>Overview Diaphragm Aseptic Valves</b><br>Why Aseptic Diaphragm Valve?<br>Self Draining - Two-Way Valve<br>Innovative Design<br><b>Aseptic Diaphragm Valves</b><br>STERIPUR Series<br>KMA Series<br>KMD Series<br><b>Ordering Key and Ordering Example</b>   | 26, 27<br>28<br>29<br>30 - 33<br>34 - 46<br>48 - 58<br>60 - 65<br>66 - 68        |
| <b>4</b> | <b>Aseptic Diaphragm Valve Configurations</b><br><b>D-Rule</b><br><b>Welded Valve Configurations</b><br><b>Multiport Valves</b><br>Why Multiport Valves?<br>Main line open, Loop Valves (e.g. T-Valve)<br>All lines and valve ports able to close<br>The way of customized multiport valve designs<br>Specification Multiport Valves<br><b>Tank Valves</b><br><b>Process Solutions</b><br>Sterile Sampling Unit<br>Purified Steam Sampling Unit | 72<br>73 - 75<br>76<br>77 - 81<br>82 - 87<br>88<br>89<br>90 - 93<br>94<br>95     |
| <b>5</b> | <b>Angle Seat Valves</b><br>Description and Features<br>Technical Data<br>Regulating cone<br>2/2-Way Angle Seat Valves<br>Valve Body Dimensions<br>Ordering Key and Ordering Example  | 98, 99<br>100 - 101<br>102 - 105<br>106 - 114<br>115 - 117<br>118, 119           |
| <b>6</b> | <b>Ball Valves</b><br>Manual Ball Valve Description and Features<br>Pneumatically Ball Valve Description and Features<br>Technical Data<br>Ordering Key   | 123<br>124<br>125 - 128<br>129   |
| <b>7</b> | <b>System Components and Process Automation</b><br><b>Overview</b><br>Manual Adjustment - Optical Indication<br>Electrical Switch Boxes - Pilot Control<br><b>Detailed Information</b><br>3/2 Way Plastic Pilot Valve<br>Control Head Switch 024.63. - 024.89.<br>Contact-Free Limit Switch 024.50<br><b>Process Automation, Electropneumatic Positioners</b><br><b>Overview Product Range</b><br><b>Glossary</b>                               | 132<br>133<br>134<br>135, 136<br>137<br>138, 139<br>140 - 143<br>144<br>145, 146 |

# Overview Aseptic Valves

| Series                                       | Description   | Specification   |   |   |   |
|--|---|---|---|---|---|
| <b>Steripur</b><br>Stainless Steel Actuation | Control function available                                  | Manual  |   |   |   |
|  | <b>Diaphragm size</b>                                       | <b>MA 8</b>   | <b>MA 10</b>  | <b>MA 25 - 50</b>   | <b>MA 80 - 100</b>  |
|  | Diameter in mm (inch)                                       | 4 - 15 (1/4 - 1/2)  | 8 - 20 (3/8 - 3/4)  | 15 - 50 (3/4 - 2 1/2)   | 65 - 100 (2 1/2 - 4)  |
|  | Type  | <b>206</b>  | <b>397</b>  | <b>907</b>  | <b>997</b>  |
|  | Image   |  |  |  |  |
|  | Max. working pressure with<br>- diaphragm EPDM in bar (psi) | 10 (150)  | 10 (150)  | 10 (150)  | 10 (150)  |
|  | - diaphragm PTFE in bar (psi)                               | 10 (150)  | 10 (150)  | 10 (150)  | 8 (115)   |
|  | Max. working temperature °C (°F) <sup>2</sup>               | 160 (320)   |   |   |   |
|  | Details see page  | <b>34</b>   | <b>35</b>   | <b>36</b>   | <b>37</b>   |

|   |   |   |   |   |   |
|---|---|---|---|---|---|
| <b>KMA</b><br>Actuation with Stainless Steel Bonnet | Control function available                                  | Manual  |   |   |   |
|   | <b>Diaphragm size</b>                                       | <b>MA 8</b>   | <b>MA 10</b>  | <b>MA 25 - 50</b>   | <b>MA 80 - 100</b>  |
|   | Diameter in mm (inch)                                       | 4 - 15 (1/4 - 1/2)  | 8 - 20 (3/8 - 3/4)  | 15 - 50 (3/4 - 2 1/2)   | 65 - 100 (2 1/2 - 4)  |
|   | Type  | <b>205</b>  | <b>295</b>  | <b>905</b>  | <b>995</b>  |
|   | Image   |  |  |  |  |
|   | Max. working pressure with<br>- diaphragm EPDM in bar (psi) | 10 (150)  | 10 (150)  | 10 (150)  | 10 (150)  |
|   | - diaphragm PTFE in bar (psi)                               | 10 (150)  | 10 (150)  | 10 (150)  | 8 (115)   |
|   | Max. working temperature °C (°F) <sup>2</sup>               | 160 (320)   |   |   |   |
|   | Details see page  | <b>48, 49</b>   | <b>50, 51</b>   | <b>52, 53</b>   | <b>54</b>   |

|   |   |   |   |   |
|---|---|---|---|---|
| <b>KMD</b><br>Plastic Actuation directly mounted        | Control function available                                  | Manual  |   |   |
|   | <b>Diaphragm size</b>                                       | <b>MA 10</b>  | <b>MA 25 - 50</b>   | <b>MA 80 - 100</b>  |
|   | Diameter in mm (inch)                                       | 8 - 20 (3/8 - 3/4)  | 15 - 50 (3/4 - 2 1/2)   | 65 - 100 (2 1/2 - 4)  |
|   | Type  | <b>289</b>  | <b>982</b>  | <b>985</b>  |
|   | Image   |  |  |  |
|   | Max. working pressure with<br>- diaphragm EPDM in bar (psi) | 6 (87)  | 10 (150)  | 10 (150)  |
|   | - diaphragm PTFE in bar (psi)                               | 6 (87)  | 10 (150)  | 8 (115)   |
|   | Max. working temperature °C (°F), design HS <sup>2</sup>    | 150 (300)   | NA  | NA  |
| Max. working temperature °C (°F), design S <sup>2</sup> | 80 (176)  |   |   |   |
| Details see page  | <b>60</b>   | <b>61</b>   | <b>62</b>   |   |





<sup>2</sup> dependent on application





MA = Diaphragm size



Differentiations between the series see table page 30

# Overview Aseptic Valves



| Specification   |   |   |  |   | Series                                |
|---|---|---|--|---|---------------------------------------|
| Pneumatically operated  |   |   |  |   | Steripur<br>Stainless Steel Actuation |
| NO, DA  | NC  | NC, NO, DA  |  |   |                                       |
| <b>MA 8</b>   |   | <b>MA 10</b>  | <b>MA 25 - 50</b>  | <b>MA 80   100</b>  |                                       |
| 4 - 15 (1/4 - 1/2)  |   | 8 - 20 (3/8 - 3/4)  | 15 - 50 (3/4 - 2 1/2)  | 65 - 100 (2 1/2 - 4)  |                                       |
| <b>217.25</b>   | <b>217.30</b>   | <b>317<sup>1</sup></b>  | <b>417<sup>1</sup></b>   | <b>407</b>  |                                       |
|  |  |  |  |  |                                       |
| 4,5 (65)  | 8 (115)   | 8 (115)   | 10 (150)   | 7 (100)   6 (87)  |                                       |
| 4 (60)  | 7 (100)   | 7 (100)   | 8 (115)  | 6 (87)   5 (72)   |                                       |
| 160 (320)   |   |   |  |   |                                       |
| <b>38, 39</b>   |   | <b>40</b>   | <b>42, 43</b>  | <b>41</b>   |                                       |

|   |   |  |   |  |
|---|---|--|---|--|
| Pneumatically operated  |   |  |   | KMA<br>Actuation with Stainless Steel Bonnet |
| NC, NO, DA  |   |  |   |  |
| <b>MA 8</b>   | <b>MA 10</b>  | <b>MA 25 - 50</b>  | <b>MA 25 - 50   80   100</b>  |  |
| 4 - 15 (1/4 - 1/2)  | 8 - 20 (3/8 - 3/4)  | 15 - 50 (3/4 - 2 1/2)  | 15 - 100 (3/4 - 4)  |  |
| <b>190</b>  | <b>195</b>  | <b>395</b>   | <b>495</b>  |  |
|  |  |  |  |  |
| 8 (115)   | 8 (115)   | 10 (150)   | 10 (150)   7 (100)   6 (87)   |  |
| 7 (100)   | 7 (100)   | 8 (115)  | 8 (115)   6 (87)   5 (72)   |  |
| 160 (320)   |   |  |   |  |
| <b>55</b>   | <b>56</b>   | <b>57</b>  | <b>58</b>   |  |

|   |  |   |   |
|---|--|---|---|
| Pneumatically operated  |  |   | KMD<br>Plastic Actuation directly mounted |
| NC, NO, DA  |  |   |   |
| <b>MA 10</b>  | <b>MA 25 - 50</b>  | <b>MA 25 - 50   80</b>  |   |
| 8 - 20 (3/8 - 3/4)  | 15 - 50 (3/4 - 2 1/2)  | 15 - 100 (3/4 - 4)  |   |
| <b>188</b>  | <b>402</b>   | <b>385</b>  |   |
|  |  |  |   |
| 8 (115)   | 10 (150)   | 10 (150)   7 (100)  |   |
| 7 (100)   | 8 (115)  | 8 (115)   6 (87)  |   |
| 150 (300)   | 150 (300)  | NA  |   |
| 80 (176)  | NA   | 80 (176)  |   |
| <b>63</b>   | <b>64</b>  | <b>65</b>   |   |

<sup>1</sup> available also with two-stage actuator, see page 44 to 46

# Why Aseptic Diaphragm Valve?

The standard valve assembly consists of three components: the valve body, the diaphragm and the actuation. Due to its unique characteristics, the diaphragm valve has prevailed for aseptic processes. Demanding requirements for higher quality in process applications is proceeded by our developing innovative and advanced solutions. SED's priority is to commit the resources needed and achieve high quality standards based on continuous developments beneficial for the customer's application. These developments provide the latest applied knowledge and standards, the requirement of compliances, and recommendations of the admission organizations.

## General and SED Specific Criteria:

- Positive Closure**  
 The resilient diaphragm bead in contact with the metal weir assures positive closure.
- Ideal for CIP and SIP**  
 Clean-in-place and Steam-in-place operations may be performed in-line without valve disassembly or operation.
- In-Line Maintenance**  
 The top entry design allows for in-line maintenance.
- Bonnet Isolation**  
 The diaphragm isolates the working parts of the valve from the process media.
- Streamline Fluid Passage**  
 A smooth contoured body, streamlined flow path and high quality interior surface prevents the accumulation of process fluids or contaminants.
- Minimal Contact Surfaces**  
 The process contact surfaces (body and diaphragm) are minimal, enhancing the ease of cleaning and sterilization.
- One Centerline for Inlet and Outlet**  
 One centerline for inlet and outlet simplifies installation and plant design work.
- Modular Construction System**  
 Modular valve construction system reduces complexity and maintenance expense.

## Working Pressure from One and Both Sides for Pneumatic Operation (see illustration on the right)

The reference to the maximum possible working pressure in this catalogue is only valid for uni-directional media with a pressure drop ( $\Delta p = 100\%$ ) independent from the flow direction. Uni-directional working pressure corresponds to most applications.

If the media pressure is simultaneously the same on both sides ( $\Delta p = 0\%$ ) i. e. due to a certain applications of the valve in a loop installation, please ask a factory representative for the maximum possible working pressure or to specify for the correct layout of the valve.  
 If the sum of the two pressures does not exceed the maximum possible working pressure from one side, the valve can be applied for that application.

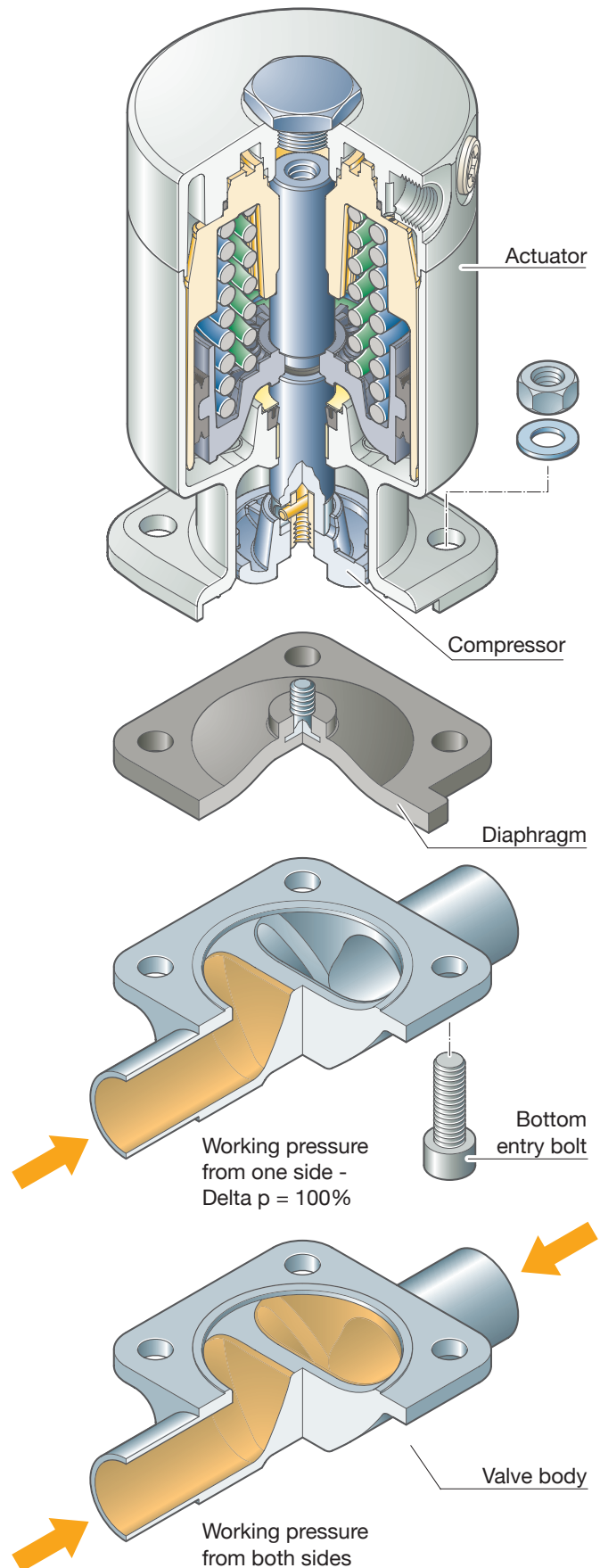

# Self Draining - Two-Way Valve

One of the most important criteria of all valves applied in aseptic processes is the drainability. This feature has contributed substantially why the diaphragm valve has prevailed as the valve of choice for aseptic process applications.

To achieve optimum self draining for horizontal installed valves, the following criteria are relevant:

- Correct design and inner contours of the two-way body
- Internal surface quality of the two-way body
- Cavity free valve assembly
- Self draining installation position
- End connections
- Slope of the installed two-way body
- Consistency of the media

It is essential that the valve be installed at the specific angle allowing the media to fully drain in the open position. See the illustration below and the corresponding table showing the specific angle depended on tube size, standard, as well as the material selection of the two-way body. For optimum drainability it is recommended to install the tubing and valves with about 1% (10 mm/m) slope for long runs and 2% (20 mm/m) slope for short runs. This is recommended to ensure the complete drainability of the process system. Drainability in the process system is ultimately the responsibility of the system designer and/or end user. Upon request, the tube end of the valve body is marked with a hash mark. If installed correctly, the hash mark must vertically cross the centerline of the tube end and be perpendicular to the pipe line. In addition, a template may be supplied for easy installation and adjustment of the drain angle.

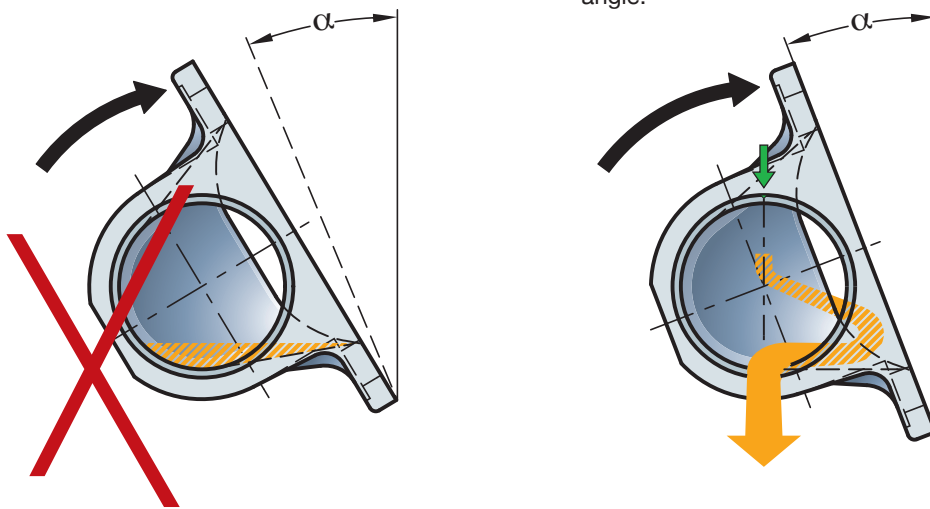

| VALVE-TYPE   | VALVE SIZE        |       |                   | SELF DRAINING ANGLE     |                               |                         |                         |                               |                         |
|--|-------------------|-------|-------------------|-------------------------|-------------------------------|-------------------------|-------------------------|-------------------------------|-------------------------|
|  | Tube end standard |       |                   | FORGED BODIES           |                               |                         | INVESTMENT CAST BODIES  |                               |                         |
|  |                   |       |                   | ISO 1127<br>DIN 11866-B | DIN 11850-1/-2<br>DIN 11866-A | ASME BPE<br>DIN 11866-C | ISO 1127<br>DIN 11866-B | DIN 11850-1/-2<br>DIN 11866-A | ASME BPE<br>DIN 11866-C |
|  | Code              | 40    | 41 / 42           | 45                      | 40                            | 41 / 42                 | 45                      |                               |                         |
| DN (mm)  | NPS (inch)        | MA    | $\alpha$ (Degree) |                         |                               | $\alpha$ (Degree)       |                         |                               |                         |
| 190<br>205 / 206<br>207 / 217<br>290 / 297                                     | 4                 | -     | 8                 | -                       | -                             | -                       | -                       | 22                            | -                       |
|  | 6                 | -     | 8                 | -                       | -                             | -                       | -                       | 22                            | -                       |
|  | 8                 | 1/4   | 8                 | 20,5                    | -                             | 33,2                    | 12,5                    | 22                            | 42                      |
|  | 10                | 3/8   | 8                 | -                       | 22,4                          | 28,4                    | -                       | 13,5                          | 28,8                    |
|  | 15                | 1/2   | 8                 | -                       | -                             | 25                      | -                       | -                             | 15,5                    |
| 188 / 195<br>295 / 289<br>317 / 392<br>394 / 397                               | 8                 | -     | 10                | 26,6                    | -                             | -                       | 31                      | -                             | -                       |
|  | 10                | 3/8   | 10                | 20,6                    | 27,5                          | 31,4                    | 21                      | 32                            | -                       |
|  | 15                | 1/2   | 10                | 12,8                    | 17,3                          | 28,8                    | 10,5                    | 16                            | 33                      |
|  | 20                | -     | 10                | -                       | 9,6                           | 17,4                    | -                       | 7                             | 16,5                    |
| 385 / 395 / 402<br>407 / 417 / 495<br>592 / 905 / 907 / 982<br>985 / 995 / 997 | 15                | 1/2   | 25                | 33,5                    | 35,8                          | 42,9                    | 39,5                    | 43                            | -                       |
|  | 20                | -     | 25                | 27,3                    | 31,5                          | 36,1                    | 29                      | 36                            | 43,5                    |
|  | 25                | 1     | 25                | 15,7                    | 19,9                          | 29,1                    | 20                      | 26                            | 32,5                    |
|  | 32                | 1 1/4 | 40                | 18,4                    | 24,7                          | 27,6                    | 21                      | 28,5                          | -                       |
|  | 40                | 1 1/2 | 40                | 12,3                    | 17,7                          | 21,5                    | 14                      | 21                            | 25                      |
|  | 50                | 2     | 50                | 12,4                    | 16,1                          | 18,5                    | 13,5                    | 19,5                          | 22,5                    |
|  | 65                | 2 1/2 | 50                | -                       | -                             | 12,4                    | 23                      | 30                            | 9                       |
|  | 65                | 2 1/2 | 80                | 21,1                    | 23,3                          | 26,6                    | 23                      | 30                            | 30                      |
|  | 80                | 3     | 80                | 15,8                    | 15,8                          | 21,1                    | 17                      | 17                            | 23                      |
| 100  | 4                 | 100   | 17,1              | 18                      | 19,3                          | 19,5                    | 19,5                    | 19,5                          |                         |

MA = Diaphragm size  
 Drain angle tolerance is +/- 2 degrees for optimum drainability  
 All valve bodies are marked with the valid self draining angle.



# Innovative Design

SED offers three different series of manual and pneumatically operated aseptic diaphragm valves. The selection of each is influenced by different criteria, i. e. application, technical specification, process system and plant design, available space, and last but not least the TCO (total cost of ownership).

The following table shows an overview of the performance and features of the three different series: Steripur, KMA, and KMD.

This table can support your decision which makes it easy to find the optimum solution for your application.

| Position | Series<br>MA<br>Performance Features  | Steripur |    |      | KMA |    |                | KMD |          |
|----------|---|----------|----|------|-----|----|----------------|-----|----------|
|          |   | 8        | 10 | ≥ 25 | 8   | 10 | ≥ 25           | 10  | ≥ 25     |
| 1        | Stainless steel piston actuation  | ●        | ●  | ●    |     |    |                |     |          |
| 2        | Actuation with stainless steel manual bonnet or distance pieces   |          |    |      | ●   | ●  | ●              |     |          |
| 3        | Plastic actuation direct mounted to the valve body  |          |    |      |     |    |                | ●   | ●        |
| 4.1      | Compact Design  | ●        | ●  | ●    |     | ●  | Type 395 / 905 | ●   | Type 402 |
| 4.2      | Optional orientation of the air inlet port  | ●        | ●  | ●    | ●   |    | Type 395       | ●   | Type 402 |
| 5        | Actuation for two-way bodies and welded configurations  | ●        | ●  | ●    | ●   | ●  | ●              | ●   | ●        |
| 6        | Actuation suitable for two-way bodies, welded configurations, T-bodies, multiport bodies and tank bottom bodies                     | ●        | ●  | ●    | ●   | ●  | ●              |     |          |
| 7        | Optimized internal cleaning because of circumferential defined sealing angle between process diaphragm and valve body (CDSA-Design) | ●        | ●  | ●    | ●   | ●  | ●              | ●   | ●        |
| 8        | Flexible diaphragm suspension   | ●        | ●  | ●    | ●   | ●  | ●              | ●   | ●        |
| 9        | Encapsulated working diaphragm  |          | ●  | ●    |     | ●  | ●              | ●   | ●        |
| 10       | Low weight  |          |    |      |     |    | Type 395 / 905 | ●   | ●        |

MA = Diaphragm size

Positions 4 to 10 are explained individually and in detail on pages 31 to 33.

## Compact Design - Optional Orientation of the Air Inlet Port

The selection of the valve is determined by the necessary flow rate from which the nominal diameter of the valve is determined. Due to physical limitations of space and the principle of the valve designs, the ability to improve the compactness of the valve assemblies is with the actuators. The innovative designs of SED valve actuators offer specific advantages.

New process system and plant design standards require dead legs to be minimized. Dimensions of valve assemblies have significance if it affects dead legs in the process system which must be minimized as much as possible. When selecting welded configurations and multiport valves, the actuators size plays an important role in minimizing dead legs.

SED offers actuators in a compact design with the following features:

- The outside diameter of the actuators is the same size or smaller as the bonnet flange of the body. The bonnet encapsulates the diaphragm and connects the diaphragm, actuator and body.
- The direction of the control air connection (air inlet port) for the valve actuation can be orientated either in the flow direction or 90° to the flow direction.

It is possible to combine any different actuation models.



## Actuation for Two-Way Bodies and Welded Configurations Actuation suitable for Two-Way Bodies, Welded Configurations, T-Bodies, Multiport Bodies and Tank Bottom Bodies

Dependent on the valve body design two different ways of valve assembly are possible.

- Bottom Entry Assembly  
Two-way bodies and two-way body welded configurations allow for this kind of assembly. The advantage is having no bolt holes in the actuator and therefore no exposed parts like bolt threads, nuts, and washers. Ease of assembly for maintenance.  
This is the ideal design for sterile wash downs.

- Through Bolt Hole Actuator Assembly  
Through bolt hole assembly is suitable for all body versions, two-ways, welded configurations, T-bodies, multiport, and tank bottom bodies. Through bolt holes are not possible in some valve body designs because of interference with the interior flow path. Therefore the holes are drilled in the actuators and assembled with stud bolts threaded into the valve body.



T-valve with U-bend  
Valve KMA Series manually operated



T-Valve  
Steripur Series  
Pneumatically operated



Two-Way Valve  
Steripur Series  
Manual

## Optimized Internal Cleaning because of Circumferential Defined Sealing Angle (CDSA-Design) between the Process Diaphragm and Valve Body

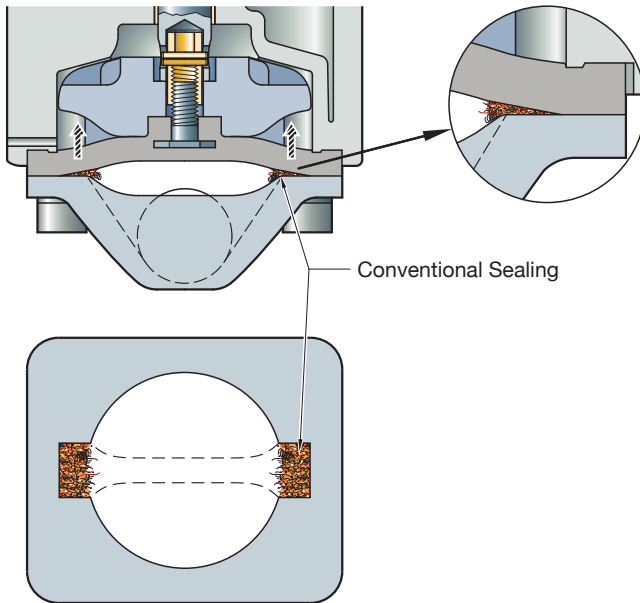

To achieve the highest level of sterility, the SED CDSA-Design Series was developed by utilizing new, qualified, and tested diaphragm valve technology. This unique design of the actuator reduces or eliminates product entrapment at the point beyond the radius of the weir on the body bonnet flange.

The CDSA sealing concept is achieved by the compressor being guided by the interior circular actuator lower housing providing a circumferential defined sealing angle at 360°. This reduces or eliminates entrapment because the seal over the weir and the circumference of the interior valve body is at the point and angle where the diaphragm and valve body meet.

The conventional weir style design in the market does not provide this feature because the interior actuator lower housing has guidance for the compressor. Typically, these compressors are designed with ends or fingers that extend beyond the radius of the weir onto the internal bonnet flange. Therefore, a circumferential defined sealing angle is not possible.

### The effects of this design have the following advantages:

- Internal cleaning is more efficient and has been tested and qualified by EHEDG Document No. 08.
- Product entrapment reduced or eliminated on the body bonnet flange.
- Reduced cleaning time of SIP systems.
- Reduced use of chemicals and solutions in CIP systems.
- Improves valve drainability.
- Better sealing performance and evenly distributed closing force.
- Diaphragm lifetime is extended.

The same selection of diaphragms may be used for all SED series and versions of actuators.

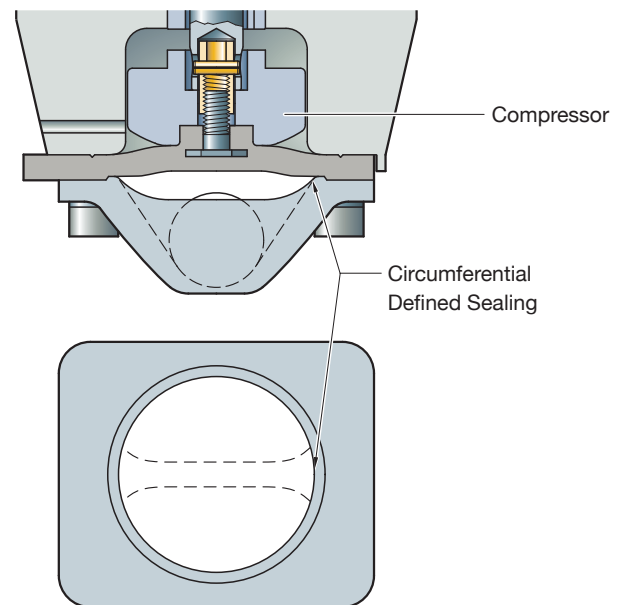



## Flexible Diaphragm Suspension

The flexible diaphragm suspension has different relevant performance depending on the selection of diaphragm material and type. The proper selection of diaphragm materials, type, and actuator components can eliminate point loading at center of the diaphragm. Point loading reduces the cycle life time of the diaphragm.

The smallest diaphragm size MA8 incorporates an elastomer button that is pressed into the compressor for connecting the diaphragm to the actuator. Because of the resilient elastomer material, it provides a flexible suspension throughout all the MA8 versions.

All other SED sizes have a threaded diaphragm stud for assembly to the spindle of the actuator. With the elastomer and one piece PTFE diaphragm versions, the threaded stud is vulcanized into the resilient elastomer material. This connection reduces the risk of point loading if properly assembled.

The two-piece PTFE and elastomer diaphragms have the threaded diaphragm stud embedded in the PTFE material. Point loading in center of the diaphragm in this case is almost unavoidable, resulting in diaphragm failure.

To eliminate point loading, SED supplies the flexible suspensions as standard for all valves that offer the option of using the two-piece diaphragm. The flexible diaphragm suspension assures that the closing force of the diaphragm will be absorbed by the elastomer of the diaphragm and the force evenly distributed across the weir of the body.

All of the SED diaphragms have the same assembly engagement by size regardless of the actuation or diaphragm materials and type. This is a tremendous advantage for diaphragm changes and replacement. There are systems in the market, i.e. bayonet connection and floating tube nut which require changing the spindle or compressor for different diaphragm materials and type.

This is not necessary with SED, select the valve and actuator and you may change to any of the SED diaphragm options without any additional parts or components.

The flexible diaphragm suspension is produced from a two-piece spindle in order to provide the necessary tolerance and scope between the two pieces. (See below illustration).

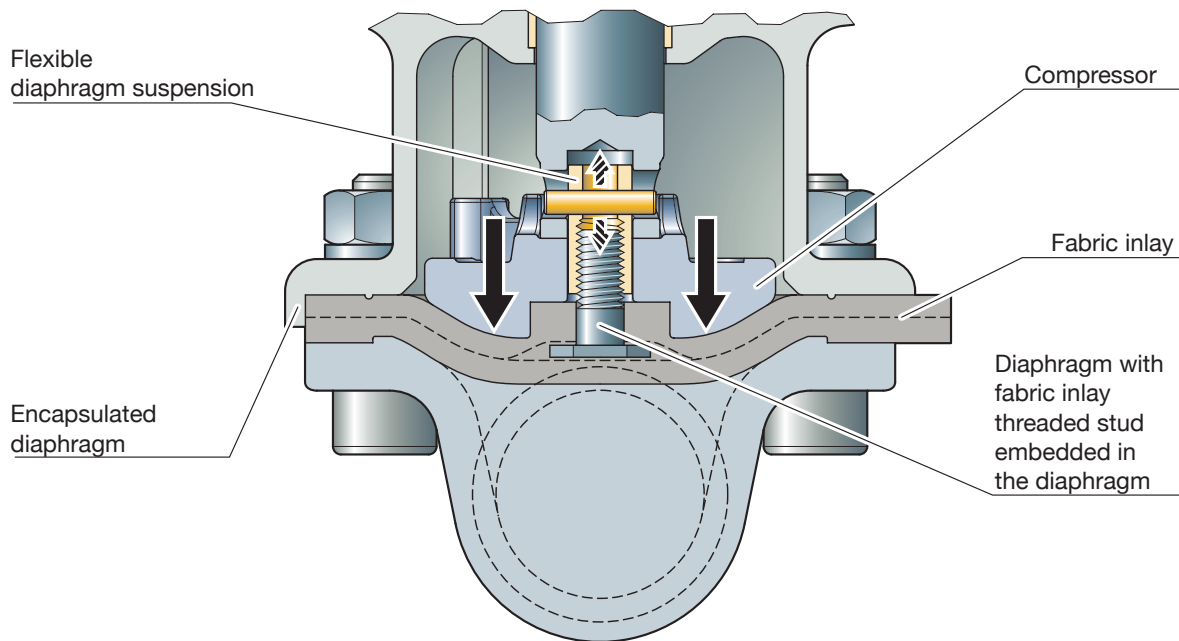

## Encapsulated Working Diaphragm

All SED actuators partially encapsulate the process diaphragm. This prevents the elastomer of the diaphragm from extruding beyond the body bonnet flange.

The encapsulated diaphragm offers a positive visual appearance of an assembled valve and reduces the risk of leakage to the exterior through the decrease of the diaphragm clamping. This is an important feature especially for higher temperature and pressure applications.

# Steripur 206

## Manual Valve DN 4 - 15 mm (1/4" - 1/2")



### Features

- **Stainless steel bonnet and hand wheel**
- Autoclavable
- Rising hand wheel
- Sealed bonnet with optical indicator
- Adjustable internal travel stop
- CDSA sealing concept, see page 32
- Flexible diaphragm suspension

### Optional

- Locking device

### Technical Data

|                           |  |
|---------------------------|--|
| Control function:         | Manually operated  |
| Max. working pressure:    | 10 bar (150 psi)   |
| Max. working temperature: | 160°C (320°F) dependent on application   |
| Diaphragm material:       | EPDM or PTFE   |
| Body material:            | Forged 1.4435/ 316L ASME/BPE<br>Investment cast 1.4435/ 316L<br>Other Alloys                   |
| End connection:           | Butt weld ends see fold out page 21<br>Clamps and flanges see page 22 to 24<br>Special ends    |
| Bonnets suitable for:     | Two-Way bodies<br>Welded configurations<br>T- bodies<br>Multiport bodies<br>Tank bottom bodies |
| Flow rate:                | Kv in m <sup>3</sup> /h (Cv in GPM) see page 9   |
| Diaphragm size:           | MA 8   |
| Weight:                   | ca. 0,3 kg   |

Technical data also valid for multiport valve.

Butt weld ends  
MA 8  
Fold out page 21

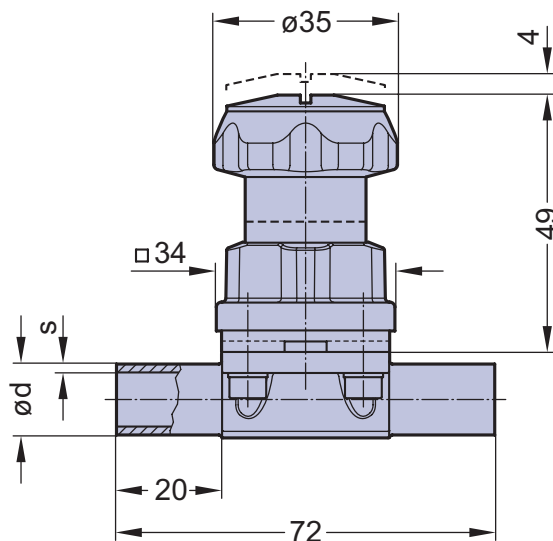

Valve type overview see page 26 and 27.  
Ordering key see page 66 to 68.

# Steripur 397

## Manual Valve DN 8 - 20 mm (3/8" - 3/4")



### Features

- Stainless steel bonnet and hand wheel
- Autoclavable
- Rising hand wheel
- Sealed bonnet with optical indicator
- Adjustable internal travel stop
- CDSA sealing concept, see page 32
- Flexible diaphragm suspension
- Encapsulated diaphragm

### Optional

- Locking device

### Technical Data

Control function: Manually operated  
 Max. working pressure: 10 bar (150 psi)

Max. working temperature: 160°C (320°F)  
 dependent on application

Diaphragm material: EPDM or PTFE  
 Body material: Forged 1.4435/ 316L ASME/BPE  
 Investment cast 1.4435/ 316L  
 Other Alloys

End connection: Butt weld ends see fold out page 21  
 Clamps and flanges see page 22 to 24  
 Special ends

Bonnets suitable for: Two-Way bodies / Welded configurations  
 T- bodies / Multiport bodies  
 Tank bottom bodies

Flow rate: Kv in m³/h (Cv in GPM) see page 9  
 Diaphragm size: MA 10  
 Weight: ca. 0,8 kg

Technical data also valid for multiport valve.

Butt weld ends  
 MA 10  
 Fold out page 21

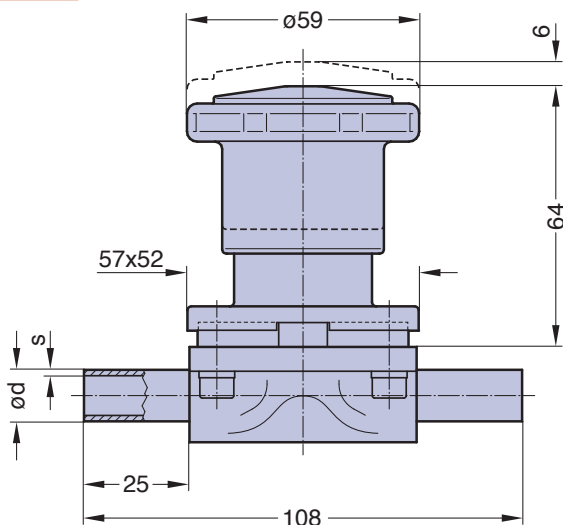

Valve type overview see page 26 and 27.  
 Ordering key see page 66 to 68.

# Steripur 907

## Manual Valve DN 15 - 50 mm (3/4" - 2 1/2")



Steripur 907, T01

### Features

- **Stainless steel bonnet and hand wheel**
- Autoclavable
- Rising hand wheel with optical indicator and stroke indicator
- Sealed bonnet
- Internal travel stop
- Locking device
- CDSA sealing concept, see page 32
- Flexible diaphragm suspension
- Encapsulated diaphragm

### Optional

- Adjustable internal stroke limiter
- U-Lock for hand wheel
- Assembly of proximity switches

### Technical Data

|  |  |
|--|--|
| Control function:                              | Manually operated  |
| Max. working pressure:                         | 10 bar (150 psi)   |
| Max. working temperature:                      | 160°C (320°F) dependent on application   |
| Diaphragm material:                            | EPDM or PTFE   |
| Valve body material:                           | Forged 1.4435/ 316L ASME/BPE<br>Investment cast 1.4435/ 316L<br>Other Alloys                   |
| End connection:                                | Butt weld ends see fold out page 21<br>Clamps and flanges see page 22 to 24<br>Special ends    |
| Bonnets suitable for:                          | Two-Way bodies<br>Welded configurations<br>T- bodies<br>Multiport bodies<br>Tank bottom bodies |
| Flow rate:                                     | Kv in m <sup>3</sup> /h (Cv in GPM) see page 9   |
| Diaphragm size:                                | MA see table   |
| Technical data also valid for multiport valve. |  |

Butt weld ends  
MA 25 - 50  
Fold out page 21

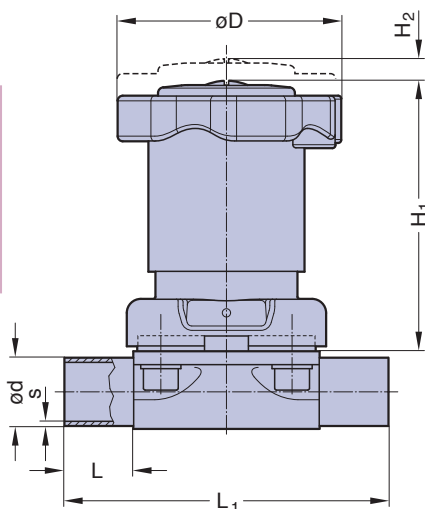

| DN<br>(mm) | MA | Dimensions (mm) |                |                |                |     | Total weight ca. (kg)<br>Steripur 907 |        |
|------------|----|-----------------|----------------|----------------|----------------|-----|---------------------------------------|--------|
|            |    | L               | L <sub>1</sub> | H <sub>1</sub> | H <sub>2</sub> | D   | Investment<br>cast                    | Forged |
| 15-25      | 25 | 25              | 120            | 100            | 10             | 84  | 2,1                                   | 2,2    |
| 32-40      | 40 | 25              | 153            | 119            | 16             | 112 | 3,5                                   | 3,7    |
| 50         | 50 | 30              | 173            | 136            | 20             | 135 | 4,8                                   | 5,9    |

Valve type overview see page 26 and 27.  
Ordering key see page 66 to 68.

## Manual Valve DN 65 - 100 mm (3/4" - 4")



DN 65 - 100

### Features

- **Stainless steel bonnet and hand wheel**
- Non rising hand wheel with optical indicator
- Sealed bonnet
- Autoclavable
- CDSA sealing concept, see page 32
- Flexible diaphragm suspension
- Encapsulated diaphragm

### Optional

- Adjustable internal travel stop or stroke limiter
- Sealed bonnet
- Locking device

### Technical Data

Control function: Manually operated  
 Max. working pressure: 10 bar (150 psi)  
 DN 65-100 diaphragm PTFE 8 bar (115 psi)  
 Max. working temperature: 160°C (320°F) dependent on application  
 Diaphragm material: EPDM or PTFE  
 Valve body material: Forged 1.4435/ 316L ASME/BPE  
 Investment cast 1.4435/ 316L  
 Other Alloys  
 End connection: Butt weld ends see fold out page 21  
 Clamps and flanges see page 22 to 24  
 Special ends  
 Bonnets suitable for: Two-Way bodies  
 Welded configurations  
 T- bodies  
 Multiport bodies  
 Tank bottom bodies  
 Flow rate: Kv in m<sup>3</sup>/h (Cv in GPM) see page 9  
 Diaphragm size: MA see table  
 Technical data also valid for multiport valve.

Butt weld ends  
 MA 25 - 100  
 Fold out page 21

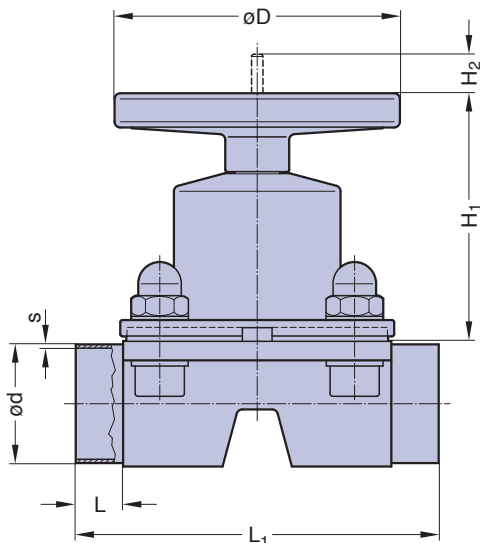

DN 65 - 100 (Drawing MA 80)

| DN<br>(mm) | MA  | Dimensions (mm) |                |                |                |     | Total weight ca. (kg) |        |
|------------|-----|-----------------|----------------|----------------|----------------|-----|-----------------------|--------|
|            |     | L               | L <sub>1</sub> | H <sub>1</sub> | H <sub>2</sub> | D   | Investment<br>cast    | Forged |
| 65         | 80  | 30              | 216            | 180            | 38             | 198 | 13,0                  | 15,0   |
| 80         | 80  | 30              | 254            | 180            | 38             | 198 | 13,0                  | 15,0   |
| 100        | 100 | 30              | 305            | 220            | 50             | 252 | 22,0                  | 20,0   |

Valve type overview see page 26 and 27.  
 Ordering key see page 66 to 68.

# Steripur 217

## Pneumatically Operated Valve DN 4 - 15 mm (1/4" - 1/2")

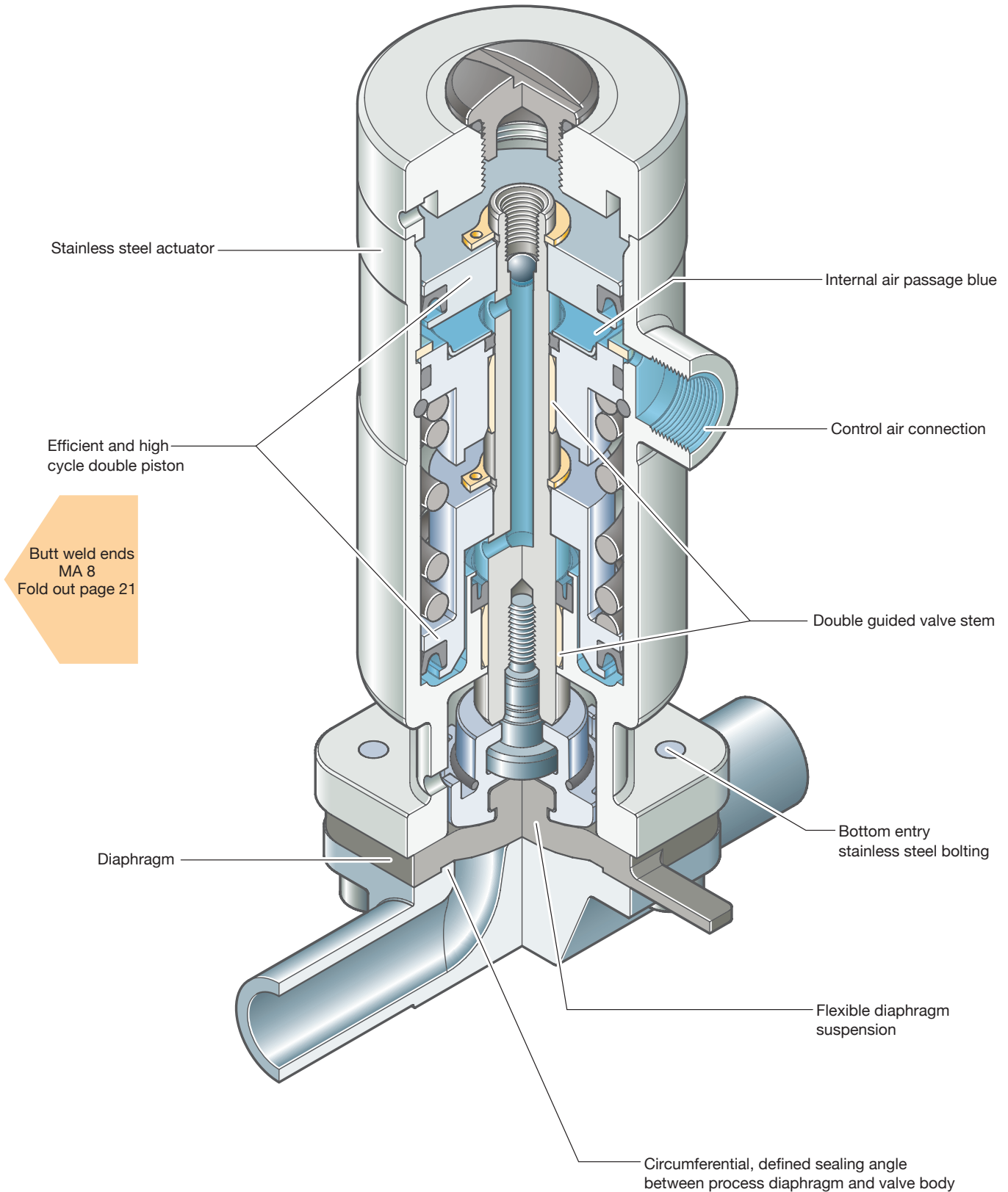

Sectional drawing shows Steripur 217.30

## Pneumatically Operated Valve DN 4 - 15 mm (1/4" - 1/2")



217.30 Cf. 4



217.25 Cf. 5 & 6

This valve is available in two different designs.

The type 217.30 is available in the control function fail safe close and performs at a higher working pressure for standard application. Advantages of the type 217.25 are a very high cycle life and a smaller overall dimensional height. Type 217.25 is available in control functions fail safe open and double acting for standard working pressures.

### Features

- **High cycle stainless steel piston actuator**  
Type 217.30 with double piston
- Compact design, the outside diameter of the actuator is the same size as the bonnet flange connecting diaphragm and body
- Advantages in multiport bodies and manifold valve assemblies
- Low control air volume, high switching speed
- High repeatability
- Control air connection on the top, away from the process product line
- Direction of control air connection is mountable in 90° rotations
- CDSA sealing concept, see page 32
- Flexible diaphragm suspension
- Clean and polished exterior design ideal for sterile wash downs

### Optional

- Available with a wide range of control equipment and accessories see page 132 to 139 for this options
- Autoclavable

### Technical Data

- Control function (Cf.): Pneumatically operated
- 217.30: Fail safe close (NC): Cf. 1 & 4  
217.25: Fail safe open (NO): Cf. 2 & 5  
Double acting (DA): Cf. 3 & 6  
At control function NO/DA higher control pressure than required may affect the lifetime of the working diaphragm.
- Direction  
Control connection: At Cf. 4, 5 & 6 in flow direction, standard  
At Cf. 1, 2 & 3, 90° to flow direction
- Max. working pressure: Unidirectional (delta p = 100%)  
217.30: Cf: Fail safe close  
EPDM diaphragm 8 bar (115 psi)  
PTFE diaphragm 7 bar (100 psi)  
217.25: Cf: Fail safe open and double acting  
EPDM diaphragm 8 bar (115 psi)  
PTFE diaphragm 7 bar (100 psi)

Higher working pressure may be achieved with different actuator. Please consult a SED factory representative for working pressure above the indicated maximum.

Max. working temperature: 160°C (320°F) dependent on application

- Control pressure:
- 217.30: Cf. 1 & 4 4 - 7 bar (60 - 100 psi)  
Cf. 1 & 4 5,5 - 7 bar (80 - 100 psi)  
217.25: Cf. 2, 3, 5 & 6 5,5 - 7 bar (80 - 100 psi)

- Diaphragm material: EPDM or PTFE  
Valve body material: Forged 1.4435/ 316 L ASME/BPE  
Investment cast 1.4435/ 316 L  
Other alloys

- End connection: Butt weld ends see fold out page 21  
Clamps and flanges see page 22 to 24  
Special ends

- Actuators suitable for: Two-Way bodies, Welded configurations, T-bodies, Multiport bodies, Tank bottom bodies

Flow rate: Kv in m<sup>3</sup>/h (Cv in GPM) see page 9

Diaphragm size: MA 8

- Weight: 217.30: ca. 0,45 kg  
217.25: ca. 0,44 kg

Technical data also valid for multiport valve.

| Type   | MA | Filling volume (NL) |       |
|--------|----|---------------------|-------|
|        |    | NC                  | NO/DA |
| 217.25 | 8  |                     | 0,013 |
| 217.30 | 8  | 0,013               |       |

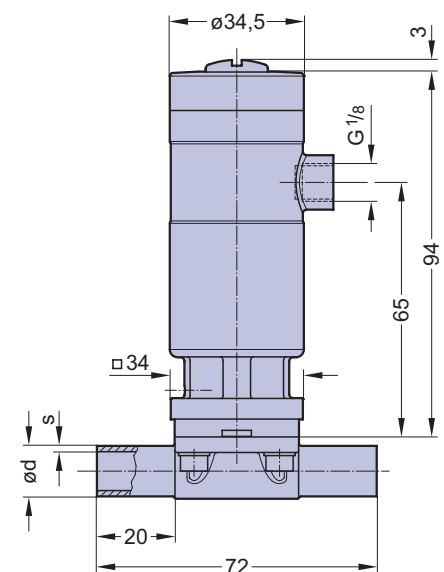
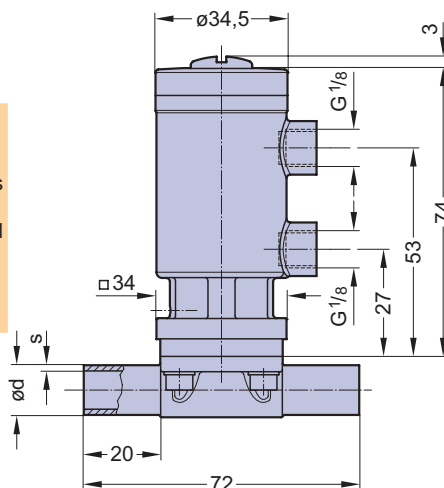

Butt weld ends  
MA 8  
Fold out page 21

Valve type overview see page 26 and 27.  
Ordering key see page 66 to 68.

# Steripur 317

## Pneumatically Operated Valve DN 8 - 20 mm (3/8" - 3/4")



Cf. 4

### Features

- High cycle stainless steel piston actuator
- Compact design, the outside diameter of the actuator is the same size as the bonnet flange
- Advantages in multiport bodies and manifold valve assemblies
- Control air connection in flow direction
- CDSA sealing concept, see page 32
- Flexible diaphragm suspension
- Encapsulated diaphragm
- Clean and polished exterior design ideal for sterile wash downs

### Optional

- Available with a wide range of control equipment and accessories see page 132 to 139, also for retrofitting
- Control air connection 90° to flow direction
- Autoclavable

### Technical Data

- Control function (Cf.): Pneumatically operated  
 Fail safe close (NC): Cf. 1 & 4  
 Fail safe open (NO): Cf. 2 & 5  
 Double acting (DA): Cf. 3 & 6  
 At control function NO/DA higher control pressure than required may affect the lifetime of the working diaphragm.
- Direction  
 Control connection: At Cf. 4, 5 & 6 in flow direction, standard  
 At Cf. 1, 2 & 3, 90° to flow direction
- Max. working pressure: Unidirectional (delta p = 100%)  
 EPDM diaphragm 8 bar (115 psi)  
 PTFE diaphragm 7 bar (100 psi)

Higher working pressure may be achieved with different actuator. Please consult a SED factory representative for working pressure above the indicated maximum.

- Max. working temperature: 160°C (320°F) dependent on application
- Control pressure: Cf. 1 & 4 4,2 - 7 bar (60 - 100 psi)  
 Cf. 2, 3, 5 & 6 4 - 5 bar (60 - 72 psi)
- Diaphragm material: EPDM or PTFE
- Valve body material: Forged 1.4435/ 316 L ASME/BPE  
 Investment cast 1.4435/ 316 L  
 Other alloys
- End connection: Butt weld ends see fold out page 21  
 Clamps and flanges see page 22 to 24  
 Special ends
- Actuators suitable for: Two-Way bodies  
 Welded configurations  
 T-bodies  
 Multiport bodies  
 Tank bottom bodies
- Flow rate: Kv in m³/h (Cv in GPM) see page 9
- Diaphragm size: MA 10
- Weight: ca. 1,0 kg

Technical data also valid for multiport valve.

| DN<br>(mm) | MA | Filling volume (NL) |       |
|------------|----|---------------------|-------|
|            |    | NC                  | NO/DA |
| 8-20       | 25 | 0,035               | 0,030 |

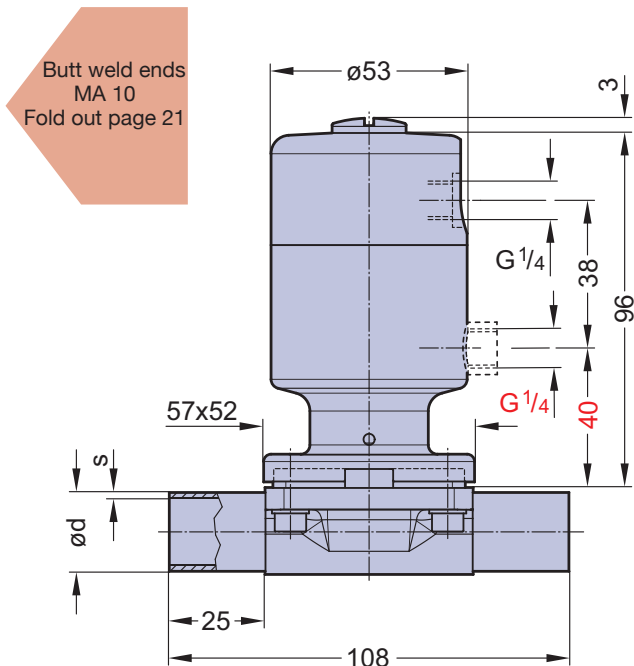

Red indicated values for DA Version

Valve type overview see page 26 and 27.  
 Ordering key see page 66 to 68.



## Pneumatically Operated Valve DN 65 - 100 mm (2 1/2" - 4")



### Features

- High cycle stainless steel piston actuator
- Compact design, the outside diameter of the actuator is the same size as the bonnet flange
- Advantages in multiport bodies and manifold valve assemblies
- Control air connection in flow direction
- CDSA sealing concept, see page 32
- Flexible diaphragm suspension
- Encapsulated diaphragm
- Clean and polished exterior design ideal for sterile wash downs

### Optional

- Available with a wide range of control equipment and accessories see page 132 to 139, also for retrofitting
- Control air connection 90° to flow direction
- Autoclavable

### Technical Data

Control function (Cf.): Pneumatically operated  
 Fail safe close (NC): Cf. 1 & 4  
 Fail safe open (NO): Cf. 2 & 5  
 Double acting (DA): Cf. 3 & 6  
 At control function NO/DA higher control pressure than required may affect the lifetime of the working diaphragm.

### Direction

Control connection: At Cf. 4, 5 & 6, in flow direction, standard  
 At Cf. 1, 2 & 3, 90° to flow direction

Max. working pressure: Unidirectional (delta p = 100%)

| Diaphragm | DN 65-80 (2,5"-3") | DN 100 (4")    |
|-----------|--------------------|----------------|
| EPDM      | 7 bar (100 psi)    | 6 bar (87 psi) |
| PTFE      | 6 bar (87 psi)     | 5 bar (72 psi) |

Higher working pressure may be achieved with different actuator. Please consult a SED factory representative for working pressure above the indicated maximum.

Max. working temperature: 160°C (320°F) dependent on application

Control pressure: Cf. 1 & 4 DN 65-80 5 - 8 bar(72-115 psi)  
 Cf. 1 & 4 DN 100 6 - 8 bar(87-115 psi)  
 Cf. 2, 3, 5 & 6 DN 65-80 4,5-6 bar(65-87 psi)  
 Cf. 2, 3, 5 & 6 DN 100 5,5-7 bar(80-100 psi)

Diaphragm material: EPDM or PTFE  
 Valve body material: Forged 1.4435/ 316 L ASME/BPE  
 Investment cast 1.4435/ 316 L  
 Other alloys

End connection: Butt weld ends see fold out page 21  
 Clamps and flanges see page 22 to 24  
 Special ends

Actuators suitable for: Two-Way bodies  
 Welded configurations  
 T-bodies  
 Multiport bodies  
 Tank bottom bodies

Flow rate: Kv in m3/h (Cv in GPM) see page 9  
 Diaphragm size: MA see table below

Technical data also valid for multiport valve.

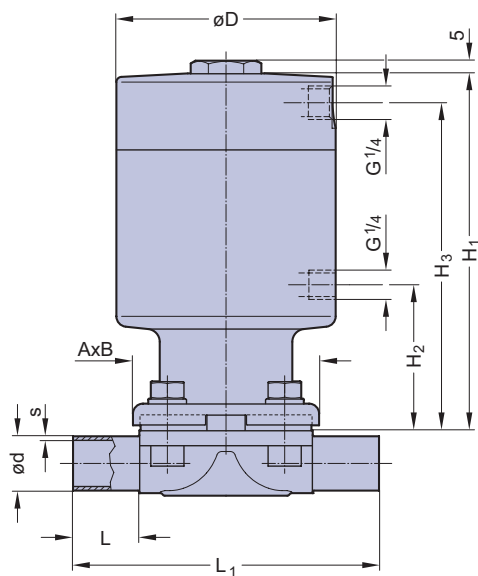

Butt weld ends  
 MA 25 - 100  
 Fold out page 21

| DN (mm) | MA  | Dimensions (mm) |                |         |                |                |                |     | Total weight ca. (kg) |        |
|---------|-----|-----------------|----------------|---------|----------------|----------------|----------------|-----|-----------------------|--------|
|         |     | L               | L <sub>1</sub> | A x B   | H <sub>1</sub> | H <sub>2</sub> | H <sub>3</sub> | D   | Investment cast       | Forged |
| 65      | 80  | 30              | 216            | 170x190 | 309            | 135            | 285            | 179 | 23,0                  | 26,0   |
| 80      | 80  | 30              | 254            | 170x190 | 309            | 135            | 285            | 179 | 23,0                  | 26,0   |
| 100     | 100 | 30              | 305            | ø238    | 318            | 143            | 295            | 179 | 33,0                  | 1,0    |

\* Cf. 2, 3, 5, 6 = 170

Valve type overview see page 26 and 27.  
 Ordering key see page 66 to 68.

# Steripur 417

## Pneumatically Operated Valve DN 15 - 50mm (3/4" - 2 1/2")

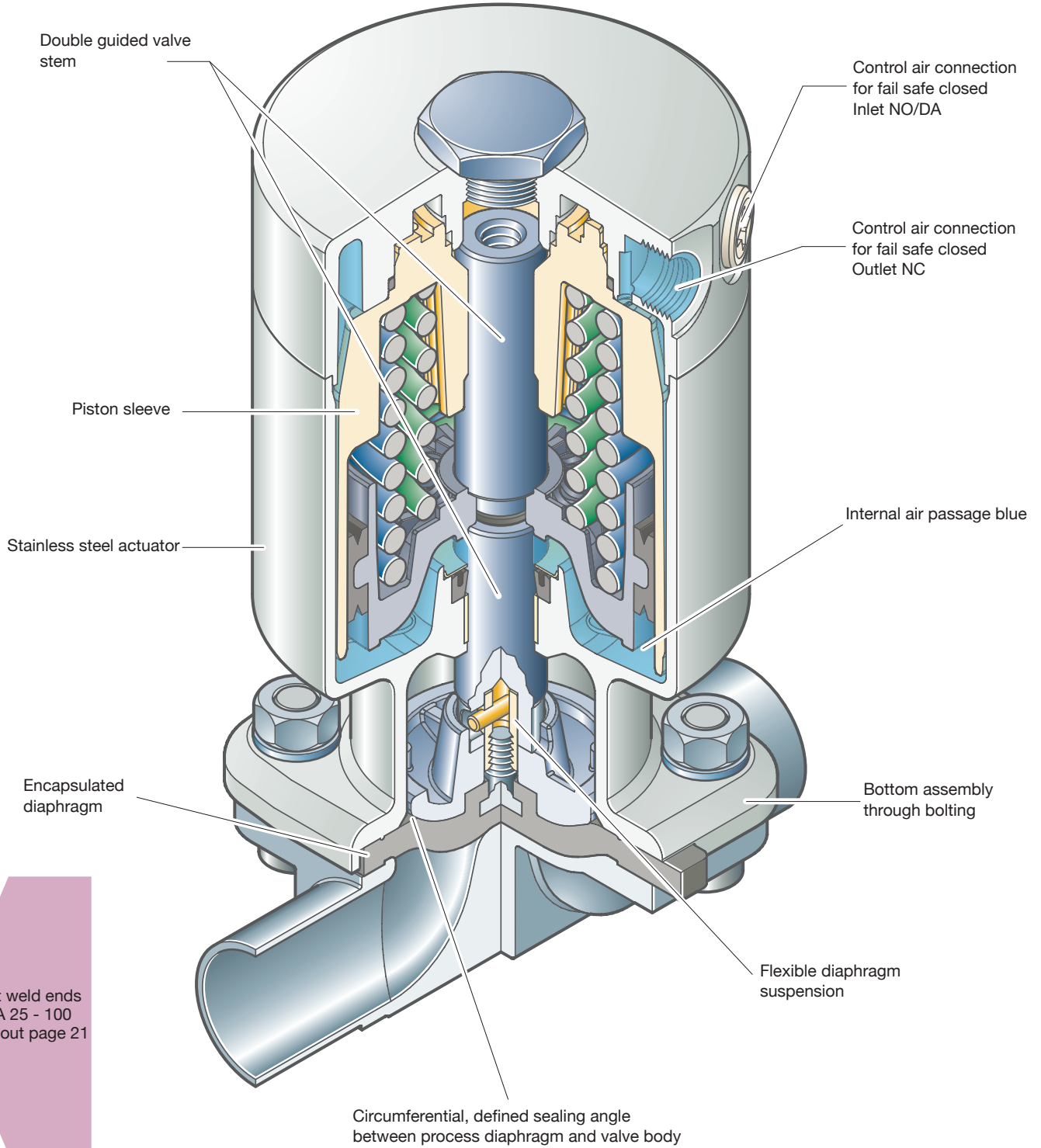

Butt weld ends  
MA 25 - 100  
Fold out page 21

## Pneumatically Operated Valve DN 15 - 50mm (3/4" - 2 1/2")



DN 15 - 50 Cf. 4, 5, 6

### Features

- High cycle stainless steel piston actuator
- Compact design, the outside diameter of the actuator is the same size as the bonnet flange
- Advantages in multiport bodies and manifold valve assemblies
- Control air connection in flow direction
- CDSA sealing concept, see page 32
- Flexible diaphragm suspension
- Encapsulated diaphragm
- Clean and polished exterior design ideal for sterile wash downs

### Optional

- Available with a wide range of control equipment and accessories see page 132 to 139, also for retrofitting
- Control air connection 90° to flow direction
- Autoclavable

### Technical Data

Control function (Cf.): Pneumatically operated  
 Fail safe close (NC): Cf. 1 & 4  
 Fail safe open (NO): Cf. 2 & 5  
 Double acting (DA): Cf. 3 & 6  
 At control function NO/DA higher control pressure than required may affect the lifetime of the working diaphragm.

Direction  
 Control connection: At Cf. 4, 5 & 6, in flow direction, standard  
 At Cf. 1, 2 & 3, 90° to flow direction

Max. working pressure: Unidirectional (delta p = 100%)

| Diaphragm | DN 15-50 (1/2"-2") |
|-----------|--------------------|
| EPDM      | 10 bar (150 psi)   |
| PTFE      | 8 bar (115 psi)    |

Higher working pressure may be achieved with different actuator. Please consult a SED factory representative for working pressure above the indicated maximum.

Max. working temperature: 160°C (320°F) dependent on application  
 Control pressure: Cf. 1 & 4 DN 15-50 4,5 - 8 bar(65-115 psi)  
 Cf. 2, 3, 5 & 6 DN 15-50 4,5-6 bar(65-87 psi)

Diaphragm material: EPDM or PTFE  
 Valve body material: Forged 1.4435/ 316 L ASME/BPE  
 Investment cast 1.4435/ 316 L  
 Other alloys

End connection: Butt weld ends see fold out page 21  
 Clamps and flanges see page 22 to 24  
 Special ends

Actuators suitable for: Two-Way bodies  
 Welded configurations  
 T-bodies  
 Multiport bodies  
 Tank bottom bodies

Flow rate: Kv in m<sup>3</sup>/h (Cv in GPM) see page 9  
 Diaphragm size: MA see table below

Technical data also valid for multiport valve.

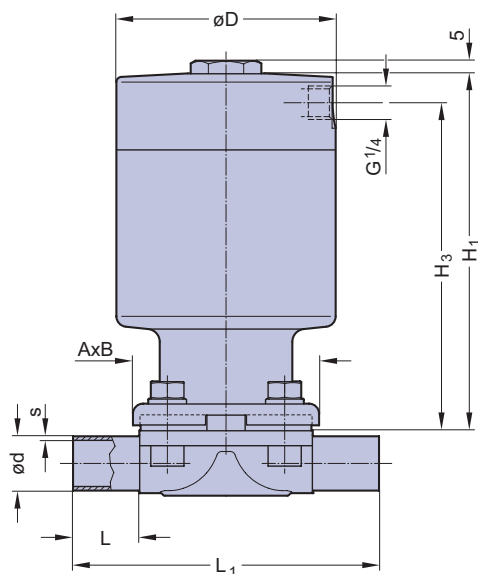

Butt weld ends  
 MA 25 - 100  
 Fold out page 21

| DN (mm) | MA | Dimensions (mm) |                |         |                |                |     | Total weight ca. (kg) |        | Filling volume (NL) |       |
|---------|----|-----------------|----------------|---------|----------------|----------------|-----|-----------------------|--------|---------------------|-------|
|         |    | L               | L <sub>1</sub> | A x B   | H <sub>1</sub> | H <sub>3</sub> | D   | Investment cast       | Forged | NC                  | NO/DA |
| 15-25   | 25 | 25              | 120            | 73x79   | 140            | 129            | 86  | 2,6                   | 2,7    | 0,15                | 0,15  |
| 32-40   | 40 | 25              | 153            | 96x105  | 167            | 155            | 111 | 5,0                   | 6,0    | 0,34                | 0,30  |
| 50      | 50 | 30              | 173            | 111x130 | 190            | 176            | 136 | 9,0                   | 10,0   | 0,60                | 0,54  |

Valve type overview see page 26 and 27.  
 Ordering key see page 66 to 68.

# Steripur 394

## Pneumatically Operated Valve DN 8 - 20 mm (3/8" - 3/4")

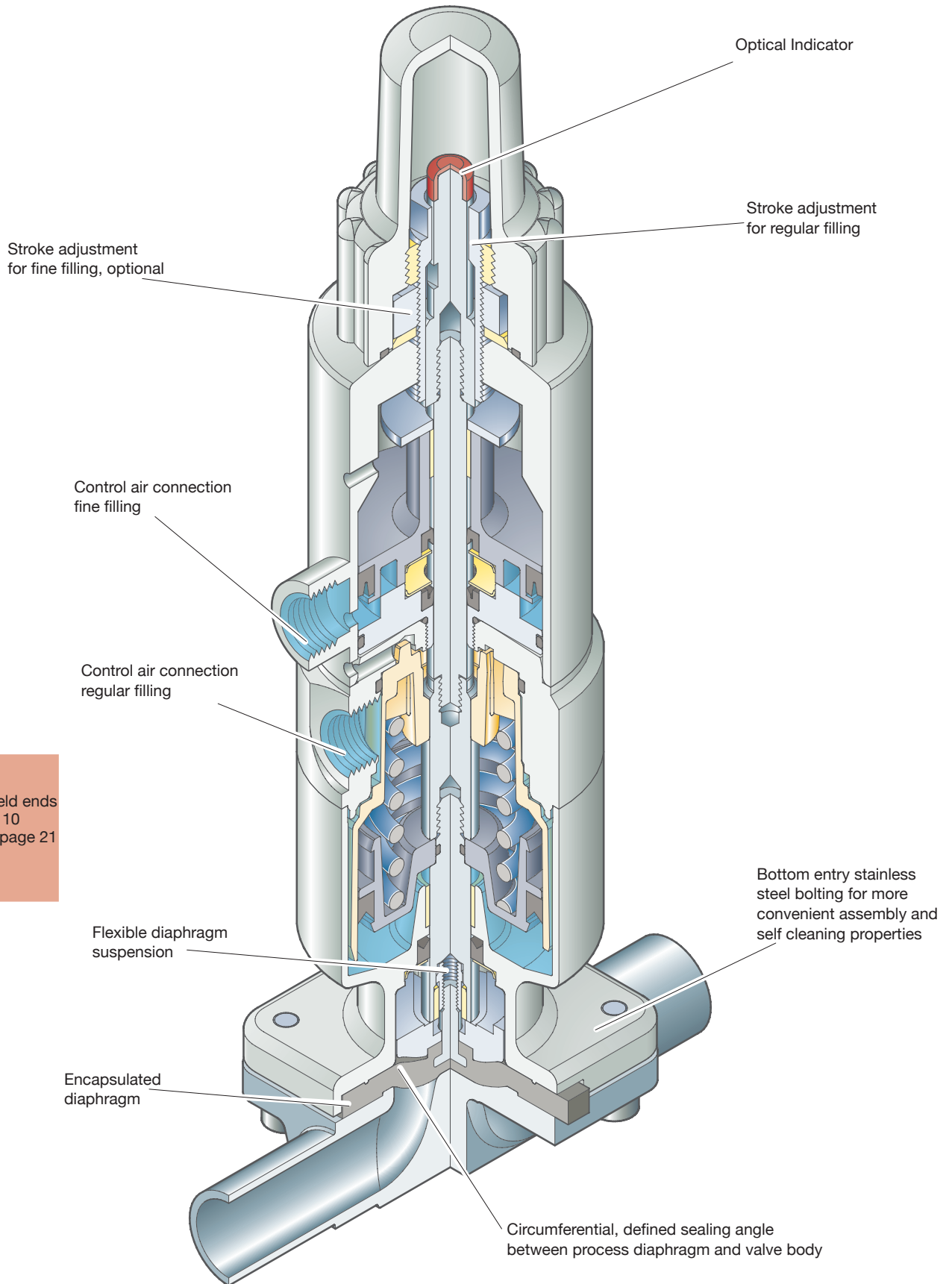

Butt weld ends  
MA 10  
Fold out page 21

Valve type overview see page 26 and 27.  
Ordering key see page 66 to 68.

## Pneumatically Operated Valve DN 8 - 20 mm (3/8" - 3/4")



### Features

- Two stage stainless steel actuator
- Second position adjustable with reduced flow for filling
- Compact design, the outside diameter of the actuator is the same size as the bonnet flange
- Advantages in multiport bodies and manifold valve assemblies
- Control air connection in flow direction
- CDSA sealing concept, see page 32
- Flexible diaphragm suspension
- Encapsulated diaphragm
- Clean and polished exterior design ideal for sterile wash downs
- Optical indicator

### Optional

- Available with a wide range of control equipment and accessories see page 132 to 139, also for retrofitting
- Control air connection 90° to flow direction
- Autoclavable
- Indication of 3 positions with 024.50, see page 138 and 139
- Fine filling adjustment

### Technical Data

Control function (Cf.): Pneumatically operated  
 Fail safe close (NC): Cf. 1 & 4  
 At control function NO/DA higher control pressure than required may affect the lifetime of the working diaphragm.

#### Direction

Control connection: At Cf. 4 in flow direction, standard  
 At Cf. 1, 90° to flow direction

Max. working pressure: Unidirectional (delta p = 100%)  
 EPDM Membrane 8 bar (115 psi)  
 PTFE Membrane 7 bar (100 psi)

Higher working pressure may be achieved with different actuator. Please consult a SED factory representative for working pressure above the indicated maximum.

Max. working temperature: 160°C (320°F) dependent on application

Control pressure: Cf. 1 & 4 4,5 - 7 bar (60 - 100 psi)

Diaphragm material: EPDM or PTFE

Valve body material: Forged 1.4435/ 316 L ASME/BPE  
 Investment cast 1.4435/ 316 L  
 Other alloys

End connection: Butt weld ends see fold out page 21  
 Clamps and flanges see page 22 to 24  
 Special ends

Actuators suitable for: Two-Way bodies  
 Welded configurations  
 T-bodies  
 Multiport bodies  
 Tank bottom bodies

Flow rate: Kv in m<sup>3</sup>/h (Cv in GPM) see page 9

Diaphragm size: MA 10

Weight: ca. 1,7 kg

Technical data also valid for multiport valve.

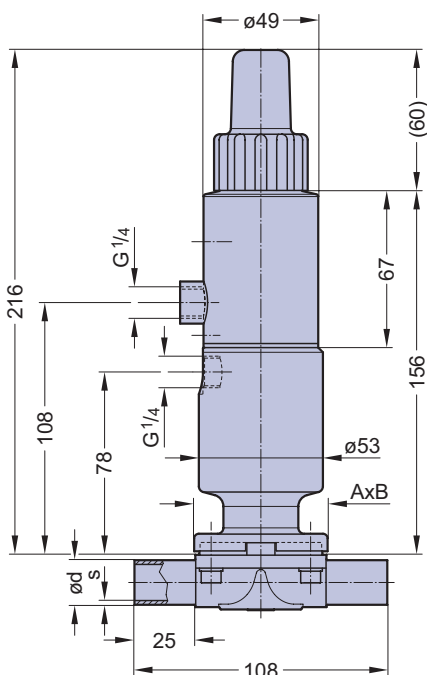

Butt weld ends  
 MA 10  
 Fold out page 21

| DN<br>(mm) | MA | Filling volume (NL) |
|------------|----|---------------------|
|            |    | NC                  |
| 8-20       | 25 | 0,061               |

Valve type overview see page 26 and 27.  
 Ordering key see page 66 to 68.

# Steripur 592

## Pneumatically Operated Valve DN 15 - 50 mm (3/4" - 2 1/2")



DN 50 Cf. 4

### Features

- Two stage stainless steel actuator
- Second position adjustable with reduced flow for filling
- Compact design, the outside diameter of the actuator is the same size as the bonnet flange
- Advantages in multiport bodies and manifold valve assemblies
- Control air connection in flow direction
- CDSA sealing concept, see page 32
- Flexible diaphragm suspension
- Encapsulated diaphragm
- Clean and polished exterior design ideal for sterile wash downs
- Optical indicator

### Optional

- Available with a wide range of control equipment and accessories see page 132 to 139, also for retrofitting
- Control air connection 90° to flow direction
- Autoclavable
- Indication of 3 positions with 024.50, see page 138 and 139

### Technical Data

Control function (Cf.): Pneumatically operated  
 Fail safe close (NC): Cf. 1 & 4  
 At control function NO/DA higher control pressure than required may affect the lifetime of the working diaphragm.

Direction

Control connection: At Cf. 4 in flow direction, standard  
 At Cf. 1, 90° to flow direction

Max. working pressure: Unidirectional (delta p = 100%)

| Diaphragm | DN 15 - 50 (1/2" - 2") |
|-----------|------------------------|
| EPDM      | 10 bar (150 psi)       |
| PTFE      | 8 bar (115 psi)        |

Higher working pressure may be achieved with different actuator. Please consult a SED factory representative for working pressure above the indicated maximum.

Max. working temperature: 160°C (320°F) dependent on application

Control pressure: Cf. 1 & 4 5 - 8 bar (72 - 115 psi)

Diaphragm material: EPDM or PTFE

Valve body material: Forged 1.4435/ 316 L ASME/BPE

Investment cast 1.4435/ 316 L

Other alloys

End connection: Butt weld ends see fold out page 21  
 Clamps and flanges see page 22 to 24  
 Special ends

Actuators suitable for: Two-Way bodies, Welded configurations,  
 T-bodies, Multiport bodies,  
 Tank bottom bodies

Flow rate: Kv in m<sup>3</sup>/h (Cv in GPM) see page 9

Diaphragm size: MA see table below

Technical data also valid for multiport valve.

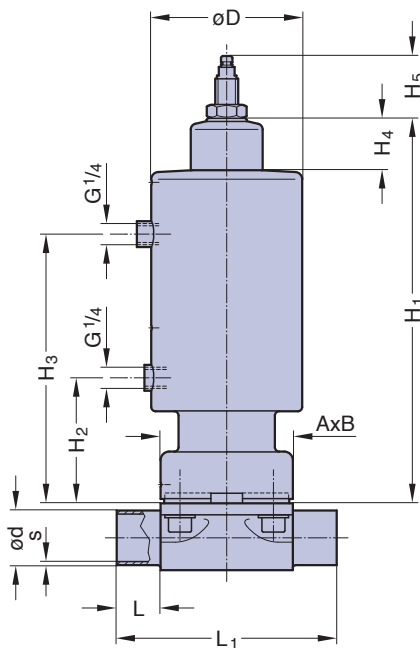

Butt weld ends  
 MA 25 - 50  
 Fold out page 21

| DN<br>(mm) | MA | Dimensions (mm) |                |         |                |                |                |                |                |     | Total weight ca. (kg) |        |
|------------|----|-----------------|----------------|---------|----------------|----------------|----------------|----------------|----------------|-----|-----------------------|--------|
|            |    | L               | L <sub>1</sub> | A x B   | H <sub>1</sub> | H <sub>2</sub> | H <sub>3</sub> | H <sub>4</sub> | H <sub>5</sub> | D   | Investment cast       | Forged |
| 15-25      | 25 | 25              | 120            | 73x79   | 220            | 66             | 150            | -              | 35             | 75  | 2,8                   | 2,9    |
| 32-40      | 40 | 25              | 153            | 96x105  | 250            | 75             | 185            | 28             | 40             | 105 | 7,0                   | 7,0    |
| 50         | 50 | 30              | 173            | 110x130 | 294            | 77             | 221            | 28             | 47             | 105 | 9,0                   | 10,0   |

Valve type overview see page 26 and 27.  
 Ordering key see page 66 to 68.



# KMA 205

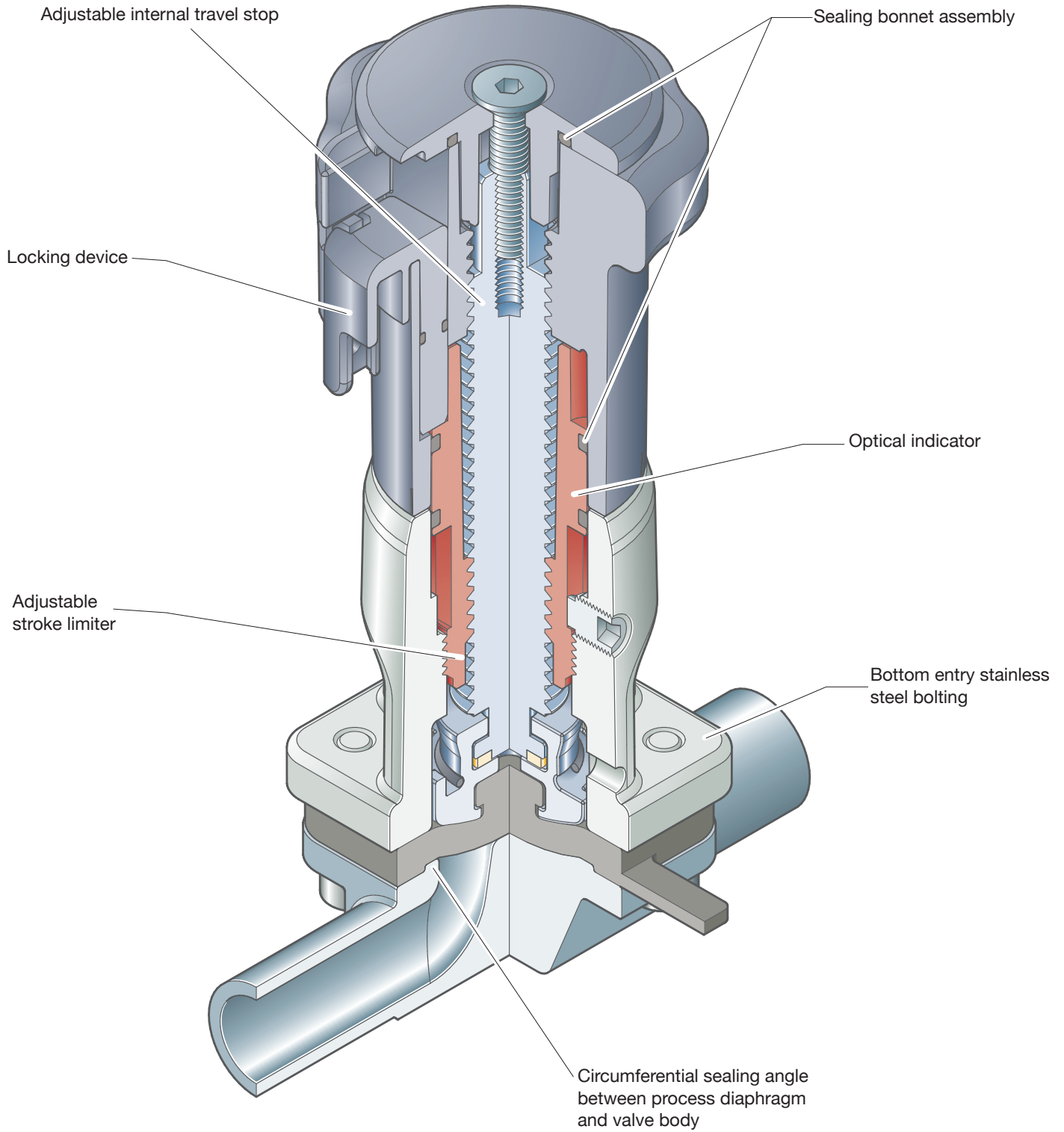



## Manual Valve DN 4 - 15 mm (1/4" - 1/2")



KMA 205, S03

### Features

- **Stainless steel bonnet and plastic hand wheel**
- Manual diaphragm Valve with plastic hand wheel is suitable for a limited number of cycles of autoclaving.
- Rising hand wheel
- Sealed bonnet with optical indicator
- Adjustable internal travel stop
- CDSA sealing concept, see page 32
- Flexible diaphragm suspension

### Specific features S02

- Adjustable internal stroke limiter
- Locking device

### Optional features S02

- U-Lock for hand wheel
- Assembly of proximity switches

### Technical Data

|                           |  |
|---------------------------|--|
| Control function:         | Manually operated  |
| Max. working pressure:    | 10 bar (150 psi)   |
| Max. working temperature: | 160°C (320°F) dependent on application   |
| Diaphragm material:       | EPDM or PTFE   |
| Body material:            | Forged 1.4435/ 316L ASME/BPE<br>Investment cast 1.4435/ 316L<br>Other Alloys                   |
| End connection:           | Butt weld ends see fold out page 21<br>Clamps and flanges see page 22 to 24<br>Special ends    |
| Bonnets suitable for:     | Two-Way bodies<br>Welded configurations<br>T- bodies<br>Multiport bodies<br>Tank bottom bodies |
| Flow rate:                | Kv in m <sup>3</sup> /h (Cv in GPM) see page 9   |
| Diaphragm size:           | MA 8   |
| Weight:                   | ca. 0,2 kg   |

Technical data also valid for multiport valve.

Butt weld ends  
MA 8  
Fold out page 21



KMA 205, S02

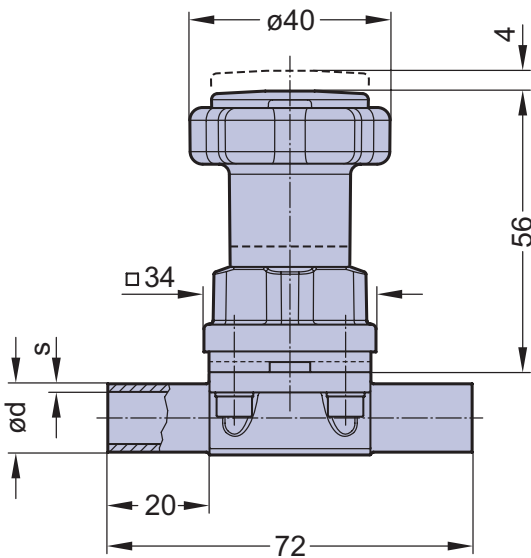

KMA 205

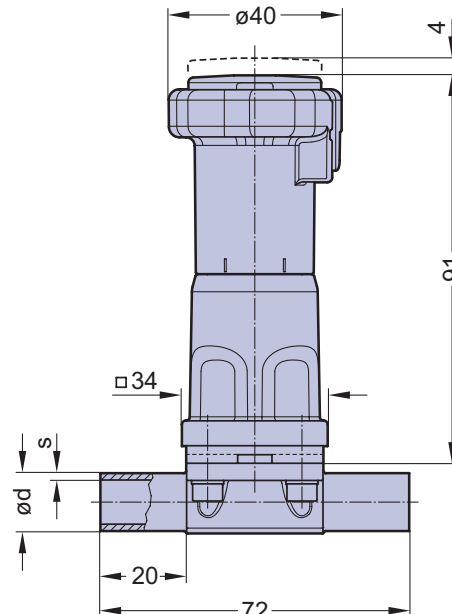

KMA 205

Valve type overview see page 26 and 27.  
Ordering key see page 66 to 68.

# KMA 295

## Manual Valve DN 8 - 20 mm (3/8" - 3/4")

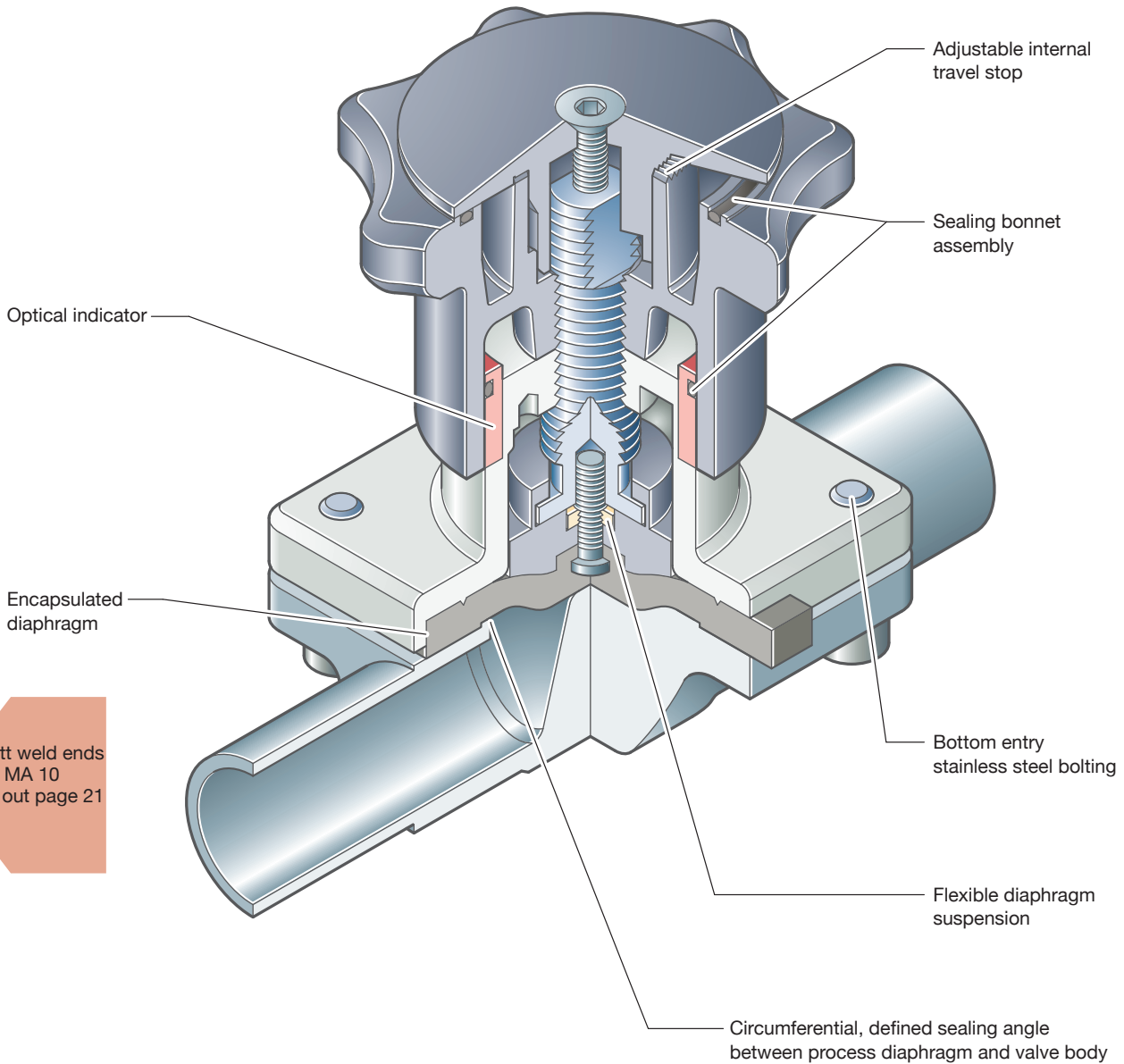

Butt weld ends  
MA 10  
Fold out page 21

## Manual Valve DN 8 - 20 mm (3/8" - 3/4")



### Features

- **Stainless steel bonnet and plastic hand wheel**
- Manual diaphragm Valve with plastic hand wheel is suitable for a limited number of cycles of autoclaving.
- Rising hand wheel
- Sealed bonnet with optical indicator
- Adjustable internal travel stop
- CDSA sealing concept, see page 32
- Flexible diaphragm suspension
- Encapsulated diaphragm

### Technical Data

|                           |  |
|---------------------------|--|
| Control function:         | Manually operated  |
| Max. working pressure:    | 10 bar (150 psi)   |
| Max. working temperature: | 160°C (320°F)<br>dependent on application  |
| Diaphragm material:       | EPDM or PTFE   |
| Body material:            | Forged 1.4435/ 316L ASME/BPE<br>Investment cast 1.4435/ 316L<br>Other Alloys                 |
| End connection:           | Butt weld ends see fold out page 21<br>Clamps and flanges see page 22 to 24<br>Special ends  |
| Bonnets suitable for:     | Two-Way bodies / Welded configurations<br>T- bodies / Multiport bodies<br>Tank bottom bodies |
| Flow rate:                | Kv in m <sup>3</sup> /h (Cv in GPM) see page 9   |
| Diaphragm size:           | MA 10  |
| Weight:                   | ca. 0,6 kg   |

Technical data also valid for multiport valve.

Butt weld ends  
MA 10  
Fold out page 21

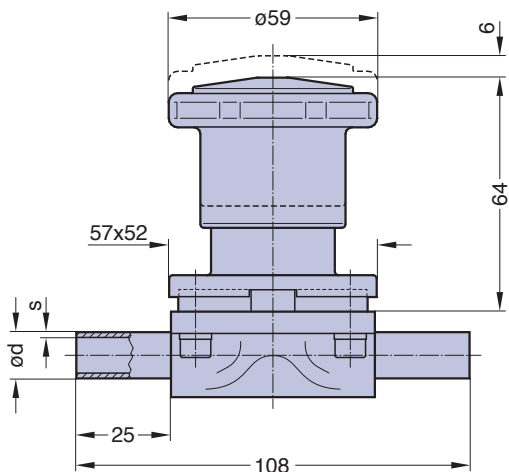

Valve type overview see page 26 and 27.  
Ordering key see page 66 to 68.

## Manual Valve DN 15 - 50 mm (3/4" - 2 1/2")

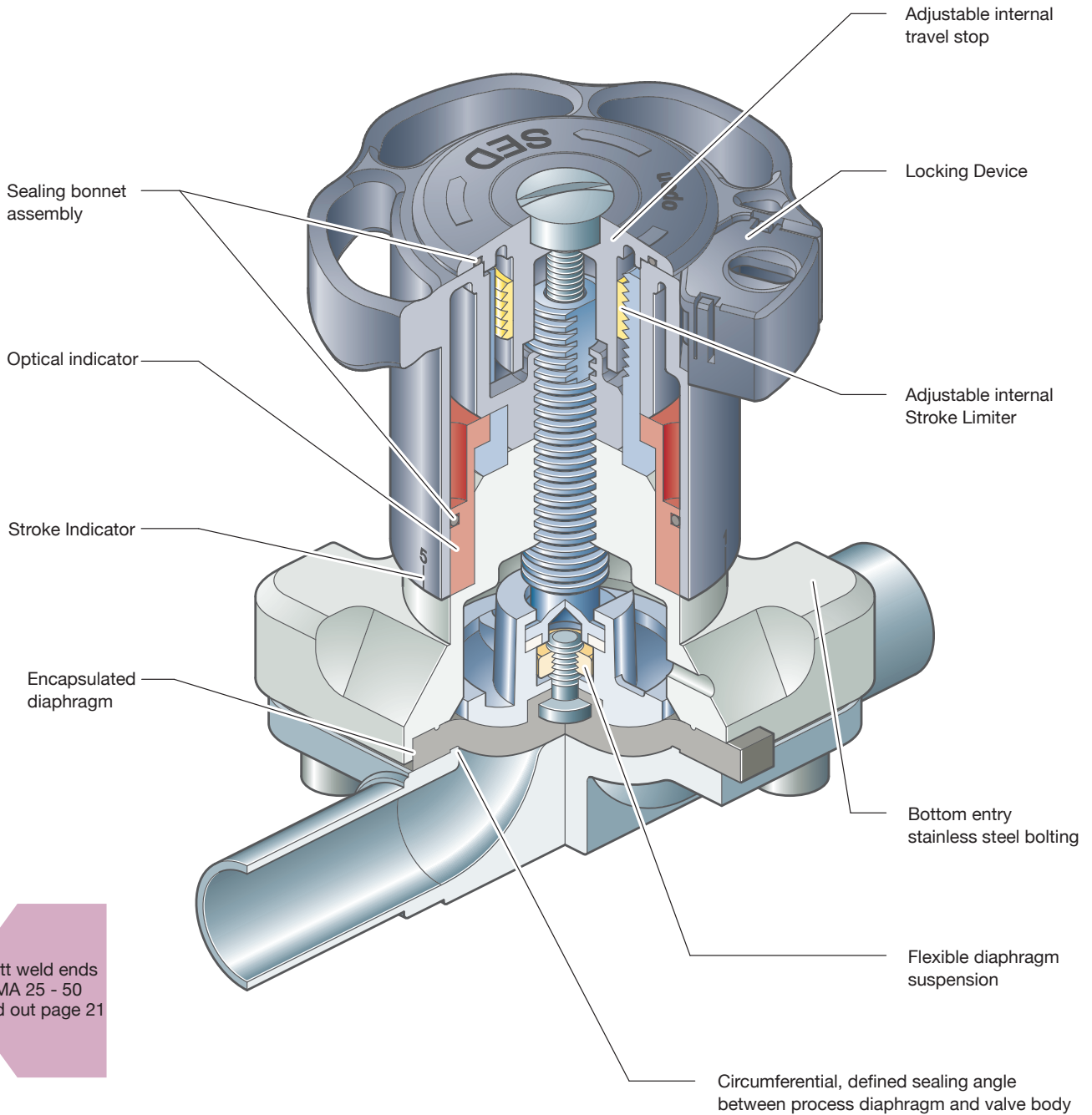

Butt weld ends  
MA 25 - 50  
Fold out page 21



Introduction Video  
<http://www.sed-flowcontrol.com/en/service/movies>

## Manual Valve DN 15 - 50 mm (3/4" - 2 1/2")



KMA 905 , S11

### Features

- **Stainless steel bonnet and plastic hand wheel**
- Manual diaphragm Valve with plastic hand wheel is suitable for a limited number of cycles of autoclaving.
- Rising hand wheel with optical indicator and stroke indicator
- Sealed bonnet
- Internal travel stop
- Locking device
- CDSA sealing concept, see page 32
- Flexible diaphragm suspension
- Encapsulated diaphragm

### Optional

- Adjustable internal stroke limiter
- U-Lock for hand wheel
- Assembly of proximity switches

### Technical Data

|  |  |
|--|--|
| Control function:                              | Manually operated  |
| Max. working pressure:                         | 10 bar (150 psi)   |
| Max. working temperature:                      | 160°C (320°F) dependent on application   |
| Diaphragm material:                            | EPDM or PTFE   |
| Valve body material:                           | Forged 1.4435/ 316L ASME/BPE<br>Investment cast 1.4435/ 316L<br>Other Alloys                   |
| End connection:                                | Butt weld ends see fold out page 21<br>Clamps and flanges see page 22 to 24<br>Special ends    |
| Bonnets suitable for:                          | Two-Way bodies<br>Welded configurations<br>T- bodies<br>Multiport bodies<br>Tank bottom bodies |
| Flow rate:                                     | Kv in m <sup>3</sup> /h (Cv in GPM) see page 9   |
| Diaphragm size:                                | MA see table   |
| Technical data also valid for multiport valve. |  |

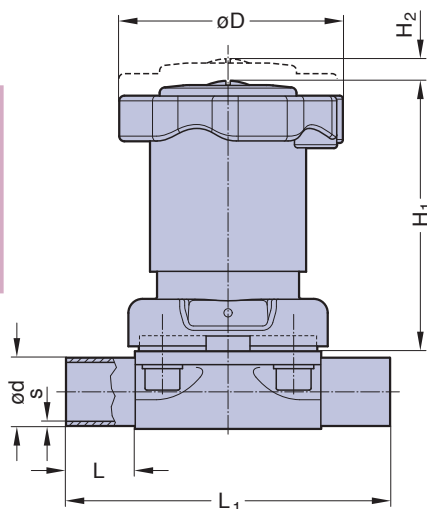

Butt weld ends  
MA 25 - 50  
Fold out page 21

| DN (mm) | MA | Dimensions (mm) |                |                |                |     | Total weight ca. (kg)<br>KMA 905 |        |
|---------|----|-----------------|----------------|----------------|----------------|-----|----------------------------------|--------|
|         |    | L               | L <sub>1</sub> | H <sub>1</sub> | H <sub>2</sub> | D   | Investment cast                  | Forged |
| 15-25   | 25 | 25              | 120            | 100            | 10             | 84  | 1,4                              | 1,6    |
| 32-40   | 40 | 25              | 153            | 119            | 16             | 112 | 2,8                              | 3,0    |
| 50      | 50 | 30              | 173            | 136            | 20             | 135 | 3,8                              | 4,6    |

Valve type overview see page 26 and 27.  
Ordering key see page 66 to 68.

## Manual Valve DN 65 - 100 mm (2 1/2" - 4")



DN 80, KMA 995

### Features

- **Stainless steel bonnet and plastic hand wheel**
- Non rising hand wheel with optical indicator
- Flexible diaphragm suspension
- Encapsulated diaphragm
- CDSA sealing concept, see page 32

### Optional

- Adjustable travel stop or stroke limiter
- Sealed bonnet
- Locking device

### Technical Data

|  |  |
|--|--|
| Control function:                              | Manually operated  |
| Max. working pressure:                         | EPDM 10 bar (150 psi)<br>PTFE 8 bar (115 psi)  |
| Max. working temperature:                      | 160°C (320°F) dependent on application   |
| Diaphragm material:                            | EPDM or PTFE   |
| Valve body material:                           | Forged 1.4435/ 316L ASME/BPE<br>Investment cast 1.4435/ 316L<br>Other Alloys                   |
| End connection:                                | Butt weld ends see fold out page 21<br>Clamps and flanges see page 22 to 24<br>Special ends    |
| Bonnets suitable for:                          | Two-Way bodies<br>Welded configurations<br>T- bodies<br>Multiport bodies<br>Tank bottom bodies |
| Flow rate:                                     | Kv in m <sup>3</sup> /h (Cv in GPM) see page 9   |
| Diaphragm size:                                | MA see table   |
| Technical data also valid for multiport valve. |  |

Butt weld ends  
MA 25 - 100  
Fold out page 21

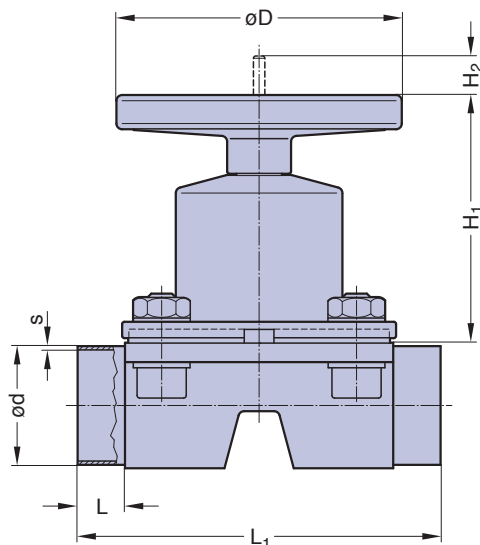

DN 65 - 100 (Drawing MA 80)

| DN<br>(mm) | MA  | Dimensions (mm) |                |                |                |     | Total weight ca. (kg) |        |
|------------|-----|-----------------|----------------|----------------|----------------|-----|-----------------------|--------|
|            |     | L               | L <sub>1</sub> | H <sub>1</sub> | H <sub>2</sub> | D   | Investment<br>cast    | Forged |
| 65         | 80  | 30              | 216            | 180            | 38             | 198 | 10,0                  | 13,0   |
| 80         | 80  | 30              | 254            | 180            | 38             | 198 | 10,0                  | 13,0   |
| 100        | 100 | 30              | 305            | 220            | 50             | 252 | 19,0                  | 17,0   |

Valve type overview see page 26 and 27.  
Ordering key see page 66 to 68.

## Pneumatically Operated Valve DN 4 - 15 mm (1/4" - 1/2")



Cf. 1, 2 & 3



Cf. 4, 5 & 6

Butt weld ends  
MA 8  
Fold out page 21

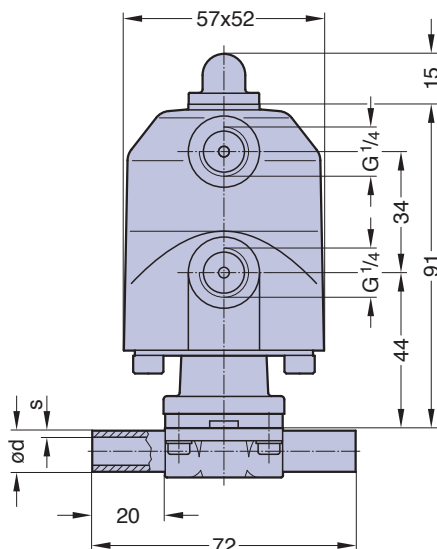

### Features

- Efficient plastic piston actuator with stainless steel distance piece
- Direction of control air connection is mountable in 90° rotations
- CDSA sealing concept, see page 32
- Flexible diaphragm suspension
- Optical indicator

### Optional

- Available with a wide range of control equipment and accessories see page 132 to 139, also for retrofitting

### Technical Data

- Control function (Cf.): Pneumatically operated  
 Fail safe close (NC): Cf. 1 & 4  
 Fail safe open (NO): Cf. 2 & 5  
 Double acting (DA): Cf. 3 & 6  
 At control function NO/DA higher control pressure than required may affect the lifetime of the working diaphragm.
- Direction  
 Control connection: At Cf. 1, 2 & 3, 90° to flow direction, standard  
 At Cf. 4, 5 & 6 in flow direction
- Max. working pressure: Unidirectional (delta p = 100%)  
 EPDM diaphragm 8 bar (115 psi)  
 PTFE diaphragm 7 bar (100 psi)

Higher working pressure may be achieved with different actuator. Please consult a SED factory representative for working pressure above the indicated maximum.

- Max. working temperature: 160°C (320°F) dependent on application
- Control pressure: Cf. 1 & 4 4 - 7 bar (60 - 100 psi)  
 Cf. 2, 3, 5 & 6 3,5 - 4,5 bar (50 - 65 psi)
- Diaphragm material: EPDM or PTFE
- Valve body material: Forged 1.4435/ 316 L ASME/BPE  
 Investment cast 1.4435/ 316 L  
 Other alloys
- End connection: Butt weld ends see fold out page 21  
 Clamps and flanges see page 22 to 24  
 Special ends
- Actuators suitable for: Two-Way bodies  
 Welded configurations  
 T-bodies  
 Multiport bodies  
 Tank bottom bodies
- Flow rate: Kv in m<sup>3</sup>/h (Cv in GPM) see page 9
- Diaphragm size: MA 8
- Weight: ca. 0,5 kg
- Technical data also valid for multiport valve.

| DN<br>(mm) | MA | Filling volume (NL) |       |
|------------|----|---------------------|-------|
|            |    | NC                  | NO/DA |
| 4-15       | 8  | 0,027               | 0,027 |

Valve type overview see page 26 and 27.  
 Ordering key see page 66 to 68.

## Pneumatically Operated Valve DN 8 - 20 mm (3/8" - 3/4")



Cf. 1, 2 & 3



Cf. 4 & 5

Butt weld ends  
MA 10  
Fold out page 21

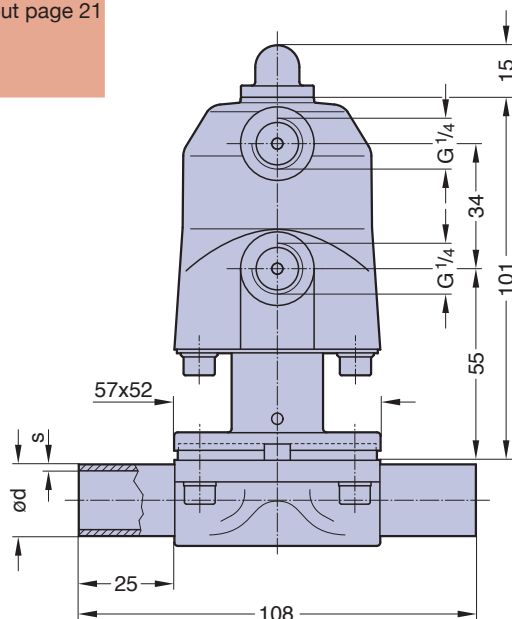

### Features

- Efficient plastic piston actuator with stainless steel distance piece
- Control air connection 90° to flow direction
- Flexible diaphragm suspension
- Encapsulated diaphragm
- Optical indicator
- Compact design, the outside diameter of the actuator is the same size as the bonnet flange
- CDSA sealing concept, see page 32

### Optional

- Available with a wide range of control equipment and accessories see page 132 to 139, also for retrofitting
- Control air connection in flow direction

### Technical Data

- Control function (Cf.): Pneumatically operated  
 Fail safe close (NC): Cf. 1 & 4  
 Fail safe open (NO): Cf. 2 & 5  
 Double acting (DA): Cf. 3  
 At control function NO/DA higher control pressure than required may affect the lifetime of the working diaphragm.
- Direction  
 Control connection:  
 Max. working pressure: At Cf. 1, 2 & 3, 90° to flow direction, standard Unidirectional (delta p = 100%)  
 EPDM diaphragm 8 bar (115 psi)  
 PTFE diaphragm 7 bar (100 psi)

Higher working pressure may be achieved with different actuator. Please consult a SED factory representative for working pressure above the indicated maximum.

- Max. working temperature:  
 Control pressure: 160°C (320°F) dependent on application  
 Cf. 1 4,2 - 7 bar (60 - 100 psi)  
 Diaphragm material: Cf. 2, 3 4 - 5 bar (60 - 72 psi)  
 Valve body material: EPDM or PTFE  
 Forged 1.4435/ 316 L ASME/BPE  
 Investment cast 1.4435/ 316 L
- End connection: Other alloys  
 Butt weld ends see fold out page 21  
 Clamps and flanges see page 22 to 24
- Actuators suitable for: Special ends  
 Two-Way bodies  
 Welded configurations  
 T-bodies  
 Multiport bodies  
 Tank bottom bodies
- Flow rate: Tank bottom bodies  
 Diaphragm size: Kv in m<sup>3</sup>/h (Cv in GPM) see page 9  
 Weight: MA 10  
 ca. 0,8 kg
- Technical data also valid for multiport valve.

| DN<br>(mm) | MA | Filling volume (NL) |       |
|------------|----|---------------------|-------|
|            |    | NC                  | NO/DA |
| 8-20       | 10 | 0,027               | 0,027 |

Valve type overview see page 26 and 27.  
 Ordering key see page 66 to 68.



## Pneumatically Operated Valve DN 15 - 50 mm (3/4" - 2 1/2")



Cf. 4, 5 & 6

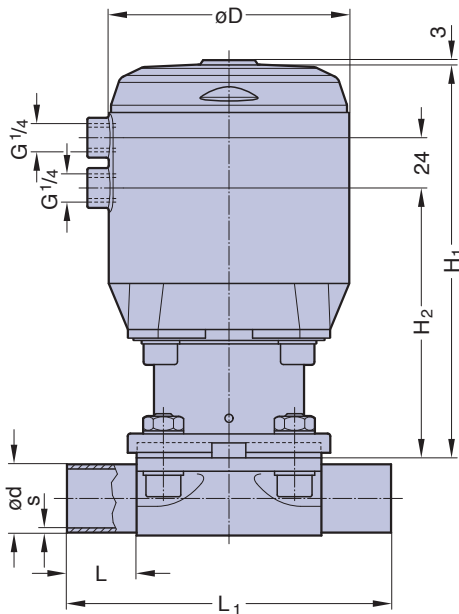

Butt weld ends  
MA 25 - 50  
Fold out page 21

### Features

- Plastic piston actuator with stainless steel distance piece
- Compact design
- Control air connection in flow direction
- CDSA sealing concept, see page 32
- Flexible diaphragm suspension
- Encapsulated diaphragm

### Optional

- Available with a wide range of control equipment and accessories see page 132 to 139, also for retrofitting
- Control air connection 90° to flow direction

### Technical Data

- Control function (Cf.): Pneumatically operated  
 Fail safe close (NC): Cf. 1 & 4  
 Fail safe open (NO): Cf. 2 & 5  
 Double acting (DA): Cf. 3 & 6  
 At control function NO/DA higher control pressure than required may affect the lifetime of the working diaphragm.
- Direction  
 Control connection: At Cf. 4, 5 & 6, in flow direction, standard  
 At Cf. 1, 2 & 3, 90° to flow direction
- Max. working pressure: Unidirectional ( $\Delta p = 100\%$ )  
 EPDM Diaphragm 10 bar (150 psi)  
 PTFE Diaphragm 8 bar (115 psi)
- Higher working pressure may be achieved with different actuator. Please consult a SED factory representative for working pressure above the indicated maximum.
- Max. working temperature: 160°C (320°F) dependent on application
- Control pressure:  
 Cf. 1 & 4 4,5 - 7 bar (65 - 100 psi)  
 Cf. 2, 3, 5 & 6 4 - 5 bar (60 - 72 psi)
- Diaphragm material: EPDM or PTFE  
 Valve body material: Forged 1.4435/ 316 L ASME/BPE  
 Investment cast 1.4435/ 316 L  
 Other alloys
- End connection: Butt weld ends see fold out page 21  
 Clamps and flanges see page 22 to 24  
 Special ends
- Actuators suitable for: Two-Way bodies  
 Welded configurations  
 T-bodies  
 Multiport bodies  
 Tank bottom bodies
- Flow rate: Kv in m<sup>3</sup>/h (Cv in GPM) see page 9  
 Diaphragm size: MA see table below  
 Technical data also valid for multiport valve.

| DN<br>(mm) | MA | Dimensions (mm) |                |                |                |     | Total weight ca. (kg) |        | Filling volume (NL) |       |
|------------|----|-----------------|----------------|----------------|----------------|-----|-----------------------|--------|---------------------|-------|
|            |    | L               | L <sub>1</sub> | H <sub>1</sub> | H <sub>2</sub> | D   | Investment cast       | Forged | NC                  | NO/DA |
| 15-25      | 25 | 25              | 120            | 160            | 107            | 95  | 1,9                   | 2,0    | 0,17                | 0,20  |
| 32-40      | 40 | 25              | 153            | 190            | 129            | 115 | 3,9                   | 4,2    | 0,31                | 0,34  |
| 50         | 50 | 30              | 173            | 236            | 171            | 144 | 7,0                   | 8,0    | 0,68                | 0,80  |

Valve type overview see page 26 and 27.  
 Ordering key see page 66 to 68.

## Pneumatically Operated Valve DN 15 - 100 mm (3/4" - 4")



Cf. 1

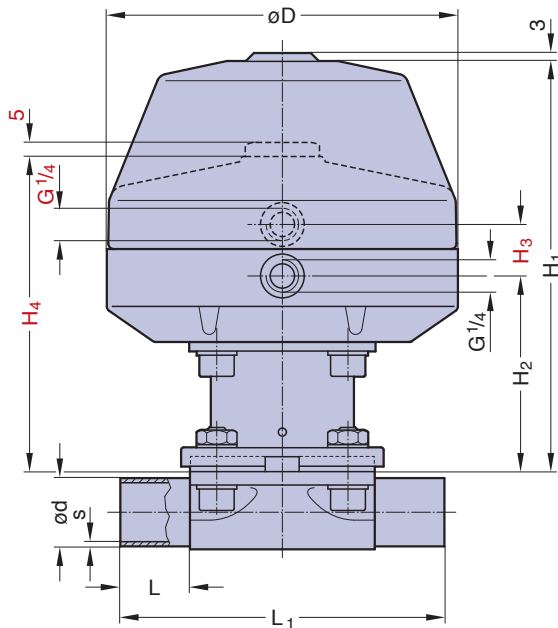

Butt weld ends  
MA 25 - 100  
Fold out page 21

### Features

- Plastic diaphragm actuator with stainless steel distance piece
- Control air connection 90° to flow direction
- Flexible diaphragm suspension
- Encapsulated diaphragm
- CDSA sealing concept, see page 32

### Optional

- Available with a wide range of control equipment and accessories see page 132 to 139, also for retrofitting

### Technical Data

Control function (Cf.): Pneumatically operated  
 Fail safe close (NC): Cf. 1  
 Fail safe open (NO): Cf. 2  
 Double acting (DA): Cf. 3  
 At control function NO/DA higher control pressure than required may affect the lifetime of the working diaphragm.

### Direction

Control connection: At Cf. 1, 2 & 3, 90° to flow direction, standard  
 Max. working pressure: Unidirectional (delta p = 100%)

| Diaphragm | DN 15-50 (1/2"-2") | DN 65-80 (2,5"-3") | DN 100 (4")    |
|-----------|--------------------|--------------------|----------------|
| EPDM      | 10 bar (150 psi)   | 7 bar (100 psi)    | 6 bar (87 psi) |
| PTFE      | 8 bar (115 psi)    | 6 bar (87 psi)     | 5 bar (72 psi) |

Higher working pressure may be achieved with different actuator. Please consult a SED factory representative for working pressure above the indicated maximum.

Max. working temperature: 160°C (320°F) dependent on application

Control pressure:  
 Cf. 1 DN 15-50 4,5 - 6 bar (65-87 psi)  
 Cf. 1 DN 65-80 4,5 - 7 bar (65-100 psi)  
 Cf. 1 DN 100 5,5 - 7 bar (80-100 psi)  
 Cf. 2 & 3 DN 15-80 4 - 5,5 bar (60-80 psi)  
 Cf. 2 & 3 DN 100 5 - 6,5 bar (72-93 psi)

Diaphragm material: EPDM or PTFE  
 Valve body material: Forged 1.4435/ 316 L ASME/BPE  
 Investment cast 1.4435/ 316 L  
 Other alloys  
 End connection: Butt weld ends see fold out page 21  
 Clamps and flanges see page 22 to 24  
 Special ends

Actuators suitable for: Two-Way bodies  
 Welded configurations  
 T-bodies  
 Multiport bodies  
 Tank bottom bodies

Flow rate: Kv in m<sup>3</sup>/h (Cv in GPM) see page 9

Diaphragm size: MA see table below

Technical data also valid for multiport valve.

| DN (mm) | MA  | Dimensions (mm) |                |                |                |                |                | D   | Total weight ca. (kg) |        | Filling volume (NL) |       |
|---------|-----|-----------------|----------------|----------------|----------------|----------------|----------------|-----|-----------------------|--------|---------------------|-------|
|         |     | L               | L <sub>1</sub> | H <sub>1</sub> | H <sub>2</sub> | H <sub>3</sub> | H <sub>4</sub> |     | Investment cast       | Forged | NC                  | NO/DA |
| 15-25   | 25  | 25              | 120            | 148            | 71             | 31             | 120            | 130 | 1,9                   | 2,0    | 0,15                | 0,11  |
| 32-40   | 40  | 25              | 153            | 194            | 95             | 31             | 144            | 161 | 4,7                   | 4,9    | 0,26                | 0,23  |
| 50      | 50  | 30              | 173            | 233            | 109            | 31             | 177            | 217 | 7,0                   | 8,0    | 0,73                | 0,54  |
| 65      | 80  | 30              | 216            | 314            | 166            | 41             | 275            | 265 | 20,0                  | 23,0   | 2,30                | 1,87  |
| 80      | 80  | 30              | 254            | 314            | 166            | 41             | 275            | 265 | 20,0                  | 23,0   | 2,30                | 1,87  |
| 100     | 100 | 30              | 305            | 314            | 166            | 41             | 284            | 265 | 29,0                  | 27,0   | 2,30                | 2,00  |

Note: H<sub>3</sub> and H<sub>4</sub> only for valves with Cf. 2 and Cf. 3 H<sub>1</sub> only for valve with Cf. 1

Valve type overview see page 26 and 27.  
 Ordering key see page 66 to 68.



## Manual Valve DN 8 - 20 mm (3/8" - 3/4")



### Features

- Plastic bonnet and hand wheel
- Rising hand wheel
- Sealed bonnet with optical indicator
- Adjustable internal travel stop
- CDSA sealing concept, see page 32
- Flexible diaphragm suspension
- Encapsulated diaphragm

### Technical Data

|  |  |
|--|--|
| Control function:                              | Manually operated  |
| Max. working pressure:                         | 6 bar (87 psi)   |
| Max. working temperature:                      | S-Version: 80°C (176°F)<br>dependent on application<br>HS-Version: 150°C (300°F)<br>dependent on application |
| Diaphragm material:                            | EPDM or PTFE   |
| Body material:                                 | Forged 1.4435/ 316L ASME/BPE<br>Investment cast 1.4435/ 316L<br>Other Alloys                                 |
| End connection:                                | Butt weld ends see fold out page 21<br>Clamps and flanges see page 22 to 24<br>Special ends                  |
| Bonnets suitable for:                          | Two-Way bodies / Welded configurations<br>T- bodies / Multiport bodies<br>Tank bottom bodies                 |
| Flow rate:                                     | Kv in m <sup>3</sup> /h (Cv in GPM) see page 9   |
| Diaphragm size:                                | MA 10  |
| Weight:  | ca. 0,5 kg   |
| Technical data also valid for multiport valve. |  |

Butt weld ends  
MA 10  
Fold out page 21

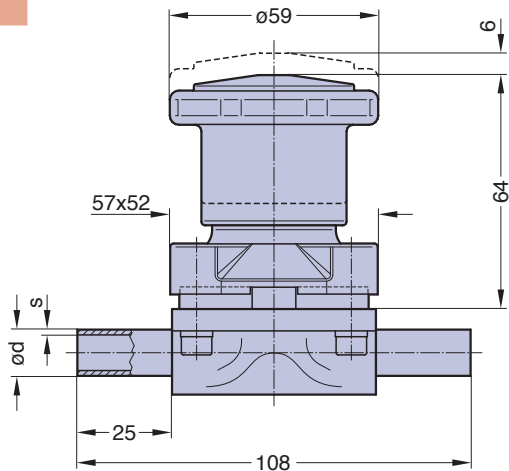

Valve type overview see page 26 and 27.  
Ordering key see page 66 to 68.

## Manual Valve DN 15 - 50 mm (3/4" - 2 1/2")



### Features

- Plastic bonnet and plastic hand wheel
- Non rising hand wheel with optical indicator
- Flexible diaphragm suspension
- Encapsulated diaphragm
- CDSA sealing concept, see page 32
- Locking device

The system can be engaged by simply lifting the handwheel once the required position has been reached.

To release the operating mechanism, simply return the handwheel to its previous position by pushing it downwards.

When the system is in the locked position, u-lock can be installed to protect the plant against unwanted interference.

### Optional

- Adjustable stroke limiter on top

### Technical Data

|                           |   |
|---------------------------|---|
| Control function:         | Manually operated   |
| Max. working pressure:    | 10 bar (150 psi)  |
| Max. working temperature: | 80°C (176°F)  |
| Diaphragm material:       | dependent on application<br>EPDM or PTFE  |
| Valve body material:      | Forged 1.4435/ 316L ASME/BPE<br>Investment cast 1.4435/ 316L<br>Other Alloys                |
| End connection:           | Butt weld ends see fold out page 21<br>Clamps and flanges see page 22 to 24<br>Special ends |
| Suitable for:             | Two-Way bodies,<br>otherwise depending on design  |
| Flow rate:                | Kv in m <sup>3</sup> /h (Cv in GPM) see page 9  |
| Diaphragm size:           | MA see table  |

Butt weld ends  
MA 25 - 50  
Fold out page 21

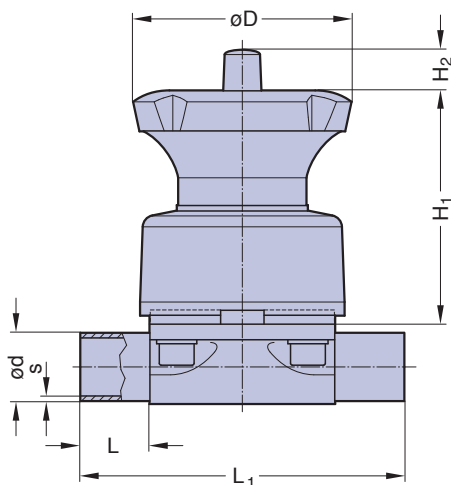

| DN<br>(mm) | MA | Dimensions (mm) |                |                |                |     | Total weight ca. (kg) |        |
|------------|----|-----------------|----------------|----------------|----------------|-----|-----------------------|--------|
|            |    | L               | L <sub>1</sub> | H <sub>1</sub> | H <sub>2</sub> | D   | Investment cast       | Forged |
| 15-25      | 25 | 25              | 120            | 85             | 15             | 154 | 0,87                  | 0,96   |
| 32-40      | 40 | 25              | 153            | 102            | 24             | 194 | 1,59                  | 1,83   |
| 50         | 50 | 30              | 173            | 117            | 24             | 224 | 2,30                  | 3,40   |

Valve type overview see page 26 and 27.  
Ordering key see page 66 to 68.

## Manual Valve DN 65 - 100 mm (2 1/2" - 4")



DN 100, KMD 985

### Features

- Plastic bonnet and plastic hand wheel
- Non rising hand wheel with optical indicator
- Flexible diaphragm suspension
- Encapsulated diaphragm
- CDSA sealing concept, see page 32

### Optional

- Adjustable travel stop or stroke limiter on top
- Sealed bonnet
- Locking device

### Technical Data

|                           |  |
|---------------------------|--|
| Control function:         | Manually operated  |
| Max. working pressure:    | EPDM 10 bar (150 psi)<br>PTFE 8 bar (115 psi)  |
| Max. working temperature: | S-Version 80°C (176°F)<br>dependent on application   |
| Diaphragm material:       | EPDM or PTFE   |
| Valve body material:      | Forged 1.4435/ 316L ASME/BPE<br>Investment cast 1.4435/ 316L<br>Other Alloys                   |
| End connection:           | Butt weld ends see fold out page 21<br>Clamps and flanges see page 22 to 24<br>Special ends    |
| Suitable for:             | Two-Way bodies<br>Welded configurations<br>T- bodies<br>Multiport bodies<br>Tank bottom bodies |
| Flow rate:                | Kv in m <sup>3</sup> /h (Cv in GPM) see page 9   |
| Diaphragm size:           | MA see table   |

Butt weld ends  
MA 25 - 100  
Fold out page 21

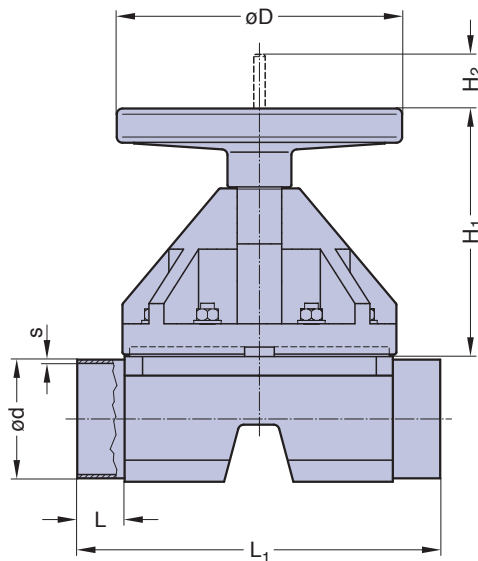

DN 65 - 100 (Drawing MA 100)

| DN<br>(mm) | MA  | Dimensions (mm) |                |                |                |     | Total weight ca. (kg) |        |
|------------|-----|-----------------|----------------|----------------|----------------|-----|-----------------------|--------|
|            |     | L               | L <sub>1</sub> | H <sub>1</sub> | H <sub>2</sub> | D   | Investment<br>cast    | Forged |
| 65         | 80  | 30              | 216            | 180            | 38             | 198 | 7,0                   | 9,0    |
| 80         | 80  | 30              | 254            | 180            | 38             | 198 | 7,0                   | 9,0    |
| 100        | 100 | 30              | 305            | 220            | 50             | 252 | 14,0                  | 12,0   |

Valve type overview see page 26 and 27.  
Ordering key see page 66 to 68.

## Pneumatically Operated Valve DN 8 - 20 mm (3/8" - 3/4")



HS-Version, Cf. 1, 2 & 3



HS-Version, Cf. 4 & 5

Butt weld ends  
MA 10  
Fold out page 21

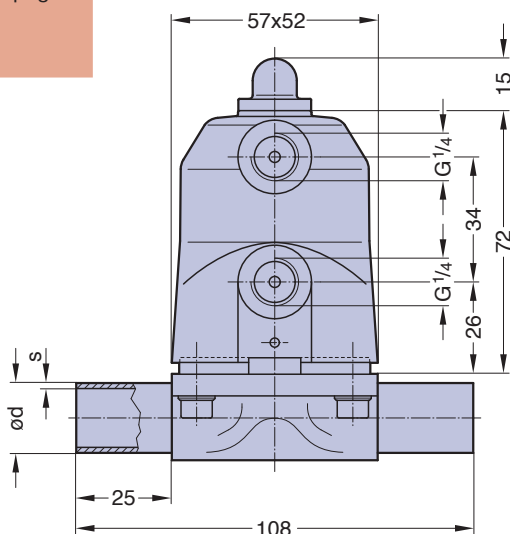

### Features

- Efficient plastic piston actuator direct assembled with the valve body
- Control air connection 90° to flow direction for side by side or other installations saving space
- Compact design, the outside diameter of the actuator is the same size as the bonnet flange
- Actuator high resistance to heat transfer
- Smooth exterior design ideal for wash downs
- Encapsulated diaphragm
- Optical indicator
- CDSA sealing concept, see page 32

### Optional

- Available with a wide range of control equipment and accessories see page 132 to 139, also for retrofitting
- Control air connection in flow direction

### Technical Data

- Control function (Cf.): Pneumatically operated  
 Fail safe close (NC): Cf. 1 & 4  
 Fail safe open (NO): Cf. 2 & 5  
 Double acting (DA): Cf. 3  
 At control function NO/DA higher control pressure than required may affect the lifetime of the working diaphragm.
- Direction  
 Control connection: At Cf. 1, 2 & 3, 90° to flow direction, standard  
 At Cf. 4 & 5 in flow direction
- Max. working pressure: Unidirectional ( $\Delta p = 100\%$ )  
 EPDM diaphragm 8 bar (115 psi)  
 PTFE diaphragm 7 bar (100 psi)

Higher working pressure may be achieved with different actuator. Please consult a SED factory representative for working pressure above the indicated maximum.

- Max. working temperature: PS-Version 80°C (176°F)  
 HS-Version 150°C (300°F)  
 dependent on Application
- Control pressure: Cf. 1 & 4 4,2 - 7 bar (60 - 100 psi)  
 Cf. 2, 3 & 5 4 - 5 bar (60 - 72 psi)
- Diaphragm material: EPDM or PTFE
- Valve body material: Forged 1.4435/ 316 L ASME/BPE  
 Investment cast 1.4435/ 316 L  
 Other alloys
- End connection: Butt weld ends see fold out page 21  
 Clamps and flanges see page 22 to 24  
 Special ends
- Actuators suitable for: Two-Way bodies  
 Welded configurations
- Flow rate: Kv in m<sup>3</sup>/h (Cv in GPM) see page 9
- Diaphragm size: MA 10
- Weight: ca. 0,6 kg

| DN<br>(mm) | MA | Filling volume (NL) |       |
|------------|----|---------------------|-------|
|            |    | NC                  | NO/DA |
| 8-20       | 10 | 0,027               | 0,027 |

Valve type overview see page 26 and 27.  
 Ordering key see page 66 to 68.

## Pneumatically Operated Valve DN 15 - 50 mm (3/4" - 2 1/2")



Cf. 4, 5 & 6

### Features

- Plastic piston actuator
- Compact design
- Actuator high resistance to heat transfer
- Control air connection in flow direction
- CDSA sealing concept, see page 32
- Flexible diaphragm suspension
- Encapsulated diaphragm
- Smooth exterior design ideal for wash downs

### Optional

- Available with a wide range of control equipment and accessories see page 132 to 139, also for retrofitting
- Control air connection 90° to flow direction

### Technical Data

- Control function (Cf.): Pneumatically operated  
 Fail safe close (NC): Cf. 1 & 4  
 Fail safe open (NO): Cf. 2 & 5  
 Double acting (DA): Cf. 3 & 6  
 At control function NO/DA higher control pressure than required may affect the lifetime of the working diaphragm.
- Direction  
 Control connection: At Cf. 4, 5 & 6, in flow direction, standard  
 At Cf. 1, 2 & 3, 90° to flow direction
- Max. working pressure: Unidirectional (delta p = 100%)  
 EPDM Diaphragm 10 bar (150 psi)  
 PTFE Diaphragm 8 bar (115 psi)
- Higher working pressure may be achieved with different actuator. Please consult a SED factory representative for working pressure above the indicated maximum.
- Max. working temperature: HS-Version 150°C (300°F)  
 dependent on application
- Control pressure: Cf. 1 & 4 4,5 - 7 bar (65 - 100 psi)  
 Cf. 2, 3, 5 & 6 4 - 5 bar (60 - 72 psi)
- Diaphragm material: EPDM or PTFE  
 Valve body material: Forged 1.4435/ 316 L ASME/BPE  
 Investment cast 1.4435/ 316 L  
 Other alloys
- End connection: Butt weld ends see fold out page 21  
 Clamps and flanges see page 22 to 24  
 Special ends
- Actuators suitable for: Two-Way bodies  
 Welded configurations
- Flow rate: Kv in m³/h (Cv in GPM) see page 9  
 Diaphragm size: MA see table below

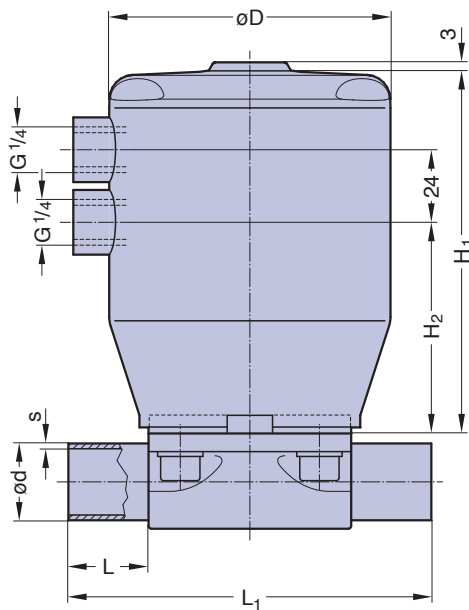

Cf. 4, 5 & 6

Butt weld ends  
 MA 25 - 50  
 Fold out page 21

| DN<br>(mm) | MA | Dimensions (mm) |                |                |                |     | Total weight ca. (kg) |        | Filling volume (NL) |       |
|------------|----|-----------------|----------------|----------------|----------------|-----|-----------------------|--------|---------------------|-------|
|            |    | L               | L <sub>1</sub> | H <sub>1</sub> | H <sub>2</sub> | D   | Investment cast       | Forged | NC                  | NO/DA |
| 15-25      | 25 | 25              | 120            | 120            | 70             | 95  | 1,5                   | 1,6    | 0,17                | 0,20  |
| 32-40      | 40 | 25              | 153            | 133            | 75             | 115 | 2,8                   | 3,1    | 0,31                | 0,34  |
| 50         | 50 | 30              | 173            | 173            | 111            | 144 | 4,9                   | 6,0    | 0,68                | 0,80  |

Valve type overview see page 26 and 27.  
 Ordering key see page 66 to 68.



## Pneumatically Operated Valve DN 15 - 80 mm (3/4" - 3")



Cf. 1

### Features

- Plastic diaphragm actuator direct assembled with the valve body
- Actuator high resistance to heat transfer
- Smooth exterior design ideal for wash downs
- Control air connection 90° to flow direction
- Flexible diaphragm suspension
- Encapsulated diaphragm
- CDSA sealing concept, see page 32

### Optional

- Available with a wide range of control equipment and accessories see page 132 to 139, also for retrofitting

### Technical Data

Control function (Cf.): Pneumatically operated  
 Fail safe close (NC): Cf. 1  
 Fail safe open (NO): Cf. 2  
 Double acting (DA): Cf. 3  
 At control function NO/DA higher control pressure than required may affect the lifetime of the working diaphragm.

#### Direction

Control connection: At Cf. 1, 2 & 3, 90° to flow direction, standard  
 Max. working pressure: Unidirectional ( $\Delta p = 100\%$ )

| Diaphragm | DN 15-50 (1/2"-2") | DN 65-80 (2,5"-3") |
|-----------|--------------------|--------------------|
| EPDM      | 10 bar (150 psi)   | 7 bar (100 psi)    |
| PTFE      | 8 bar (115 psi)    | 6 bar (87 psi)     |

Higher working pressure may be achieved with different actuator. Please consult a SED factory representative for working pressure above the indicated maximum.

Max. working temperature: S-Version 80°C (176°F)

Control pressure:  
 Cf. 1 DN 15-50 4,5 - 6 bar (65-87 psi)  
 Cf. 1 DN 65-80 4,5 - 7 bar (65-100 psi)  
 Cf. 2 & 3 DN 15-80 4 - 5,5 bar (60-80 psi)

Diaphragm material: EPDM or PTFE  
 Valve body material: Forged 1.4435/ 316 L ASME/BPE  
 Investment cast 1.4435/ 316 L  
 Other alloys

End connection: Butt weld ends see fold out page 21  
 Clamps and flanges see page 22 to 24  
 Special ends

Actuators suitable for: Two-Way bodies  
 Welded configurations

Flow rate: Kv in m<sup>3</sup>/h (Cv in GPM) see page 9  
 Diaphragm size: MA see table below

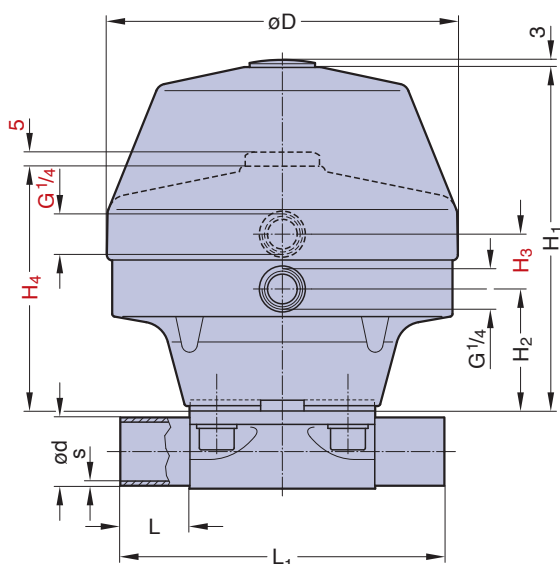

Butt weld ends  
 MA 25 - 80  
 Fold out page 21

| DN (mm) | MA | Dimensions (mm) |                |                |                |                |                |                 | D    | Total weight ca. (kg) |      | Filling volume (NL) |  |
|---------|----|-----------------|----------------|----------------|----------------|----------------|----------------|-----------------|------|-----------------------|------|---------------------|--|
|         |    | L               | L <sub>1</sub> | H <sub>1</sub> | H <sub>2</sub> | H <sub>3</sub> | H <sub>4</sub> | Investment cast |      | Forged                | NC   | NO/DA               |  |
| 15-25   | 25 | 25              | 120            | 128            | 49             | 31             | 97             | 130             | 1,9  | 2,0                   | 0,16 | 0,13                |  |
| 32-40   | 40 | 25              | 153            | 176            | 77             | 31             | 131            | 161             | 3,8  | 4,1                   | 0,36 | 0,28                |  |
| 50      | 50 | 30              | 173            | 214            | 91             | 31             | 161            | 217             | 8,0  | 9,0                   | 1,15 | 0,50                |  |
| 65      | 80 | 30              | 216            | 269            | 121            | 41             | 229            | 265             | 16,0 | 18,0                  | 1,15 | 0,50                |  |
| 80      | 80 | 30              | 254            | 269            | 121            | 41             | 229            | 265             | 16,0 | 18,0                  | 1,15 | 0,50                |  |

Note: H<sub>3</sub> and H<sub>4</sub> only for valves with Cf. 2 and Cf. 3 H<sub>1</sub> only for valve with Cf. 1

Valve type overview see page 26 and 27.  
 Ordering key see page 66 to 68.



# Ordering key

|      |      |                     |                           |                    |                           |               |                                       |          |
|------|------|---------------------|---------------------------|--------------------|---------------------------|---------------|---------------------------------------|----------|
| 1    | 2    | 3                   | 4                         | 5                  | 6.1                       | 6.2           | 7                                     | 8        |
| Type | Size | Valve body material | Valve body end connection | Diaphragm material | Actuator control function | Actuator type | Surface roughness of the bodies in Ra | QR-/RFID |

| Pos. | Description   | Code   | Specification   |
|------|---|--|---|
| 1    | <b>Type:</b><br><br>See page 34 - 65  | 217, 317, 407, 417<br>206, 397, 907, 997<br>394, 592<br>190, 195, 395, 495<br>205, 295, 905, 995<br>188, 385, 402<br>289, 982, 985               | Steripur Series, stainless steel actuator, pneumatic<br>Steripur Series, stainless steel actuator, manual<br>Steripur Series, two stage stainless steel actuator, pneumatic<br>KMA Series, actuator with stainless steel adaptation, pneumatic<br>KMA Series, actuator with stainless steel adaptation, manual<br>KMD Series, plastic actuator direct mounted, pneumatic<br>KMD Series, plastic actuator direct mounted, manual   |
| 2    | <b>Size:</b> See page: 21   | 04 - 100   | DN 4, 6, 8, 10, 15, 20, 25, 32, 40, 50, 65, 80, 100   |
| 3    | <b>Valve body material:</b><br><br>See page: 20   | 7<br>77<br>78<br>20  | Stainless steel, investment cast 1.4435/S31603, ASME BPE Table MM-2.1-1<br>Stainless steel, forged 1.4435/S31603, ASME BPE Table MM-2.1-1<br>Stainless steel, forged 1.4435/S31603 Fe < 0,5%<br>Hastelloy, C-22 2.4602  |
| 4    | <b>Valve body end connections:</b><br>(bolt letters most common versions)<br><br><b>Valve body end connection for assembly:</b><br><br>See page 21 - 24 | 39<br><b>40</b><br>41<br><b>42</b><br><b>45</b><br>49<br>94<br>95<br>97<br>98<br><br>640<br>642<br>645<br>649<br>545<br>842<br>442<br>342<br>242 | Butt weld end acc. DIN<br><b>Butt weld end acc. EN ISO 1127 (DIN 11866 Series B)</b><br>Butt weld end acc. DIN 11850 Series 1<br><b>Butt weld end acc. DIN 11850 Series 2 (DIN 11866 Series A)</b><br><b>Butt weld end acc. ASME BPE MFS length (DIN 11866 Series C)</b><br>Butt weld end acc. SMS 3008<br>Butt weld end acc. BS 4825 R1<br>Butt weld end acc. to ASME BPE Table DT-4.1-1 Tangent Length<br>Butt weld end acc. JIS G 3447<br>Butt weld end acc. JIS G 3459<br><b>First digit stands for the end connection and last two digits for the tube standard</b><br>Clamp ISO 1127, for tube EN ISO 1127, face to face DIN EN 558-1, Series 7<br>Clamp DIN 32676, for tube DIN 11850, face to face DIN EN 558-1, Series 7<br>Clamp ASME BPE, for tube ASME BPE, face to face DIN EN 558-1, Series 7<br>Clamp SMS 3017, for tube SMS 3008, face to face DIN EN 558-1, Series 7<br>Clamp ASME BPE, for tube ASME BPE, face to face ASME BPE Table DT-4.4.1-1<br>Aseptic Union DIN 11851, for tube DIN 11850 series 2 double-sided threaded spigot<br>Aseptic Union DIN 11864-1-A, for tube DIN 11850 series 2 double-sided threaded spigot<br>Aseptic flange DIN 11864-2-A, for tube DIN 11850 series 2, double-sided grooved<br>Aseptic clamp DIN 11864-3-A, for tube DIN 11850 series 2, double-sided grooved |
| 5    | <b>Diaphragm material:</b><br>(Other diaphragm materials on request)<br><br>See page 14 - 19  | 28<br>20<br>30<br>51<br>44   | EPDM, FDA / USP compliant MA 8 -100<br>EPDM, FDA / USP compliant MA 8 -100, preferred for SIP applications<br>PTFE(TFM) / EPDM one-piece, FDA / USP compliant, MA 25, 40, 50<br>PTFE(TFM) / EPDM one-piece, FDA / USP compliant, MA 8, MA 10<br>PTFE(TFM) / EPDM two-piece, FDA / USP compliant, MA 25 to MA 100  |
| 6.1  | <b>Actuator control function (Cf.) and orientation air inlet connection:</b><br><br>See page 34 - 65  | 1<br>2<br>3<br>4<br>5<br>6   | Manually operated<br>Normally closed (NC), orientation 90° to flow direction<br>Normally open (NO), orientation 90° to flow direction<br>Double-acting (DA), orientation 90° to flow direction<br>Normally closed (NC), orientation in flow direction<br>Normally open (NO), orientation in flow direction<br>Double-acting (DA), orientation in flow direction   |
| 6.2  | <b>Actuator type:</b><br><br>See page 34 - 46   | 25<br>30<br>45<br>70<br>100<br>170<br>T<br>T01<br>T02<br>T03<br><br>T11<br>T12<br>T 13   | Steripur, actuator size 25<br>Steripur, actuator size 30<br>Steripur, actuator size 45<br>Steripur, actuator size 70<br>Steripur, actuator size 100<br>Steripur, actuator size 170<br>Steripur, manually operated<br>Steripur, manually operated, incl. seal adjuster and locking device, Bonnet assembly bottom entry bolting<br>Steripur, manually operated, incl. seal adjuster, locking device and stroke limiter, Bonnet assembly bottom entry bolting<br>Steripur, manually operated, incl. seal adjuster, Bonnet assembly bottom entry bolting<br><br>Steripur, manually operated, incl. seal adjuster and locking device, Bonnet assembly through bolting<br>Steripur, manually operated, incl. seal adjuster, locking device and stroke limiter, Bonnet assembly through bolting<br>Steripur, manually operated, incl. seal adjuster, Bonnet assembly through bolting  |

# Ordering key



|      |      |                     |                           |                    |                           |               |                                       |          |
|------|------|---------------------|---------------------------|--------------------|---------------------------|---------------|---------------------------------------|----------|
| 1    | 2    | 3                   | 4                         | 5                  | 6.1                       | 6.2           | 7                                     | 8        |
| Type | Size | Valve body material | Valve body end connection | Diaphragm material | Actuator control function | Actuator type | Surface roughness of the bodies in Ra | QR-/RFID |

| Pos. | Description  | Code | Specification  |
|------|--|------|--|
| 6.2  | <b>Actuator type:</b><br><br>See page 48 - 65  | S    | KMD, Type 289, 385, 402, 982, 985 max. 80°C  |
|      |  | PS   | KMD, Type 188 max 80°C   |
|      |  | HS   | KMD for steam sterilizing up to max. 150°C   |
|      |  | AS   | KMA  |
|      |  | S01  | KMA, manually operated, incl. seal adjuster and locking device, Bonnet assembly bottom entry bolting                 |
|      |  | S02  | KMA, manually operated, incl. seal adjuster, locking device and stroke limiter, Bonnet assembly bottom entry bolting |
|      |  | S03  | KMA, manually operated, incl. seal adjuster, Bonnet assembly bottom entry bolting                                    |
|      |  | S11  | KMA, manually operated, incl. seal adjuster and locking device, Bonnet assembly through bolting                      |
|      |  | S12  | KMA, manually operated, incl. seal adjuster, locking device and stroke limiter, Bonnet assembly through bolting      |
|      |  | S13  | KMA, manually operated, incl. seal adjuster, Bonnet assembly through bolting   |
| 7    | <b>Surface roughness of the bodies in Ra: (µm)</b><br>Optional surface code SF 1-6 for spigot end (Pos. 4) code 45 or 95 only.<br><br>See page 10 - 11 | 02   | Internal mechanically polished Ra ≤ 0,8 µm   |
|      |  | 03   | Internal mechanically polished Ra ≤ 0,8 µm + Electropolished   |
|      |  | 07   | Internal mechanically polished Ra ≤ 0,6 µm   |
|      |  | 08   | Internal mechanically polished Ra ≤ 0,6 µm + Electropolished   |
|      |  | 09   | Internal mechanically polished Ra ≤ 0,4 µm   |
|      |  | 10   | Internal mechanically polished Ra ≤ 0,4 µm + Electropolished   |
|      |  | 14   | Inside mechanically polished Ra ≤ 0,25 µm  |
|      |  | 16   | Inside mechanically polished Ra ≤ 0,25 µm + Electropolished  |
|      |  | SF0  | No Finish Requirement  |
|      |  | SF1  | ASME BPE Table SF-2.4-1 Internal mechanically polished Ra ≤ 0,51 µm (20 µ-inch)                                      |
|      |  | SF2  | ASME BPE Table SF-2.4-1 Internal mechanically polished Ra ≤ 0,64 µm (25 µ-inch)                                      |
|      |  | SF3  | ASME BPE Table SF-2.4-1 Internal mechanically polished Ra ≤ 0,76 µm (30 µ-inch)                                      |
|      |  | SF4  | ASME BPE Table SF-2.4-1<br>Internal mechanically polished Ra ≤ 0,38 µm (15 µ-inch) + Electropolished                 |
| SF5  | ASME BPE Table SF-2.4-1<br>Internal mechanically polished Ra ≤ 0,51 µm (20 µ-inch) + Electropolished   |      |  |
| SF6  | ASME BPE Table SF-2.4-1<br>Internal mechanically polished Ra ≤ 0,64 µm (25 µ-inch) + Electropolished   |      |  |
| 8    | <b>QR-Code / RFID:</b>   | ID   | Diaphragm including RFID. Valve body respectively actuator including laser etched QR-Code.                           |
| 9    | <b>S-Number:</b>   | S... | To specify customized design and all the details for multipoint valves   |

Preferred standards bold. Visit our website (Configurator) to specify the right product for your application

# Ordering Example

|                             |   |            |   |            |   |            |   |            |
|-----------------------------|---|------------|---|------------|---|------------|---|------------|
| Position:                   | <b>1</b>  | <b>2</b>   | <b>3</b>  | <b>4</b>   | <b>5</b>  | <b>6.1</b> | <b>6.2</b>  | <b>7</b>   |
| Article Code:               | <b>4 9 5</b>  | <b>2 5</b> | <b>7 7</b>  | <b>4 2</b> | <b>2 8</b>  | <b>1</b>   | <b>AS</b>   | <b>0 3</b> |
| <b>Type:</b>                | 495<br>KMA Series<br>actuator with stainless<br>steel adaption<br>pneumatic |            |   |            |   |            | <b>Surface roughness<br/>of the bodies in Ra:</b><br>Internal mechanical polish<br>and electro polish<br>Ra ≤ 0,8 μm                        |            |
| <b>Size:</b>                | DN 25   |            |   |            |   |            | <b>Actuator type:</b><br>KMA for steam sterilizing<br>up to max. 160° C   |            |
| <b>Valve body material:</b> | Stainless steel,<br>forged<br>1.4435/316L ASME BPE                          |            | <b>Valve body end connection:</b><br>Butt weld tube end<br>DIN 11850 Series 2 |            | <b>Diaphragm material:</b><br>EPDM<br>FDA / USP compliant |            | <b>Actuator control function<br/>and orientation air inlet<br/>connection:</b><br>Normally closed (NC)<br>orientation 90° to flow direction |            |

System components and accessories see page 132 to 139

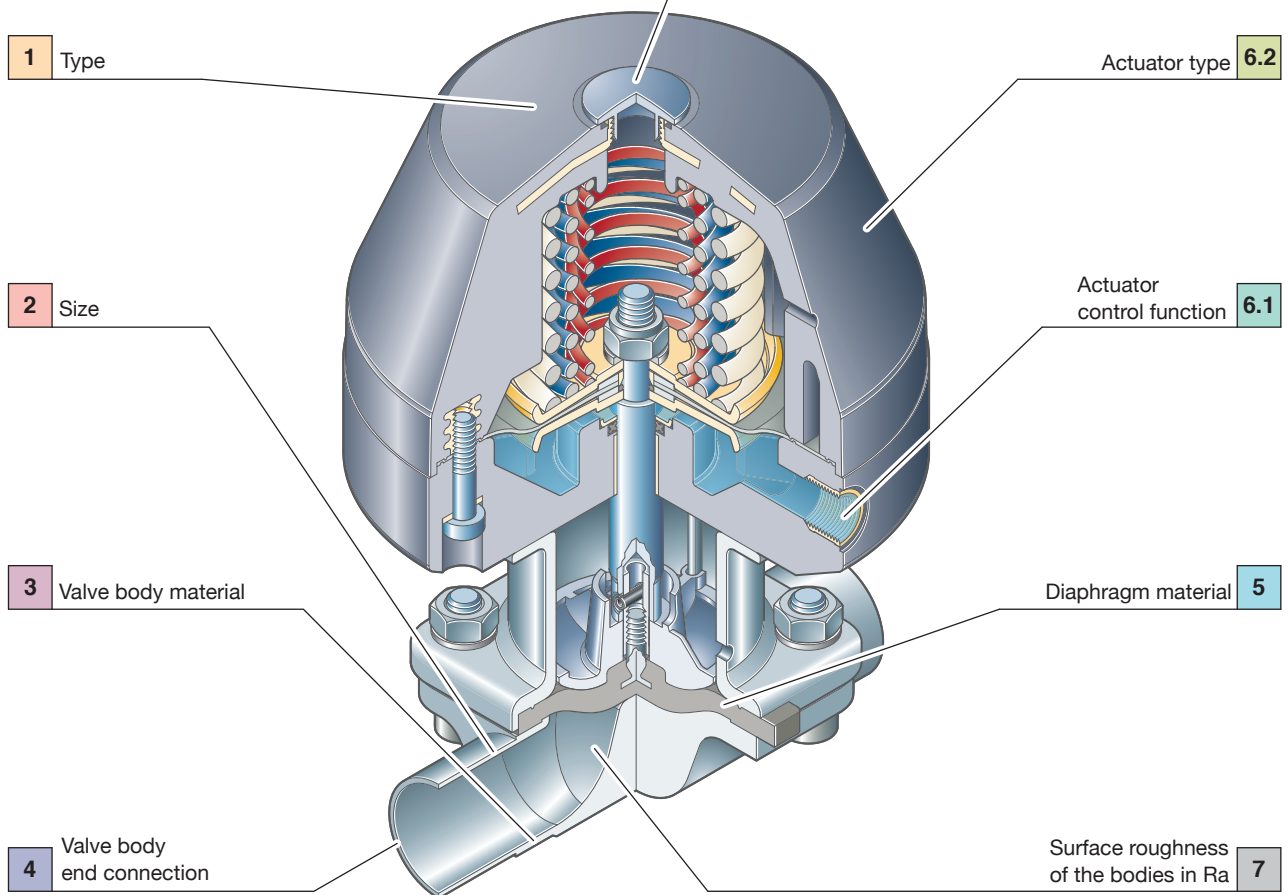





|          |   |  |
|----------|---|--|
| <b>1</b> | <b>Introduction</b><br>Overview   | Page<br>4 - 11   |
| <b>2</b> | <b>Media Contacted Components</b><br>Diaphragms<br>Valve Bodies (fold out page)<br>Butt Weld Tube Ends (fold out page)<br><b>Aseptic Connections</b>  | 14 - 19<br>20<br>21<br><b>22 - 24</b>  |
| <b>3</b> | <b>Aseptic Diaphragm Valves</b><br><b>Overview Diaphragm Aseptic Valves</b><br>Why Aseptic Diaphragm Valve?<br>Self Draining - Two-Way Valve<br>Innovative Design<br><b>Aseptic Diaphragm Valves</b><br>STERIPUR Series<br>KMA Series<br>KMD Series<br><b>Ordering Key and Ordering Example</b>   | 26, 27<br>28<br>29<br>30 - 33<br>34 - 46<br>48 - 58<br>60 - 65<br>66 - 68        |
| <b>4</b> | <b>Aseptic Diaphragm Valve Configurations</b><br><b>D-Rule</b><br><b>Welded Valve Configurations</b><br><b>Multiport Valves</b><br>Why Multiport Valves?<br>Main line open, Loop Valves (e.g. T-Valve)<br>All lines and valve ports able to close<br>The way of customized multiport valve designs<br>Specification Multiport Valves<br><b>Tank Valves</b><br><b>Process Solutions</b><br>Sterile Sampling Unit<br>Purified Steam Sampling Unit | 72<br>73 - 75<br>76<br>77 - 81<br>82 - 87<br>88<br>89<br>90 - 93<br>94<br>95     |
| <b>5</b> | <b>Angle Seat Valves</b><br>Description and Features<br>Technical Data<br>Regulating cone<br>2/2-Way Angle Seat Valves<br>Valve Body Dimensions<br>Ordering Key and Ordering Example  | 98, 99<br>100 - 101<br>102 - 105<br>106 - 114<br>115 - 117<br>118, 119           |
| <b>6</b> | <b>Ball Valves</b><br>Manual Ball Valve Description and Features<br>Pneumatically Ball Valve Description and Features<br>Technical Data<br>Ordering Key   | 123<br>124<br>125 - 128<br>129   |
| <b>7</b> | <b>System Components and Process Automation</b><br><b>Overview</b><br>Manual Adjustment - Optical Indication<br>Electrical Switch Boxes - Pilot Control<br><b>Detailed Information</b><br>3/2 Way Plastic Pilot Valve<br>Control Head Switch 024.63. - 024.89.<br>Contact-Free Limit Switch 024.50<br><b>Process Automation, Electropneumatic Positioners</b><br><b>Overview Product Range</b><br><b>Glossary</b>                               | 132<br>133<br>134<br>135, 136<br>137<br>138, 139<br>140 - 143<br>144<br>145, 146 |

## D-Rule

The D-Rule is the dead leg as a relationship between the B and D dimension as described in ASME BPE.

This definition is a helpful guideline to describe the maximum allowable dead leg of combined components which are installed into aseptic process systems or process skids.

The dead leg is described with the B dimension in mm as absolute value or as a relationship of B/D.

Depending on the nominal diameters of the combinations and / or the positioning of the valve body, the relation can shift between 2:1 and 5:1. If the D-Rule is specified and the requirements can not be met with a welded valve configuration, the solution is manufacturing of the valve body as a multiport valve which is made from solid block material.

$$\text{D-Rule} = \frac{B}{D}$$

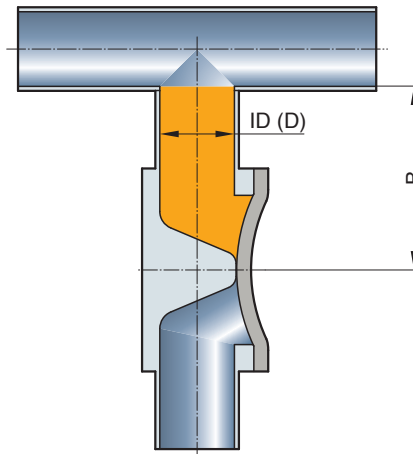

The B dimension and the relation of B/D are displayed in the dimensional data which can be provided on request.



# Welded Valve Configurations

Welded valve configurations are designed to improve the process in aseptic production facilities by reducing the dead legs in accordance to cGMP. Welded valve configurations may be as simple as a valve by tube fabrication or as complex as multiple valve bodies of different sizes welded into a valve cluster. All welded end connections are available. The applications are endless and the challenge is to efficiently meet the process needs.

Strict quality control is followed for every welded valve configuration produced by SED. All weld seams that are accessible are polished according to the interior surface specification.

The completed welded valve configuration is visually inspected and 100% are pressure tested.

### Advantages of a Welded Valve Configuration:

- Totally self draining
- Minimized dead legs
- Reduces surface contact and hold up volume of the medium
- Compact assembly
- Reduces number of welds
- Provides a ready-made assembly for field installation

During installation of welded valve configurations it is important to follow good piping practice to guarantee the valve assemblies drainability.

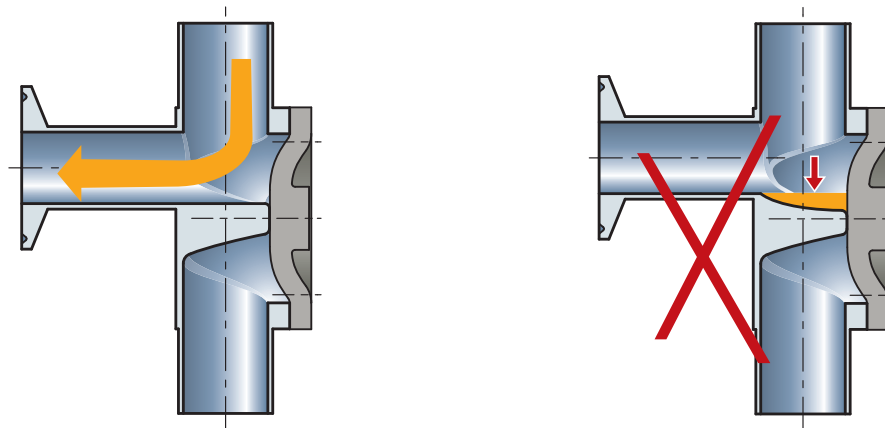

# Welded Valve Configurations

The main valve orientation distinguishes between the two different principles: SL or SA

## 1) SL – L Pattern Configurations

The SL Fabrication is utilized in a vertical piping system to eliminate dead legs in point of use applications of high purity water systems or any other distribution systems. This valve design serves as a 90-degree elbow for the piping system or as a valve by valve configuration. In a valve by valve configuration the horizontal valve is orientated at the self-draining angle.

When the vertical main valve is opened it provides a sample untainted by bacterial growth or process contamination. The size range available is up to DN 100 (4") for both the main valve and L valve or tube port.

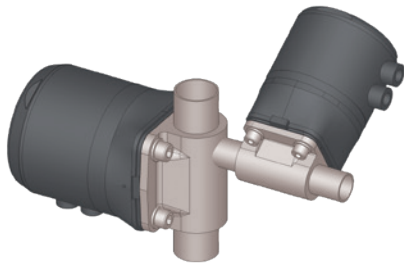

SL1.H

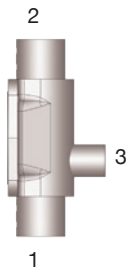

SL2.H

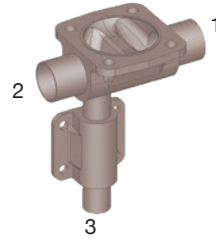
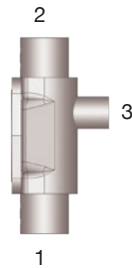

SL2.1.V

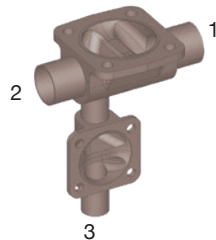

SL2.2.V

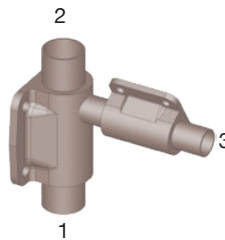

SL2.1.H

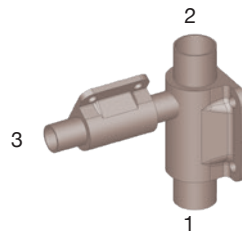

SL2.2.H

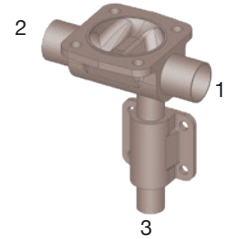

SL1.1.V

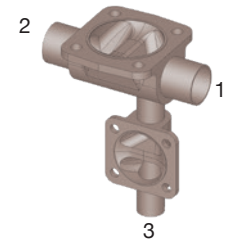

SL1.2.V

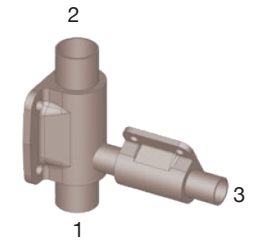

SL1.1.H

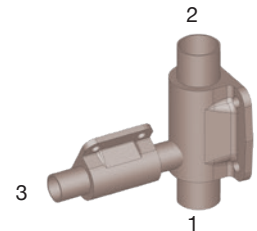

SL1.2.H

On request, all dimensional data sheets or 2D and 3D - CAD drawings are available.

All fabricated 2/2 way SA and SL orientations will have a dead leg. Manufacturing these valve orientations from a solid block body will minimize or eliminate the dead leg. See page 77 – 87.

## 2) SA – Sterile Access Configurations

The Sterile Access Fabrication is utilized in a horizontal piping system where the main valve is orientated at the self-draining angle and the access port is at the lowest drainable point of the waterway.

The sterile access maybe used for applications including sampling, steam, condensate or divert port.

The Sterile Access Fabrication is available with either a tube port or a vertical or horizontal valve port.

The size range available is up to DN 100 (4") for both the main valve and access valve or tube port.

Sterile access fabrications use two standard 2/2 way valve bodies welded together per the required orientation. In some same size (i.e. DN25 x DN25) sterile access fabrications a block body main valve may be selected for manufacturing.

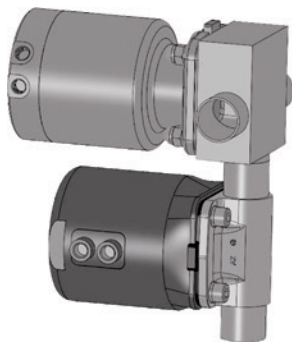

SA1.V

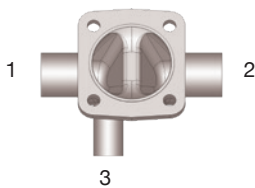

SA2.V

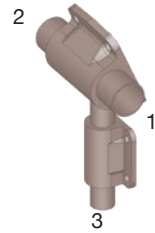
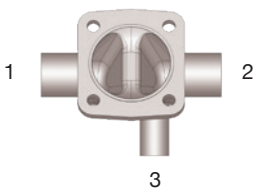

SA1.1.V

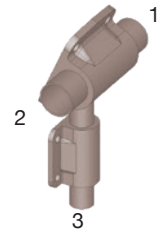

SA2.1.V

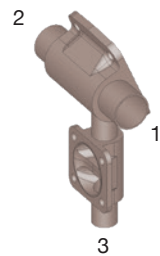

SA1.2.V

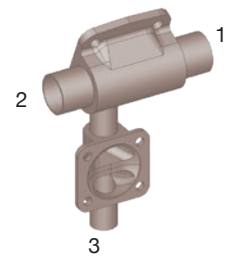

SA2.2.V

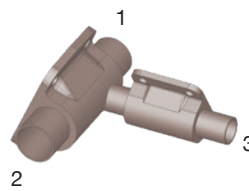

SA1.1.H

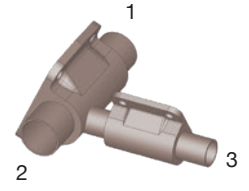

SA2.1.H

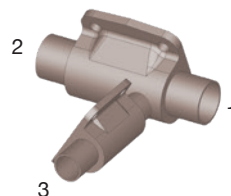

SA1.2.H

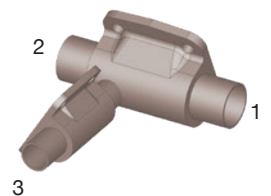

SA2.2.H

On request, all dimensional data sheets or 2D and 3D - CAD drawings are available.

All fabricated 2/2 way SA and SL orientations will have a dead leg. Manufacturing these valve orientations from a solid block body will minimize or eliminate the dead leg. See page 77 – 87.

## Why Multiport Valves?

A multiport valve consists of a valve body machined from a solid block material with a minimum of three tube ends. Multiport valves can be produced with up to 20 actuators and 40 tube ends or even more depending on the feasibility of multiport valve manufacturing. The selection and specification of multiport valves in the aseptic process industry becomes more and more important. The reason is found in the advantages the product offers in optimizing aseptic process purity and efficient product manufacturing.

Innovative conceptual designs and modern machining capabilities are integrated through the CAD-CAM system creating profitable individual solutions with a high degree of flexibility. A prerequisite for this is an operational structure which supports a close relationship between sales, engineering and manufacturing. With a high vertical range of manufacturing at its factory, SED is in an excellent position to meet these challenging market needs. The continuous innovative development of multiport block valve products is a main focus of SED.

The ideal benefit for you, our customer, is achieved through active and cooperative teamwork of both parties during the design and specification of the valves. This refers especially to the process requirements dictated by the P&ID's for proper flow direction, drainability and installation restraints.

The below illustrations compare the hold up volume and the compact design of a multiport block valve to a welded valve configuration:

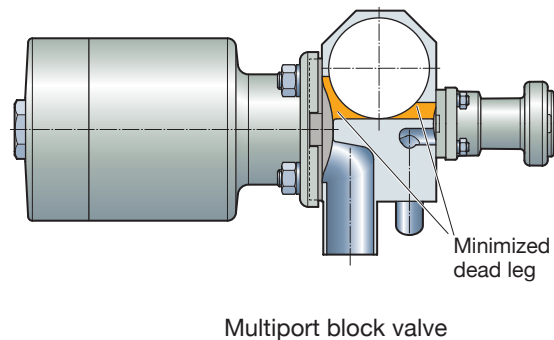
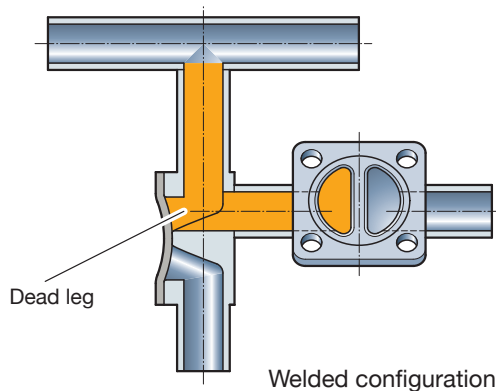

### The Advantages at a Glance:

- Customer's specific design
- Compact design and smaller envelope dimension is achievable with the Steripur Series actuators
- Combination of many different nominal diameters
- Optimized drainability
- Minimized dead leg
- Reduces surface contact, hold up volume and cross contamination of the product
- Reduction of fittings, tubing and field welds in the system
- Reduces qualification and validation documentation requirements
- All end connections and materials are available according to the customer's specification

The application of multiport block valves is mainly for the distribution, point of use, sampling, diverting, mixing, bypass, drain and process sterilization (SIP/CIP).

The complete drainability is an important consideration for the design of multiport valves. The following illustration shows the correct and incorrect installation of a standard T-valve:

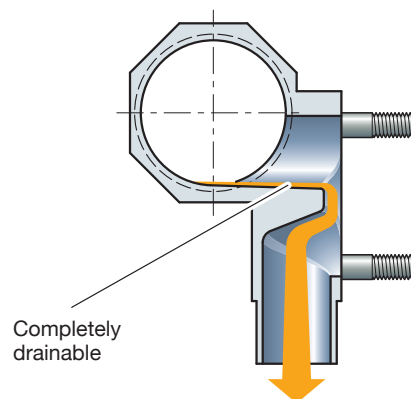
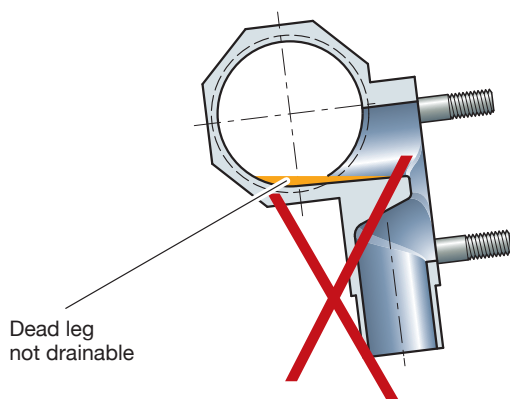

# Multiport Valves

The following Multiport Valve pages display a selection of multiport block valves. These are examples that should assist in specifying the multiport block body. Up to size DN100 (4.0") and larger nominal diameters and nominal diameter combinations are available. Within this range, all tube standards, tube end orientations, and other application specific customized blocks can be specified. Some of the multiport block valves have become standard products for SED and years of development and manufacturing has allowed for efficiency in production.

**For the differentiation in the following tables, two main criteria are considered:**

- 1) Multiport blocks with main line open for circulation (page 77 to 81)
- 2) Multiport blocks with all lines and valve ports able to close (page 82 to 87)

## 1) Main line open

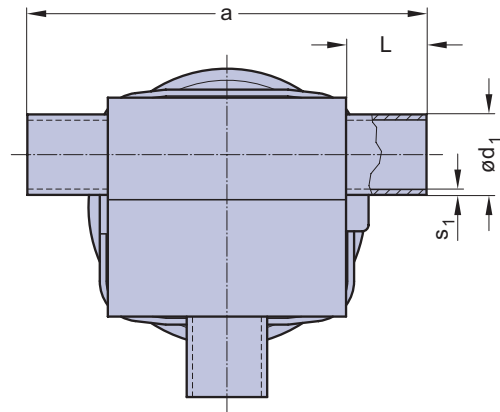
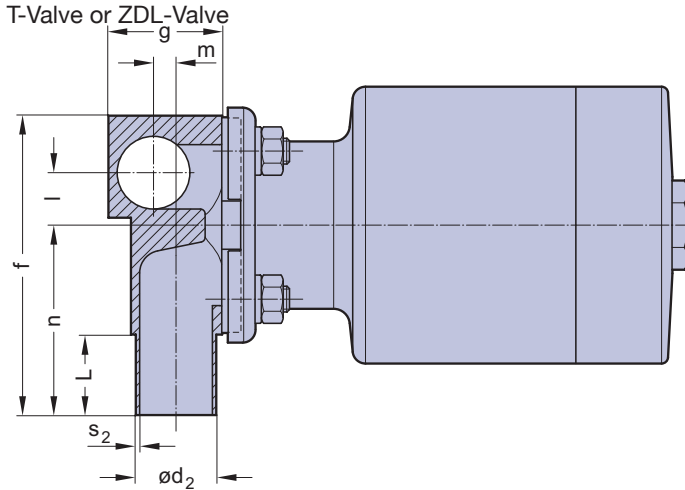

On request, all dimensional data sheets or 2D and 3D - CAD drawings are available.

### Description

For valve specification see page 89 as guideline

### P&ID

- Flow direction
- Drain direction
- ⊗ Valve

### Illustration

Actuators and other options are included in some of the illustrations

### 1.1)

#### T-Valve or ZDL-Valve

1 x Point of use or sampling valve port  
Optional available with U-bend for easy fit into the loop

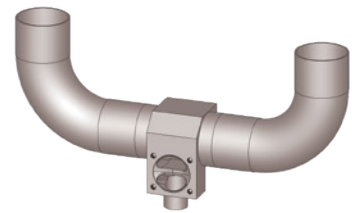
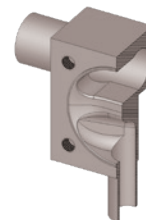
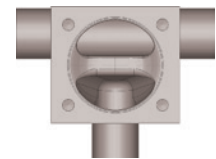
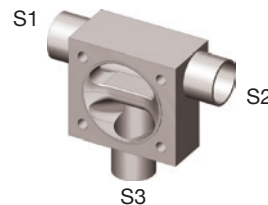
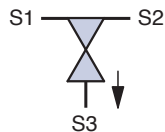

Recommended installation:  
S3 down

## 1) Main line open

### Description

For valve specification see page 89 as guideline

### P&ID

- ⇒ Flow direction
- Drain direction
- ⊘ Valve

### Illustration

Actuators and other options are included in some of the illustrations

#### 1.15)

**TL- Valve, actuation left side**  
(illustration)

**TR-Valve, actuation right side**

1 x Point of use or sampling valve port

Main line vertical

Recommended installation:  
S3 - 45° down

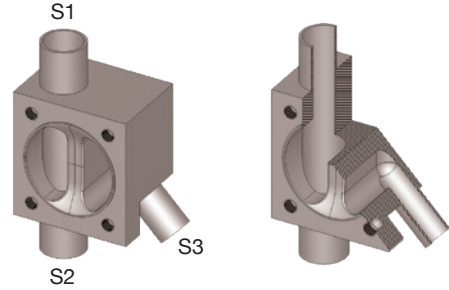
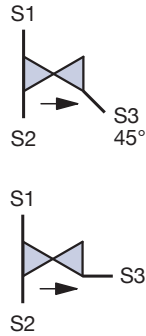

#### 1.16)

**TH- Valve**

1 x Point of use or sampling valve port

Main line vertical and with horizontal outlet port

Recommended installation:  
S2 down

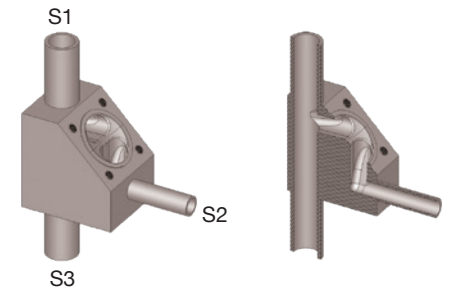
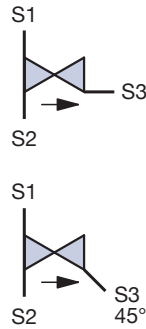

#### 1.2)

**LL 3/1 - S2 left side**

(illustration)

**LR 3/1 - S2 right side**

1 x Point of use valve port with integrated directional flow 90° to the main line

Recommended installation:  
S3 down

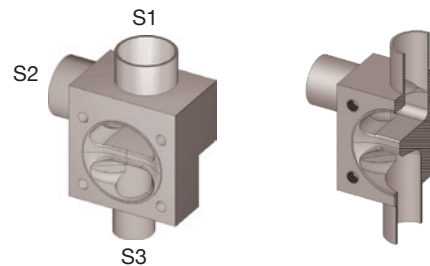
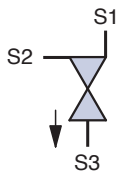

#### 1.13)

**TY-Valve**

2 x Point of use or sampling valve ports

Optional available with U-bend for easy fit into the loop

Recommended installation:  
S3 and S4 - 45° down

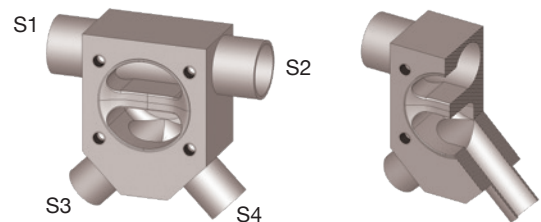
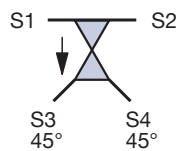

# Multiport Valves

## 1) Main line open

### Description

For valve specification see page 89 as guideline

### P&ID

- ➔ Flow direction
- ➔ Drain direction
- ⌘ Valve

### Illustration

Actuators and other options are included in some of the illustrations

#### 1.4)

**MZL 4/2 – S4 left side**  
**MZR 4/2 – S4 right side**

(illustration)

1 x Point of use valve port  
 1 x Integral loop sample valve port  
 Sample valve be provides on either side of the valve body.

**Back to back valve actuation**

Recommended installation:  
 S3 down

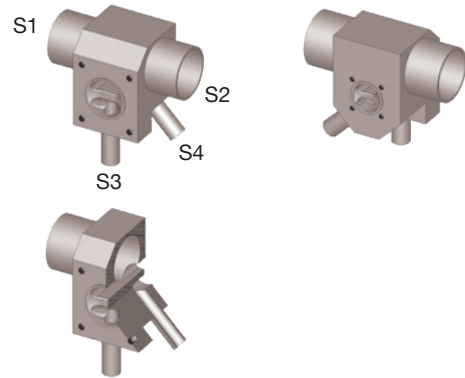
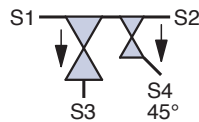
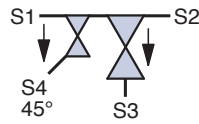

#### 1.45)

**MTL 4/2 – S4 left side**  
**MTR 4/2 – S4 right side**

(illustration)

2 x Point of Use Valve Port or  
 Double Zero Dead Leg Tee Valve  
 with different diaphragm size.

One port maybe used for sam-  
 pling and the second port for  
 downstream processing.

**One side valve actuation**

Recommended installation:  
 S3 and S4 down

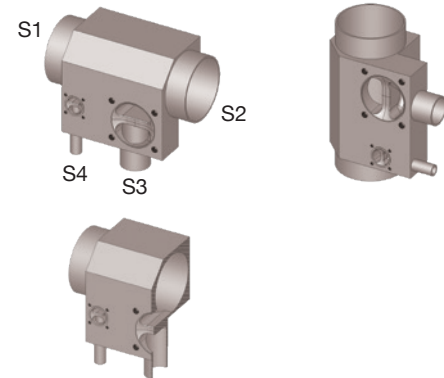
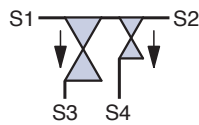
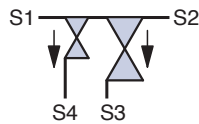

#### 1.6)

**MXL 4/2 – S4 left side**  
**MXR 4/2 – S4 right side**

(illustration)

1 x Point of use valve port  
 1 x Integral sample purge valve,  
 valve port below the weir.

Sample valve be provides on  
 either side of the valve body.

**Back to back valve actuation**

Recommended installation:  
 S3 down

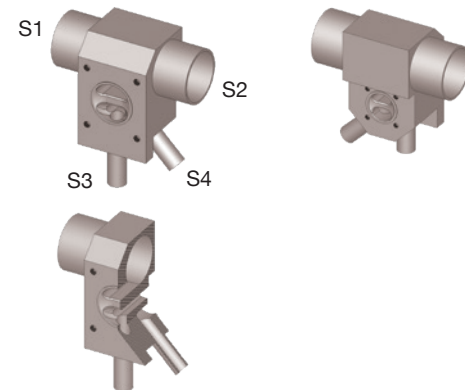
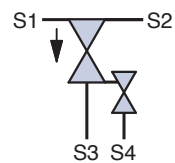
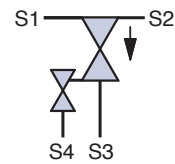

#### 1.61)

**MKL 4/2 – S4 left side**  
**MKR 4/2 – S4 right side**

(illustration)

1 x Point of use valve port  
 1 x Integral sample purge valve,  
 valve port below the weir.

Sample valve be provides on  
 either side of the valve body.

**No valve actuation on the  
 back side**

Recommended installation:  
 S3 down

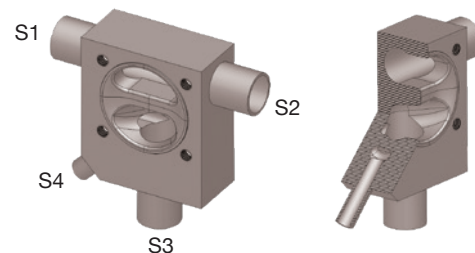
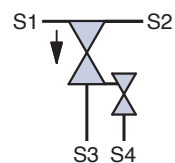
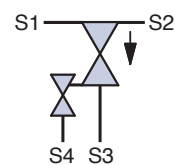

## 1) Main line open

### Description

For valve specification see page 89 as guideline

### P&ID

- ⇒ Flow direction
- Drain direction
- ⊘ Valve

### Illustration

Actuators and other options are included in some of the illustrations

#### 1.7)

#### MWL 5/3 – S4 left side

(illustration)

#### MWR 5/3 – S4 right side

1 x Point of use valve port

1 x Integral loop sample valve port

1 x Integral sample purge valve port below the weir.

Sample and purge valve be provides on either side of the valve body.

#### Back to back valve actuation

Recommended installation:

S3 down

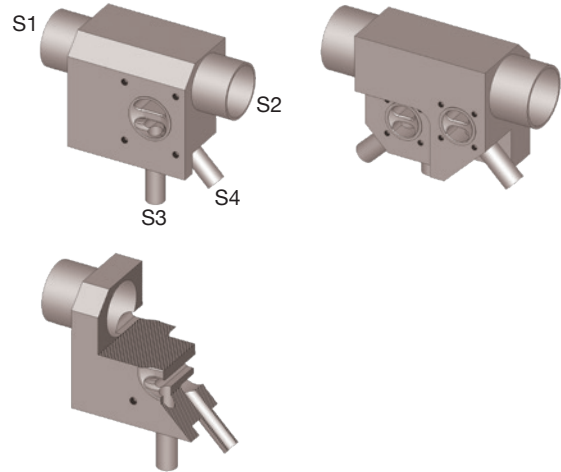
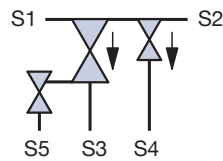
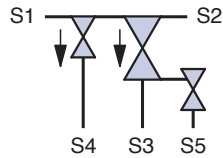

#### 1.72)

#### MVL 5/3 – S4 left side

(illustration)

#### MVR 5/3 – S4 right side

1 x Point of use valve port

1 x Integral loop sample valve port

1 x Integral sample purge valve port below the weir.

Sample and purge valve be provides on either side of the valve body.

#### No valve actuation on the back side

Recommended installation:

S3 down

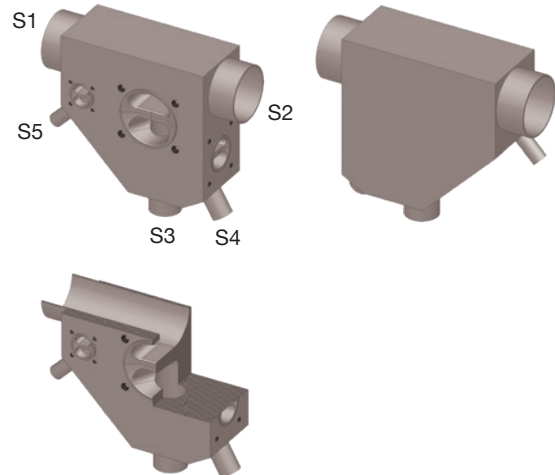
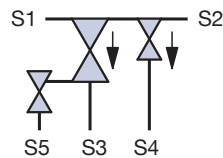
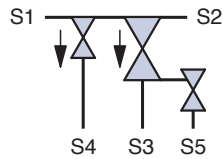

#### 1.9)

#### MTE 6/4

4 x Point of use valve ports

The Number of valve ports is variable.

#### No valve actuation on the back side

Recommended installation:

S1 and S2 horizontal

S3 to S6 vertical down or vertical up orientation.

S1 and S2 can be vertical if tube outlets S3 to S6 are positioned to the lowest point of valve pocket like the picture shows

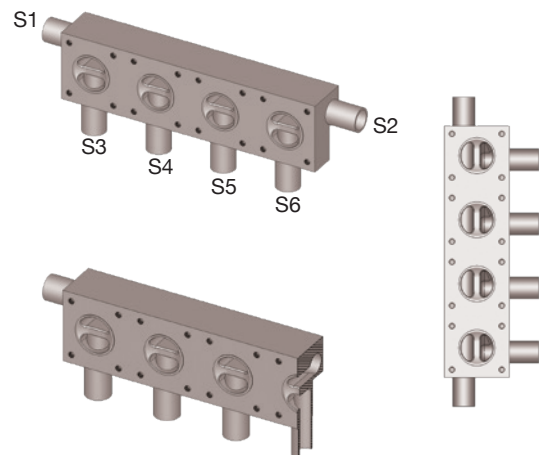
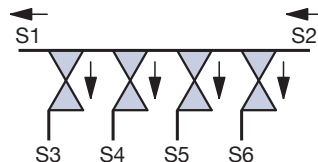



# Multiport Valves

## 1) Main line open

### Description

For valve specification see page 89 as guideline

### P&ID

- Flow direction
- Drain direction
- ⊗ Valve

### Illustration

Actuators and other options are included in some of the illustrations

#### 1.11)

##### MTD 7/5

5 x Point of use valve ports  
The number of valve ports is variable.

##### Back to back valve actuation

Recommended installation:  
S1 and S2 horizontal  
S3 to S7 can be vertical if tube outlets S3 to S7 are positioned to the lowest point of valve pocket like the picture shows.

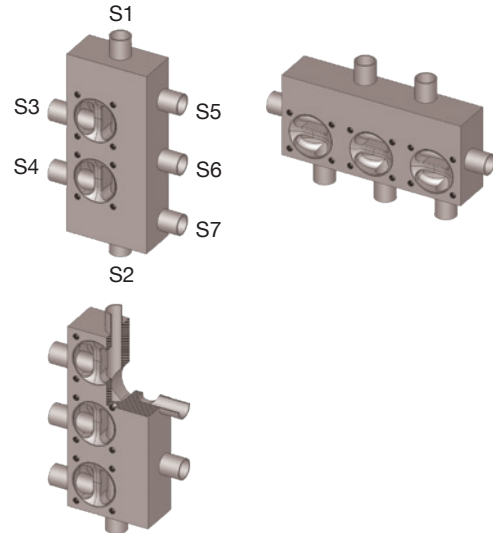
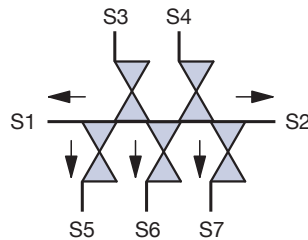

#### 1.14)

##### MCE 4/2 to 16/14

2 to 14 Point of use valve ports  
The number of valve ports is variable

##### No valve actuation on the back side

Recommended installation:  
S1 and S2 horizontal  
S3 to S4 or max S16 down or vertical up orientation.  
S1 and S2 can be vertical if tube outlets S3 to S4 or max S16 are positioned to the lowest point of valve pocket like the picture shows.

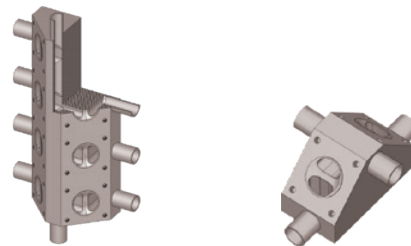
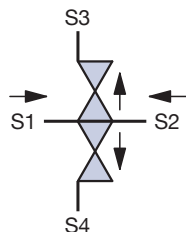
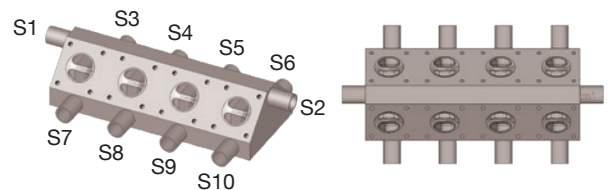
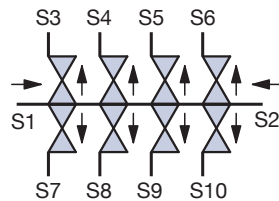

#### 1.16)

##### MFF 4/2 to 32/30

##### Up to 30 point of use valve ports as flexible manifold system

Dependent on the requirements the number of valves installed can be between 2 and 30.  
It is a mirror design to be suitable also for applying clamp connection.  
It allows standardizing skirts and other system solutions.  
Aseptic O-ring connection according ASME/BPE and DIN 11864 see also catalogue page 23

##### Back to back valve actuation

Recommended installation:  
S4 down

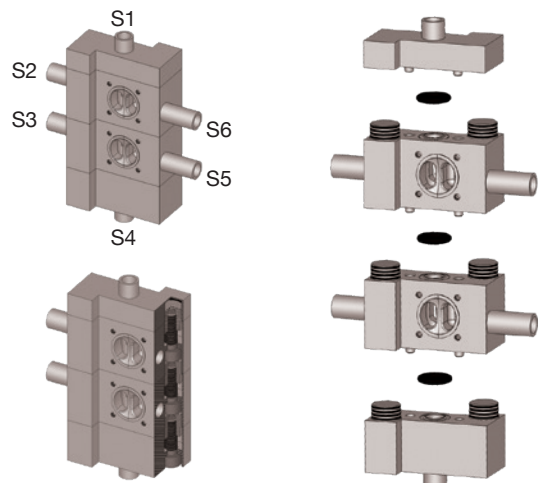
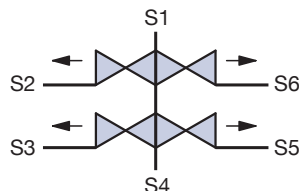

## 2) All lines and valve ports able to close

### Description

For valve specification see page 89 as guideline

### P&ID

- Flow direction
- Drain direction
- ⊘ Valve

### Illustration

Actuators and other options are included in some of the illustrations

### 2.1)

#### MFE 3/2

- 1 x Valve horizontal
- 1 x Valve vertical

#### Back to back valve actuation

Recommended installation:  
Dependent on design and application

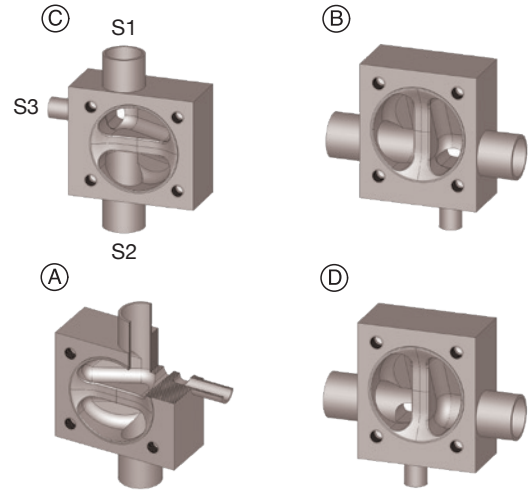
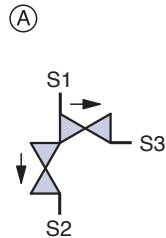

### 2.15)

#### MBE 3/2

- 1 x Valve horizontal
- 1 x Valve vertical

Function similar to pos. 2.1 but

#### No valve actuation on the back side

Recommended installation:  
Dependent on design and application

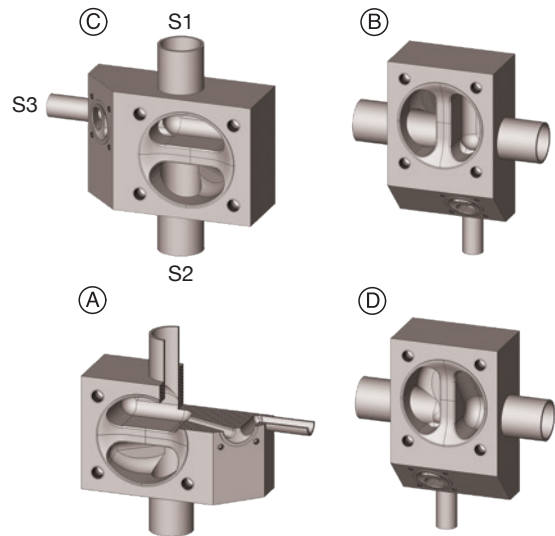
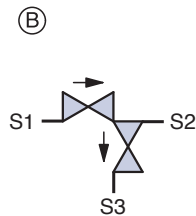

### 2.17)

#### MCE 3/2

- 1 x Valve horizontal
- 1 x Valve vertical

Illustration shows one version only.

Function similar to pos. 2.1

Recommended installation:  
Dependent on design and application

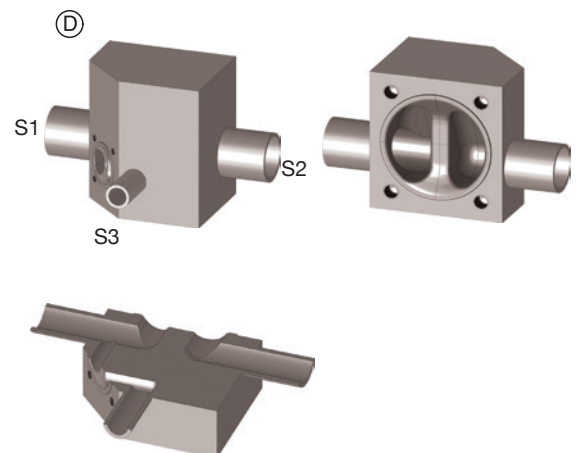
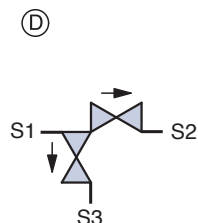

# Multiport Valves

## 2) All lines and valve ports able to close

### Description

For valve specification see page 89 as guideline

### P&ID

- Flow direction
- Drain direction
- ⊗ Valve

### Illustration

Actuators and other options are included in some of the illustrations

### 2.25)

#### MFE 3/2

2 x Valve horizontal

#### Back to back valve actuation

Recommended installation:  
S1 vertical down or vertical up  
Dependent on design and application

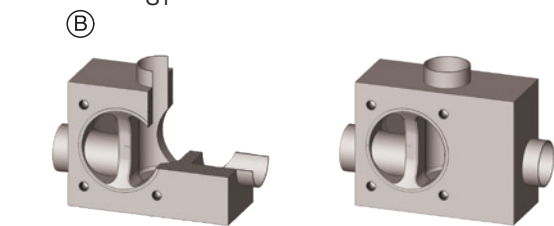
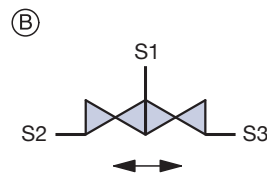
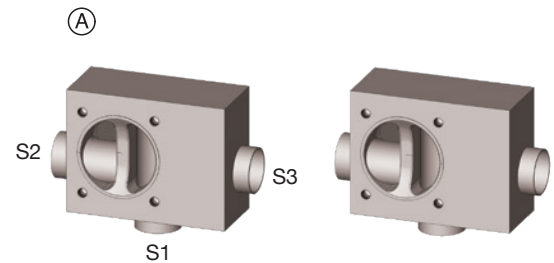
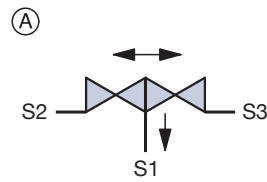

### 2.31)

#### MCE 3/2

2 x Valve horizontal

Function similar to pos. 2.25 but  
**no valve actuation on the back side**

Recommended installation:  
S1 horizontal or vertical  
The 2-way divert valve block body allows for many different inlet and outlet orientations. Some of them are illustrated

(A) + (B)

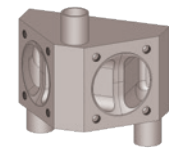
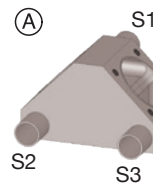
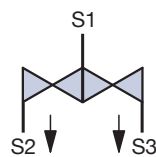

(C)

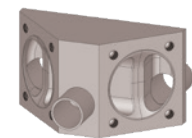
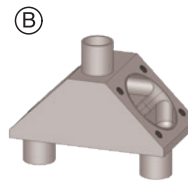
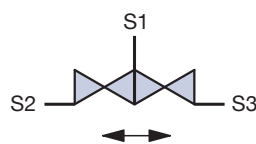

(C)

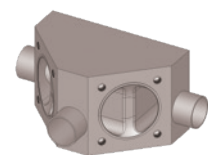
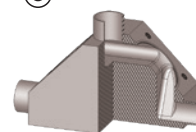

### 2.35)

#### MFE 3/3

2 x Valve horizontal

1 x Valve vertical

#### Back to back valve actuation

Recommended installation:  
S3 vertical down or vertical up

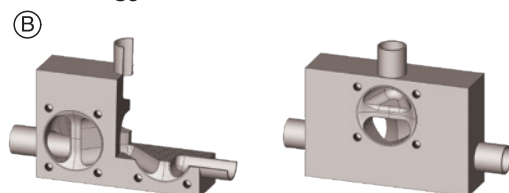
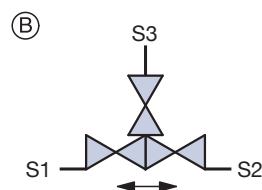
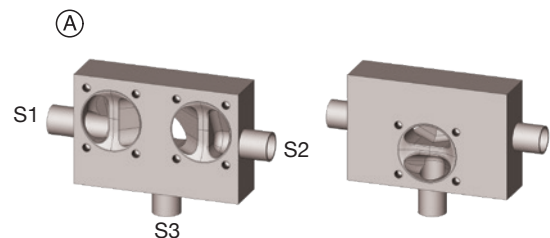
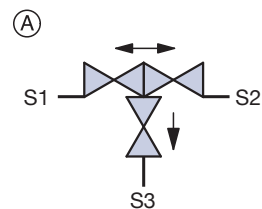

## 2) All lines and valve ports able to close

### Description

For valve specification see page 89 as guideline

### P&ID

- Flow direction
- Drain direction
- ⊘ Valve

### Illustration

Actuators and other options are included in some of the illustrations

#### 2.38)

#### MCE 3/3

2 x Valve horizontal

1 x Valve vertical

Function similar to pos. 2.35 but

**no valve actuation on the back side**

Recommended installation:

S3 vertical down or vertical up

The valve block body allows for many different inlet and outlet orientations.

Some of them are illustrated

Dependent on design and application

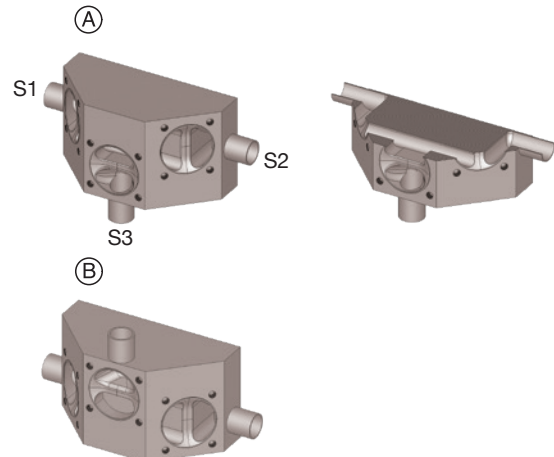
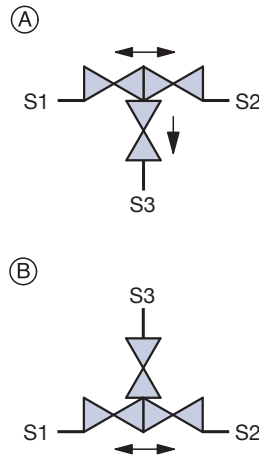

#### 2.41)

#### MFE 4/3

1 x Valve horizontal

2 x Valve vertical

**Back to back valve actuation**

Recommended installation:

Main line isolation through S3 and S4, S1 vertical up sterili-

zation valve port, S2 vertical

down sterilization valve port.

Or S3 and S4 vertical dependent

on design and application.

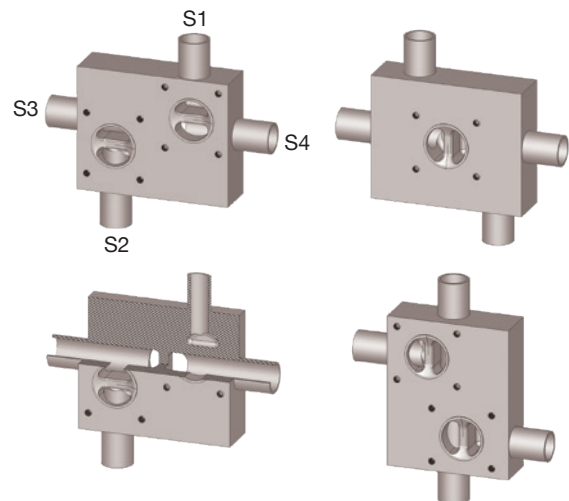
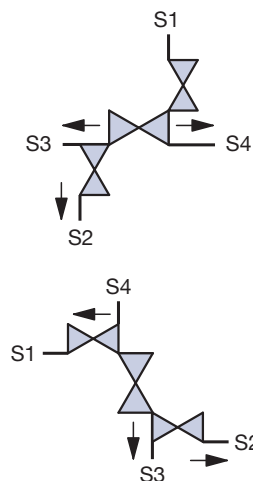

#### 2.43)

#### MFE 4/3

1 x Valve horizontal

2 x Valve vertical

**Back to back valve actuation**

Recommended installation:

S2, S3 vertical down or

dependent on design

and application

S4 vertical down.

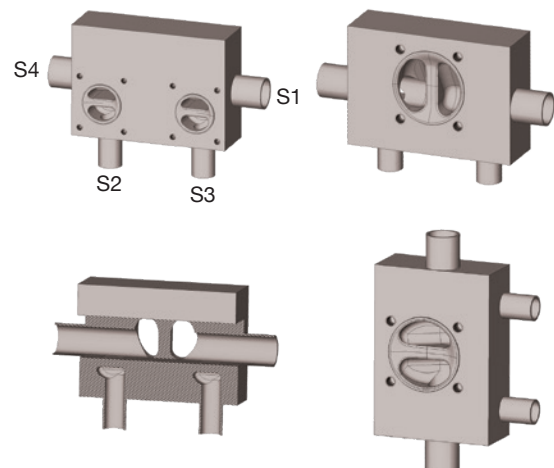
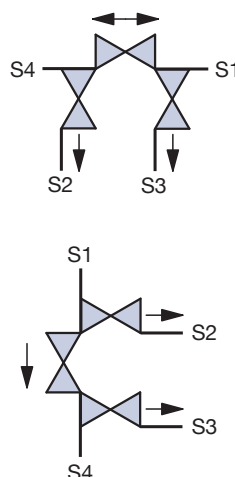

# Multiport Valves

## 2) All lines and valve ports able to close

### Description

For valve specification see page 89 as guideline

### P&ID

- ⇒ Flow direction
- Drain direction
- ⊘ Valve

### Illustration

Actuators and other options are included in some of the illustrations

### 2.49)

#### MFE 4/4

2 x Valve horizontal  
2 x Valve vertical

#### Back to back valve actuation

Recommended installation:  
S2 vertical down

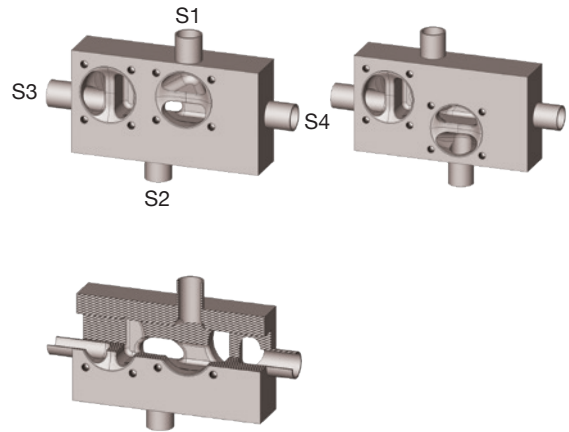
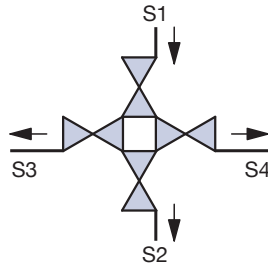

### 2.51)

#### MBE 4/4

2 x Valve horizontal  
2 x Valve vertical

Function similar to pos. 2.35 but  
**no valve actuation one the back side**

Recommended installation:  
S2 vertical down or  
S1 and S2 horizontal  
The valve block body allows  
for many different inlet and  
outlet orientations.  
Dependent on design and  
application

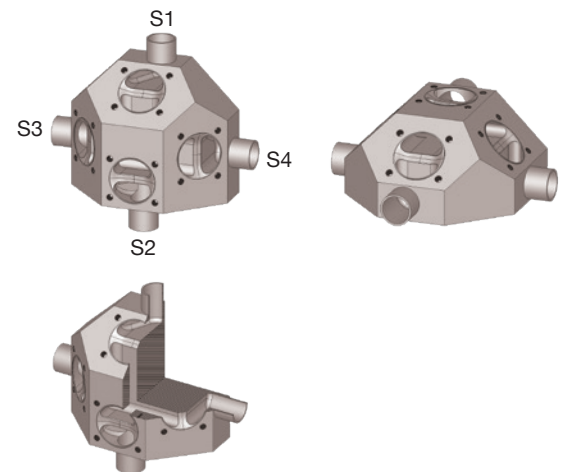
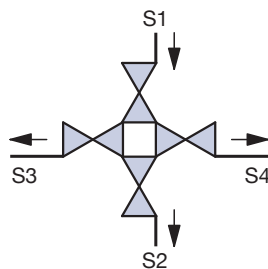

### 2.71)

#### MFE 5/4

2 x Valve horizontal  
2 x Valve vertical

#### Back to back valve actuation

Recommended installation:  
S3, S4, S5 vertical down  
Dependent on design and  
application  
S3, S4, S5 vertical up

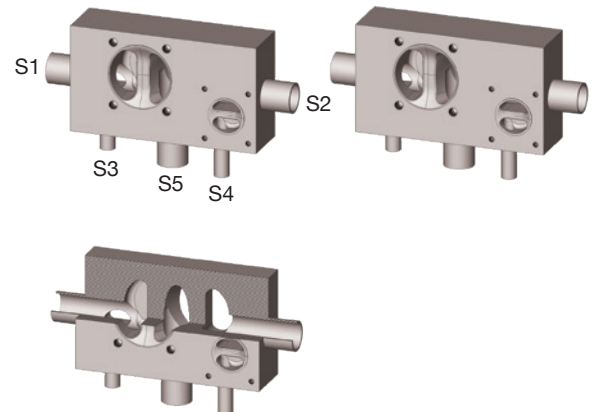
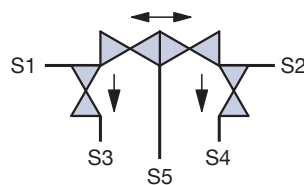

## 2) All lines and valve ports able to close

### Description

For valve specification see page 89 as guideline

### P&ID

- ⇒ Flow direction
- ➔ Drain direction
- ⊘ Valve

### Illustration

Actuators and other options are included in some of the illustrations

### 2.72)

#### MFE 4/4

2 x Valve horizontal  
2 x Valve vertical

#### Back to back valve actuation

Recommended installation:  
S3 and S4 vertical down  
Dependent on design  
and application  
S3 and S4 vertical up

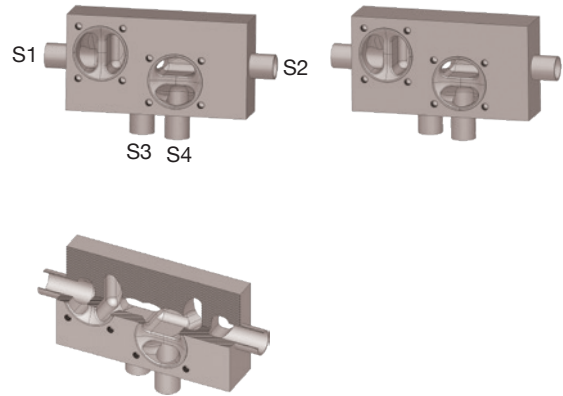
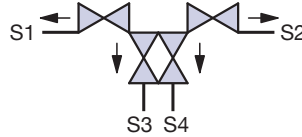

### 2.73)

#### MFE 4/4

2 x Valve horizontal  
2 x Valve vertical

#### Back to back valve actuation

Recommended installation:  
S3 and S4 vertical down  
Dependent on design  
and application  
S3 and S4 vertical up

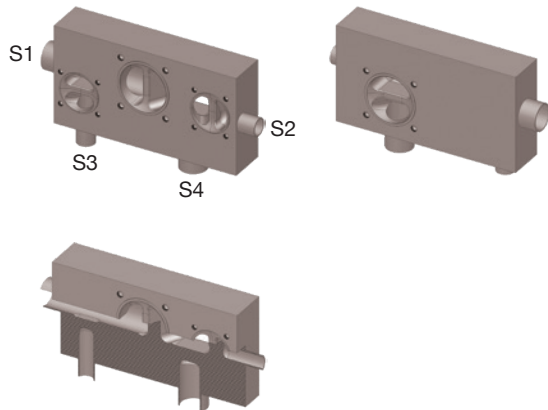
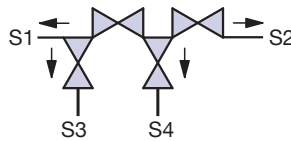

### 2.8)

#### MDE 4/4

no valve actuation on the back side

Chromatography valve without bypass

#### MDE 4/5

no valve actuation on the back side

Chromatography valve with bypass

Recommended installation:  
S2 and S4 horizontal  
S1 and S3 horizontal.  
Or S1 to S4 horizontal

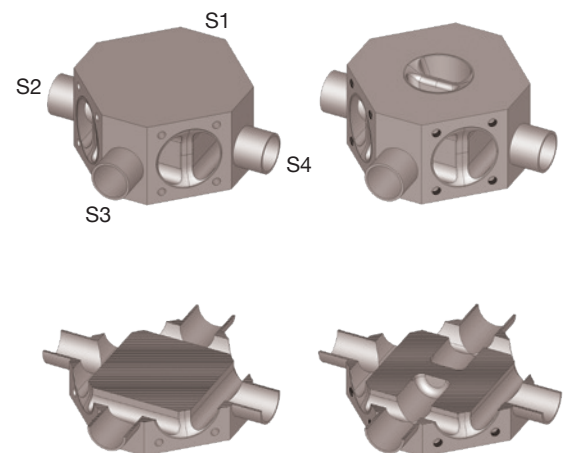
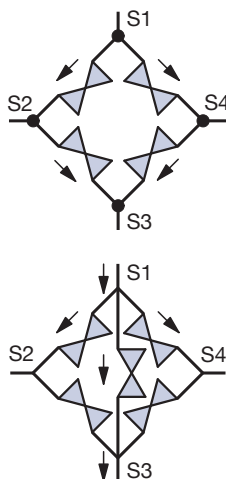

# Multiport Valves

## 2) All lines and valve ports able to close

### Description

For valve specification see page 89 as guideline

### P&ID

- ⇒ Flow direction
- Drain direction
- ⊘ Valve

### Illustration

Actuators and other options are included in some of the illustrations

### 2.81)

#### MFE 4/5

3 x Valve vertical  
2 x Valve horizontal

Recommended installation:  
S1 vertical up or down  
Dependent on design and application

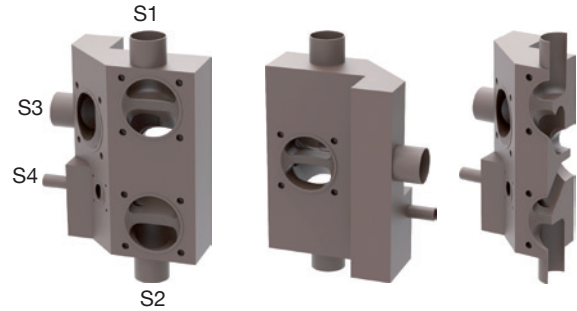
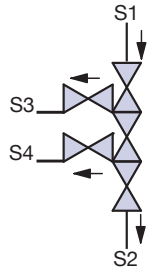

### 2.9)

#### MCS 4/3 Star Design

3x Valves vertical

#### MCS 5/4 Star Design

4x Valves vertical

#### MCS 6/5 Star Design

5x Valves vertical

**no valve actuation on the back side**

Recommended installation:  
S1 vertical; Depending on the diameter the star design is available with up to 7 valves. The star design has also been manufactured with two opposing multiport block valves with one common port connection.

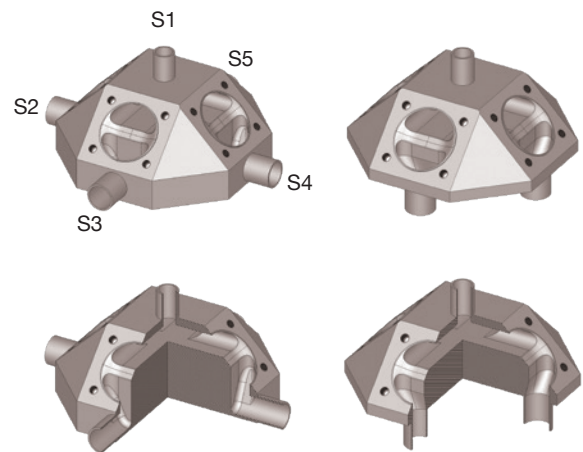
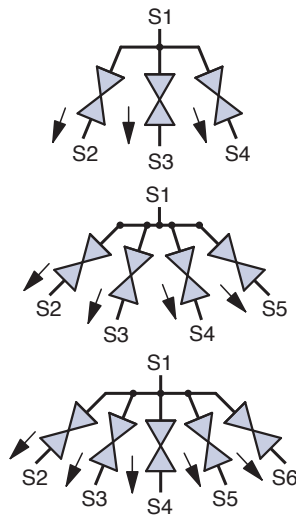

### 2.91)

#### MTA 5/5

5 Valves horizontal with one for drainage

**no valve actuation on the back side**

Recommended installation:  
S5 as drainage valve.  
Different inlet and outlet orientations e.g. S5 as inlet valve.

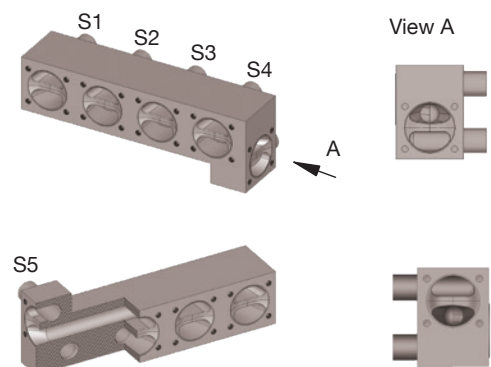
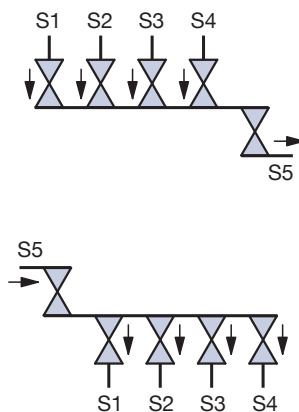

# Multiport Valves

## The way of customized multiport valve designs

From the piping and instrumentation diagram (P&ID) to the finished plant installation of pharmaceutical and bio pharm projects.

P&ID Multiport Valve Cluster

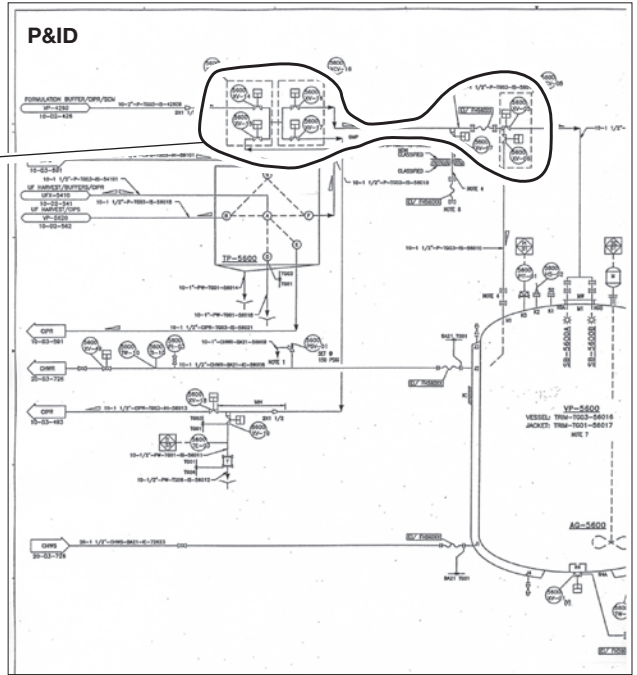
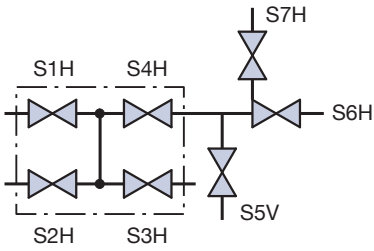

Drawing Multiport Valve Cluster

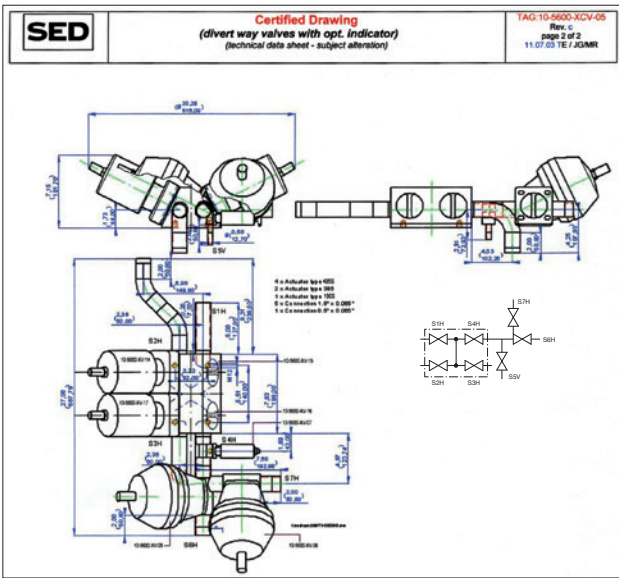

Images of the installation

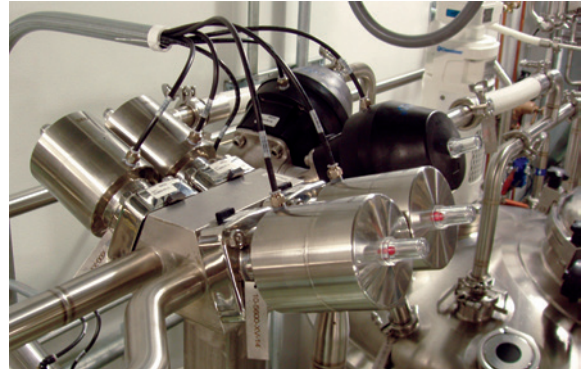

Multiport Valve Cluster

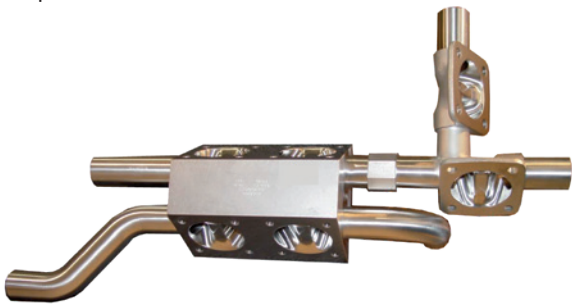



# Multiport Valves



For multiport valve configuration, please use our online configurator.



In case it is a version not yet to find in the configurator, please use this from.

## Specification form

**Your P&ID Sketch:**

**Example: P&ID**

Tube End: S1, S2, ...

Preferred Installation: Horizontal (H) / Vertical (V)

Flow Direction:  $\Rightarrow$

Drain Direction:  $\rightarrow$

Valve Seat:

Working pressure: \_\_\_\_\_ bar

Working temperature: \_\_\_\_\_ °C

**Multiport valve body material:**

1.4435/316L

1.4435/316L (Fe < 0,5%)

Other \_\_\_\_\_

**Surface finish multiport body:**

02 Ra ≤ 0,8 μm

03 Ra ≤ 0,8 μm e-polished

07 Ra ≤ 0,6 μm

08 Ra ≤ 0,6 μm e-polished

09 Ra ≤ 0,4 μm

10 Ra ≤ 0,4 μm e-polished

**Diaphragm material:**

EPDM Code \_\_\_\_\_

PTFE Code \_\_\_\_\_

Other \_\_\_\_\_

Page in catalogue:

Page 21

Page 26 - 27

Page 132 - 139

| Tube end No | Preferred Installation | Tube end connection |       |       |      | Actuator      |                  | Other                  |
|-------------|------------------------|---------------------|-------|-------|------|---------------|------------------|------------------------|
|             |                        | DN                  | s[mm] | D[mm] | Code | Actuator Type | Control Function | Accessories / Comments |
| S1          |                        |                     |       |       |      |               |                  |                        |
| S2          |                        |                     |       |       |      |               |                  |                        |
| S3          |                        |                     |       |       |      |               |                  |                        |
| S4          |                        |                     |       |       |      |               |                  |                        |
| S5          |                        |                     |       |       |      |               |                  |                        |
| S6          |                        |                     |       |       |      |               |                  |                        |
| S7          |                        |                     |       |       |      |               |                  |                        |
| S8          |                        |                     |       |       |      |               |                  |                        |
| S9          |                        |                     |       |       |      |               |                  |                        |
| S10         |                        |                     |       |       |      |               |                  |                        |
| S11         |                        |                     |       |       |      |               |                  |                        |
| S12         |                        |                     |       |       |      |               |                  |                        |

# Tank Valves

The SED Tank Bottom Valve is designed for applications in the aseptic process industry offering a pocket-free interior surface, minimized sump, eliminating entrapment areas and minimizing flow resistance thus reducing the potential for process contamination. The SED tank bottom valve incorporates the same features and performance of a standard diaphragm valve utilizing the same valve components for a flush mounted tank bottom valve or side mounted tank and sample valve.

The tank valve body is machined as standard from solid bar stock material 1.4435/316L ASME BPE and other alloy materials are available according to the specification. The standard design offers one valve port outlet. There are a number of different options available for sampling, sterilization and multi-outlet configurations that are standard in the SED product range of customized solutions.

It is preferred to weld in the tank valve directly in the vessel. Mounting the valve directly to the tank minimizes the hold up volume, the most important criteria for this application. If removal of the tank valve from the tank is required, versions are offered with flange or clamp connections. Please consult an SED technical representative for these options.

Tank bottom valves are typically used for tank discharge, draining, sampling, cleaning and/or sterilizing, rinsing and isolation of down stream processing.

The outlet port of the tank valve is available with all butt weld tube end standards (see fold-out page 21), aseptic clamp, screw connection (see page 22 and 24) or other special ends. The size range available is the same as the two-way valve.

### Features:

- Tank body machined from a solid bar stock material
- Material 1.4435/316L ASME BPE
- Other alloy options available as specified
- Minimized dead leg and internal sump
- Suitable for mounting with SED Steripur Series and KMA Series Actuation
- Optional manual operation via an extended crankshaft stem

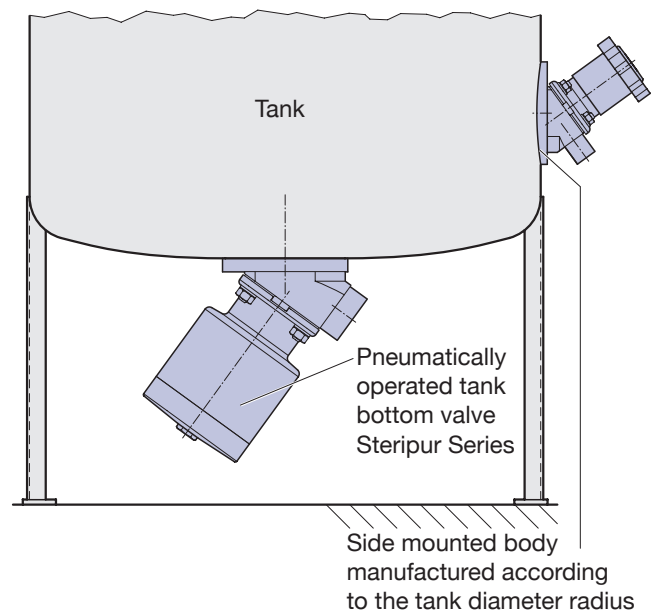
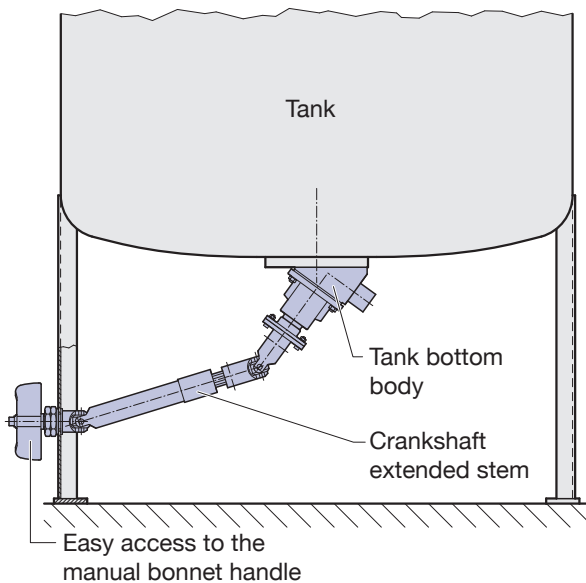

Steripur Series Manual



Steripur Series Pneumatically Operated



KMA Series Manual



KMA Series Pneumatically Operated



# Tank Valves

**Example:**  
Drawing Steripur Series pneumatically operated

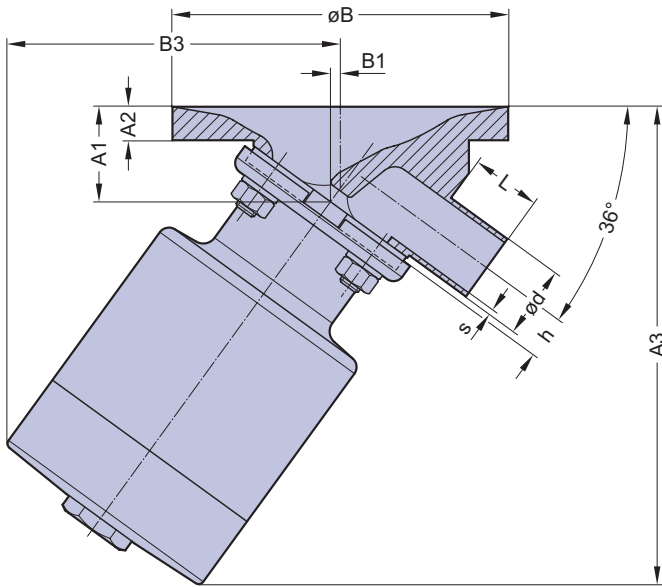

Common design

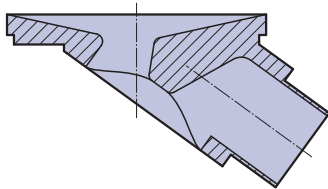

**Example:**  
Drawing KMA Series manually operated

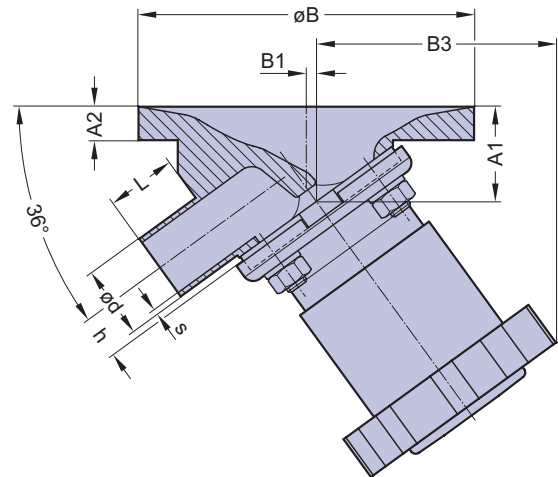

### Advantages of the SED design:

- minimized hold up volume
- better mixability of media

On request, all dimensional data sheets or 2D and 3D - CAD drawings are available.

These include options for sampling, sterilization, and multi-outlet configurations.

The following two pages show a table of some examples of standard and customized designs of tank diaphragm valves.

### Description

Select a tank valve or see page 89 to sketch and specify your solution

### P&ID

- Flow direction
- Drain direction
- ⊗ Valve

### Image

Actuators and other options are included in some of the illustrations

1)

**BT**

1x Valve port

Standard tank bottom body

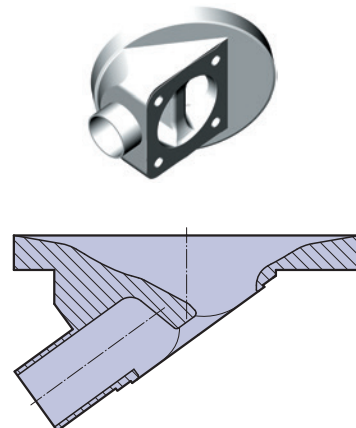
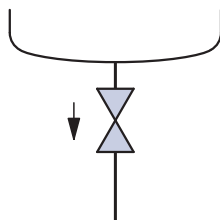

# Tank Valves

## Description

Select a tank valve or see page 89 to sketch and specify your solution

## P&ID

→ Flow direction  
 → Drain direction  
 Valve

## Image

Actuators and other options are included in some of the illustrations

2)

### 1x Valve machined from bar stock

**BZL 3/1** with one welded valve tank side left

**BZR 3/1** with one welded valve tank side right

**BXL 3/1** with one welded valve outlet left

**BXR 3/1** with one welded valve outlet right

**BW 4/1** with one welded valve tank side left and one welded valve outlet right

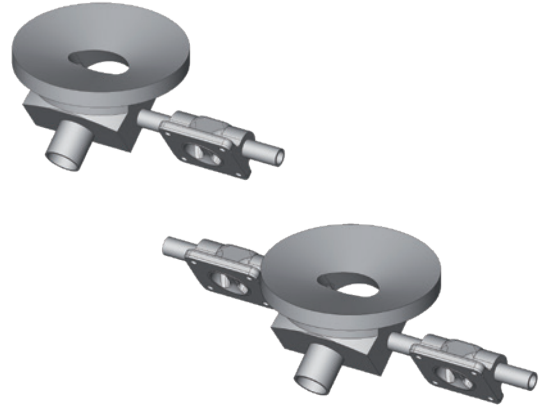
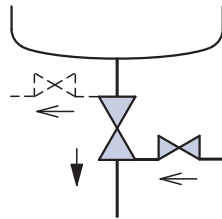

For all options the welded valve is rotated into the self draining position and extended to eliminate interference with the tank bottom

3)

### **BZR 3/2** (Illustration)

1x Main Valve

1x Sample valve tank side right

### **BZL 3/2**

1x Main Valve

1x Sample valve tank side left

Like position 2 but includes an integral sample valve tank side. Right side and left side options are available and are fully drainable.

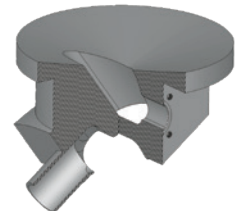
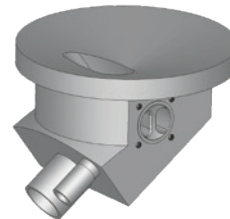
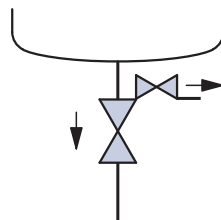

4)

### **BXL 3/2** (Illustration)

1x Main Valve

1x Sample valve outlet left

### **BXR 3/2**

1x Main Valve

1x Sample valve outlet right

Like position 2 but includes an integral outlet valve. Right side and left side options are available and are fully drainable.

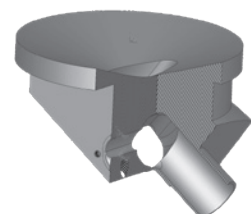
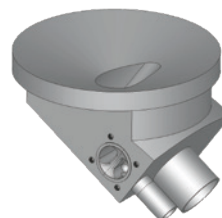
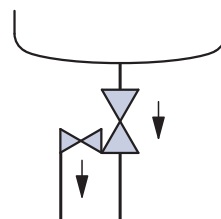

## Description

Select a tank valve or see page 89 to sketch and specify your solution

## P&ID

- Flow direction
- ▶ Drain direction
- ⊘ Valve

## Image

Actuators and other options are included in some of the illustrations

5)

### BW 4/3

1x Main Valve  
 1x Sample valve tank side right  
 1x CIP/ SIP cleaning outlet valve left  
 Like position 2 but includes integral valves that are fully drainable.

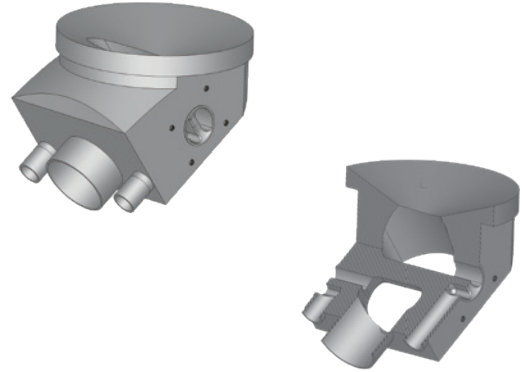
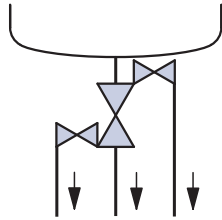

6)

### BT 3/1

1x Main valve  
 2x Outlet port for loop installation or as two access ports

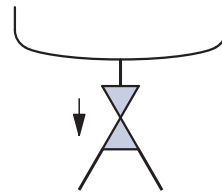

6.5)

### BFL

Like position 4, but with flange for dismantling possibility

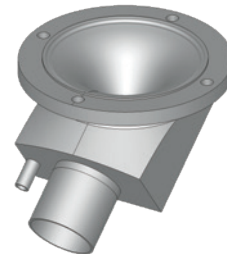
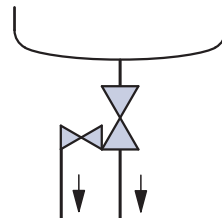

8)

### BU

1x Tank wall side sample valve  
 All previous position options are available with the tank side sample valve.  
 Machined welding pad to match the radius of the tank diameter.

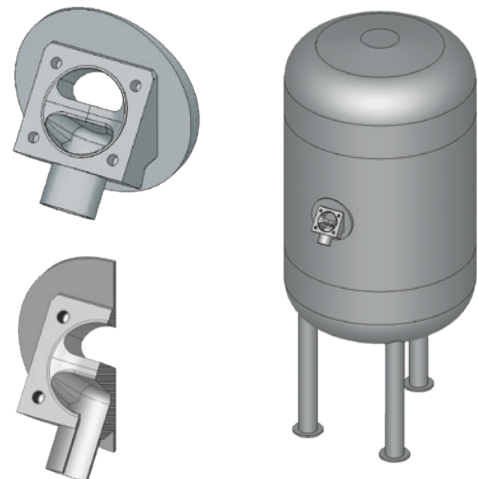
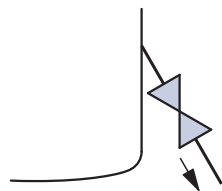

## Sterile Sampling Unit

The sampling unit is suitable to take sterile samples from all liquids in aseptic processes i.e. High purity water, High purity steam, Fermentation processes, Parenteral drugs, etc.

Samples can be taken in a continuous process with pneumatic controlled diaphragm valves or typically as a system with manual valves and a handle bring the complete unit in the laboratory for analyzing the sample in sterile conditions.

### Advantages of the SED-Sterile Sampling Unit

- Integral valve unit directly mounted to the sampling bottle
- CIP/ SIP function in one single valve component
- Efficiency in sterilization direct from the point of use
- Autoclavable system
- Less heat transfer
- Compact design
- Material traceability available acc. to EN 10204 3.1
- Less weight

**The recommended number of sampling units needed in a plant to qualify the process and continue the cycle of taking samples is:**

- one unit in use for taking sample
- one unit in the cleaning
- one unit in the sterilization
- one unit for safety

Eventually more units are needed if the testing of a sample takes longer, the frequency is high, or the laboratory is far away or external from the sampling point. Depending on the process, the locations of taking samples (i.g. parenteral drugs) can be several hundreds.

There are many different valve requirements when specifying the procedure for taking samples. There are not only the valves on the sampling unit but there is also a need for a valve combination or valve block on the tank and for the condensate and CIP solution as shown on the P&ID.

For applicable designs as valve configurations see page 74, 75 and for multipoint valves see page 77-87.



Sampling bottle with manual valves and handle



Sampling bottle with pneumatic actuated valves

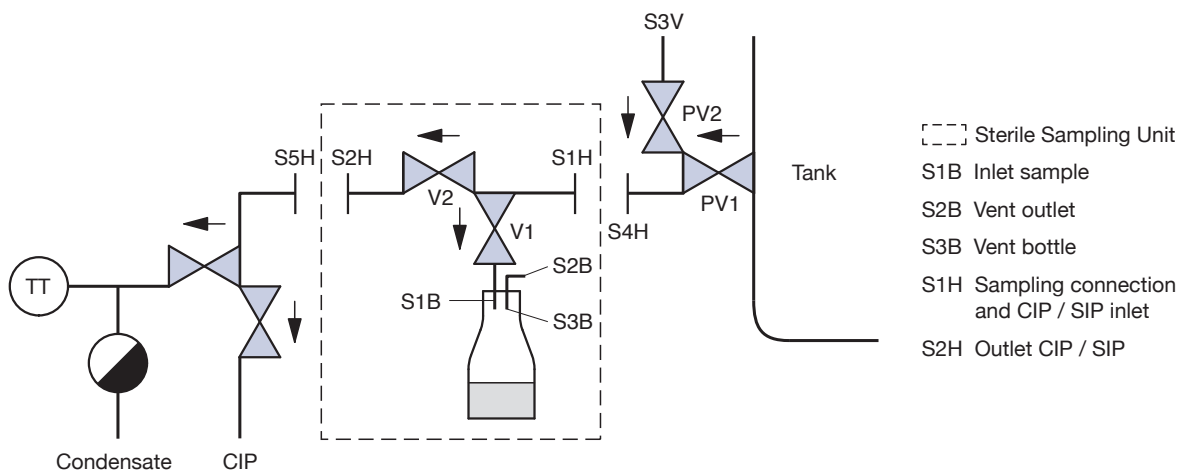

## Purified Steam Sampling Unit

The unit consists of a cooling coil with an integrated valve for sampling. Before taking a sample a simple sterilization of the unit is possible. By regulating the internal cooling circuit with the integrated diaphragm valve, the operator can control the temperature of the purified steam condensate. Also the diaphragm valve allows for shutting off the cooling circuit. All process connections are designed as butt weld or clamp end in order to integrate the unit easily into the process system as per customer request.

**Conforming to GMP the purified sampling unit may be permanently installed or for flexible mobile use.**

- Integrated diaphragm valve for sampling
- Unit easy to sterilize
- Minimized dead leg and completely self draining
- High grade stainless steel 1.4435/ 316L

### Features

- High condensation performance
- Time saving sampling
- Compact design
- Tube end or clamp end connection according specification
- Integrated sampling and control valve for cooling circuit
- Easy installation due to standardized compact unit
- Unit for mobile use

Cooling capacity: approx. 0,5 l/min<sup>1</sup> (132 gpm)  
 Condensate temperature: 30°C (86°F)  
 Max. pressure vessel: 10 bar (150 psi)  
 Max. pressure cooling helix: 10 to -0,9 bar (150 to -13 psi)  
 Max. temperature: 150°C (302°F)  
 Content cooling helix: 0,125 l (0,033 gallon)  
 Weight: 6,5 kg

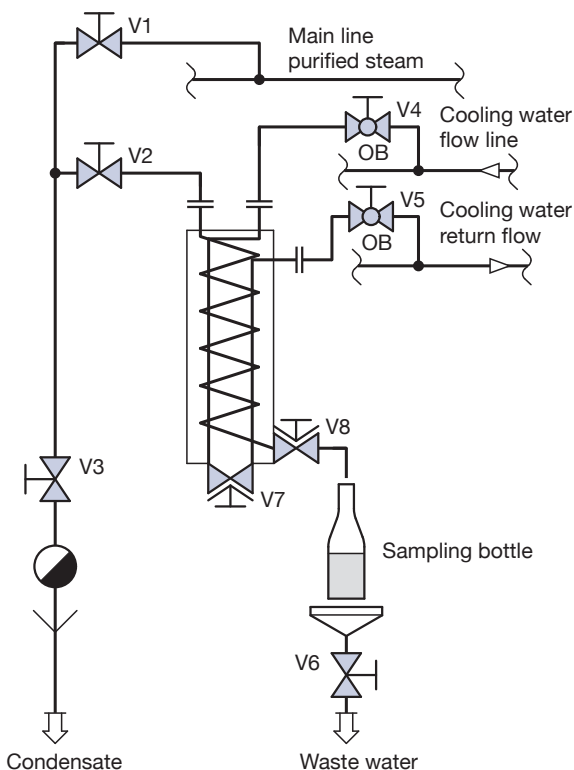
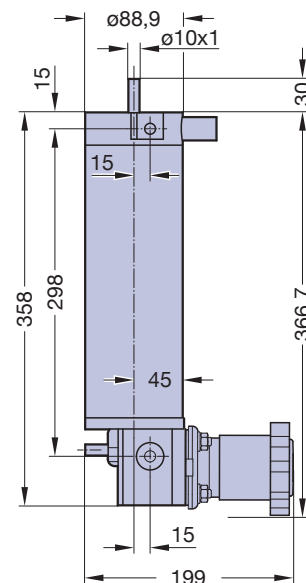
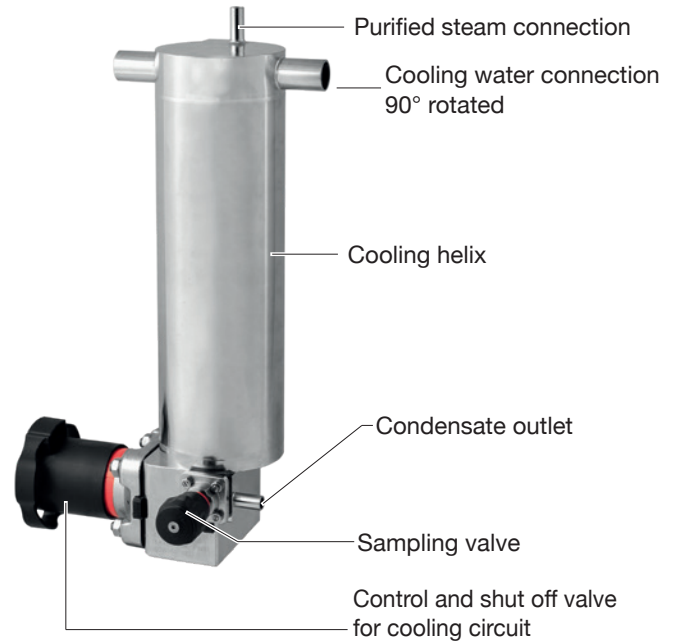

- V1** Shut off for main line purified steam
- V2** Shut off to purified sampling system
- V3** Shut off to steam trap
- V4** Shut off cooling water entering, valve blocked in open position
- V5** Shut off to cooling return flow, valve blocked in open position
- V6** Shut off to drainage
- V7** Diaphragm valve for shut off and regulating the cooling circuit within the unit
- V8** Diaphragm valve for condensate sampling

## Steripur 417 PM, manual pneumatically oversteerable DN 15 - 25 mm (3/4" - 1")

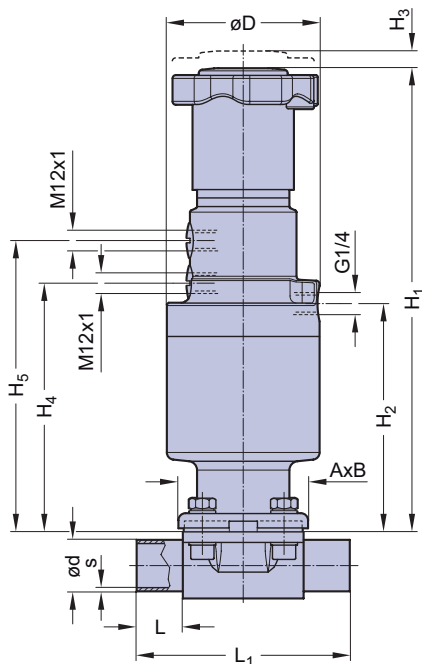
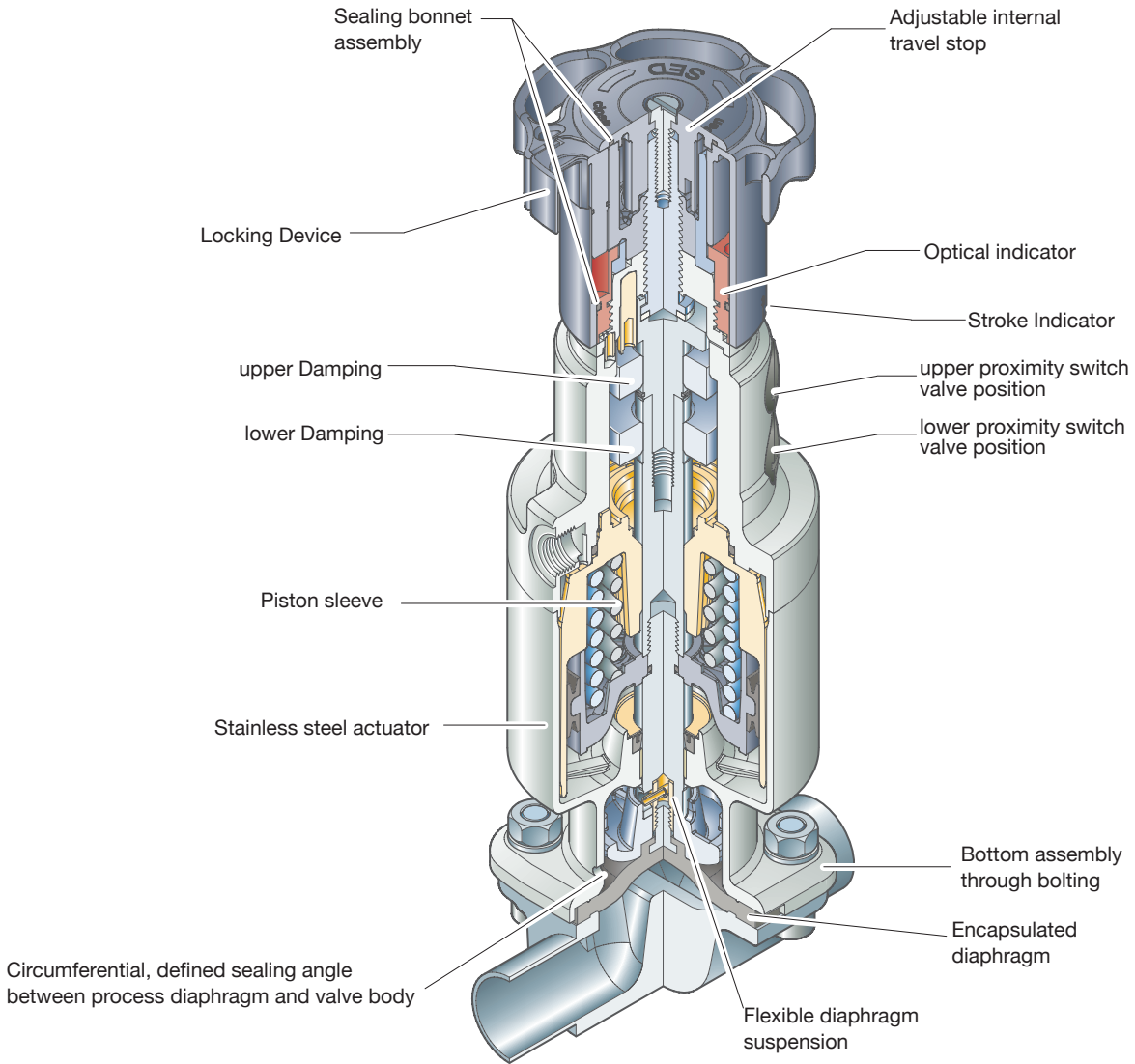

### Features

- Stainless steel actuator
- Compact design
- Advantages where space is limited
- Excellent design options for multiport valves
- Control air connection in flow direction or 90° to the flow direction
- CDSA sealing concept, see page 32
- Flexible diaphragm suspension
- Encapsulated diaphragm
- Clean and polished exterior design ideal for sterile wash downs

### Optional

- Integrated stroke limiter
- U-lock for handwheel
- Mounting of proximity sensors

Technical Data see page 42 and 43

| DN<br>(mm) | MA | Dimensions (mm) |     |     |    |     |     |         |    |     |    |     |
|------------|----|-----------------|-----|-----|----|-----|-----|---------|----|-----|----|-----|
|            |    | D               | H1  | H2  | H3 | H4  | H5  | A x B   | d  | s   | L  | L1  |
| 15-25      | 25 | 86              | 261 | 128 | 9  | 140 | 164 | 73 x 79 | 29 | 1,5 | 26 | 120 |



|          |   |  |
|----------|---|--|
| <b>1</b> | <b>Introduction</b><br>Overview   | Page<br>4 - 11   |
| <b>2</b> | <b>Media Contacted Components</b><br>Diaphragms<br>Valve Bodies (fold out page)<br>Butt Weld Tube Ends (fold out page)<br><b>Aseptic Connections</b>  | 14 - 19<br>20<br>21<br><b>22 - 24</b>  |
| <b>3</b> | <b>Aseptic Diaphragm Valves</b><br><b>Overview Diaphragm Aseptic Valves</b><br>Why Aseptic Diaphragm Valve?<br>Self Draining - Two-Way Valve<br>Innovative Design<br><b>Aseptic Diaphragm Valves</b><br>STERIPUR Series<br>KMA Series<br>KMD Series<br><b>Ordering Key and Ordering Example</b>   | 26, 27<br>28<br>29<br>30 - 33<br>34 - 46<br>48 - 58<br>60 - 65<br>66 - 68        |
| <b>4</b> | <b>Aseptic Diaphragm Valve Configurations</b><br><b>D-Rule</b><br><b>Welded Valve Configurations</b><br><b>Multiport Valves</b><br>Why Multiport Valves?<br>Main line open, Loop Valves (e.g. T-Valve)<br>All lines and valve ports able to close<br>The way of customized multiport valve designs<br>Specification Multiport Valves<br><b>Tank Valves</b><br><b>Process Solutions</b><br>Sterile Sampling Unit<br>Purified Steam Sampling Unit | 72<br>73 - 75<br>76<br>77 - 81<br>82 - 87<br>88<br>89<br>90 - 93<br>94<br>95     |
| <b>5</b> | <b>Angle Seat Valves</b><br>Description and Features<br>Technical Data<br>Regulating cone<br>2/2-Way Angle Seat Valves<br>Valve Body Dimensions<br>Ordering Key and Ordering Example  | 98, 99<br>100 - 101<br>102 - 105<br>106 - 114<br>115 - 117<br>118, 119           |
| <b>6</b> | <b>Ball Valves</b><br>Manual Ball Valve Description and Features<br>Pneumatically Ball Valve Description and Features<br>Technical Data<br>Ordering Key   | 123<br>124<br>125 - 128<br>129   |
| <b>7</b> | <b>System Components and Process Automation</b><br><b>Overview</b><br>Manual Adjustment - Optical Indication<br>Electrical Switch Boxes - Pilot Control<br><b>Detailed Information</b><br>3/2 Way Plastic Pilot Valve<br>Control Head Switch 024.63. - 024.89.<br>Contact-Free Limit Switch 024.50<br><b>Process Automation, Electropneumatic Positioners</b><br><b>Overview Product Range</b><br><b>Glossary</b>                               | 132<br>133<br>134<br>135, 136<br>137<br>138, 139<br>140 - 143<br>144<br>145, 146 |



The SED Angle Seat Valve is composed of a 2/2-way angle seat valve body and a pneumatically operated piston actuator, which is mounted with a stainless steel adaption to the valve body. Depending on the size, the actuators are made of plastic or aluminium. The plastic actuators consist of a high temperature resistant plastic. A self-adjusting gland assures reliable longlife performance. The gland is protected against dust and damage by a wiper, which is located in front of the gland. The SED Angle Seat Valve is suitable for shut off, dosing, control and regulating liquid or gaseous media.

The angle seat valve can be designed to specific requirements. Applications engineered for optimized flow characteristics is achieved by reduced Kv/Cv-values and equal percentage or linear flow curves. Even simple solutions like noise reduction are possible.

### Features

- High flow rate.
- Assembly of actuator is isolated from the media with sealing prior to the thread.
- 360° adjustable actuator orientation.
- Comprehensive modular accessories suitable for retrofitting after installation.
- Actuator options include normally closed, normally open, or double acting.
- Variety of valve body end connections including threaded socket, butt weld and socket weld in different international standards, flanged ends and sanitary clamps.

**Industries, applications, and media where the SED seat valves may be used.**

**Industry:**

Pharmaceutical, medical, food, beverage, cosmetics, chemical, packaging, plastic, rubber, textile and color industry.

**Applications:**

Sterilization in CIP and SIP, autoclave, steam generation, washing and cleaning facilities, filling, cooling circuits, heating facilities, boiler construction, dosing, packaging, drying, temperature and pressure control and process flow.

**Media:**

Steam, water, cooling water, gases, nitrate, compressed air, oils and various chemicals.

Multiport valve for the control and shut off of heating or cooling media, heating of fermentation units and batch boilers.

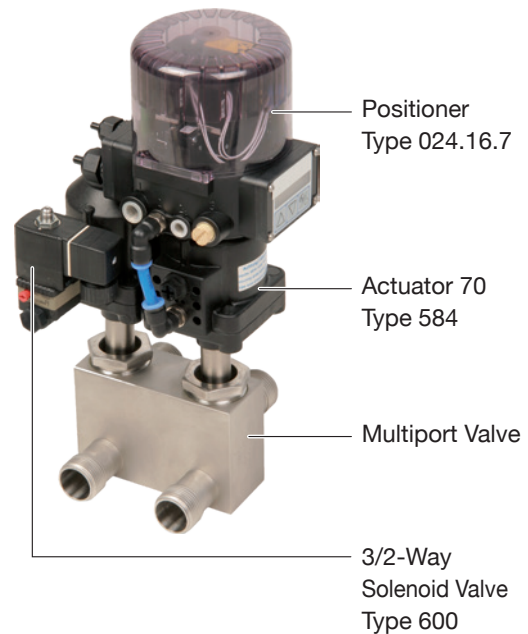

2/2-way angle seat valves with two stage actuator, adjustable stroke limiter, AS-Interface and circumferential optical position indicator, used for the filling of production containers with weighing equipment.

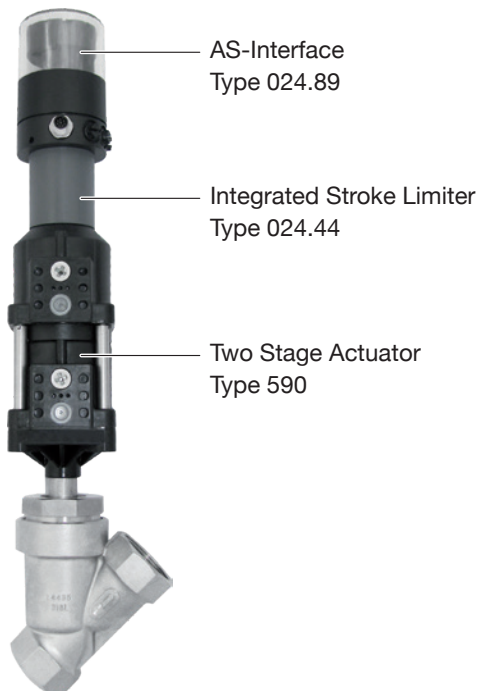

Bioreactor from Solaris biotechnology with SED 2/2-Way Angle Seat Valves for purified steam and diaphragm valves for aseptic media.





# Technical Data

## Operating Conditions

|                      |  |                      |  |
|----------------------|--|----------------------|--|
| Operating Medium:    | Neutral, aggressive, gaseous, and liquid media. Media must be compatible with the materials of construction. | Size:                | DN 8-80  |
| Viscosity:           | Max. 600 mm <sup>2</sup> /sec  | Valve Body Material: | See ordering key page 118, 119   |
| Medium Temperature:  | -10 to +180°C for PTFE sealing   | Sealing:             | PTFE capsuled (NBR, FKM, EPDM on request)  |
| Working Pressure:    | See table  | Actuator Material:   | See ordering key page 118, 119   |
| Control Medium:      | Neutral gases, air   | Filling Volume:      | Actuator 43, 45, 46 0,03 dm <sup>3</sup><br>Actuator 70/71 0,13 dm <sup>3</sup><br>Actuator 125 0,63 dm <sup>3</sup> |
| Temperature          |  |                      |  |
| Control Medium:      | Max. +80°C   |                      |  |
| Working Temperature: | -10 to +90°C   |                      |  |

### Kv-Value Water (m<sup>3</sup>/h)

| Size   | 8   | 10       | 15  | 15            | 20                 | 25                 | 32            | 40                 | 50                 | 65       | 65            | 80            |
|--|-----|----------|-----|---------------|--------------------|--------------------|---------------|--------------------|--------------------|----------|---------------|---------------|
| End connection Code                            |     |          |     |               |                    |                    |               |                    |                    |          |               |               |
| Threaded socket                                | -   | -        | -   | 1,1N          | 1,1N               | 1,1N               | 1             | 1,1N               | 1,1N               | -        | 1,1N          | -             |
| Butt weld ends                                 | 40  | 41, 42   | 45  | 40, 41, 42    | 40, 41, 42, 45     | 40, 41, 42, 45, 49 | 40, 41, 42    | 40, 41, 42, 45, 49 | 40, 41, 42, 45, 49 | 45, 49   | 40, 42        | 40, 45, 49    |
| Clamp ends                                     | 740 | 741, 742 | 745 | 740, 741, 742 | 740, 741, 742, 745 | 740, 741, 742, 745 | 740, 741, 742 | 740, 741, 742, 745 | 740, 741, 742, 745 | 745, 749 | 740, 741, 742 | 740, 745, 749 |
| Flange   | -   | -        | -   | 51            | 51                 | 51                 | 51            | 51                 | 51                 | -        | 51            | 51            |
| Kv-Value actuator type code 43                 | 2,1 | 2,4      | 2,4 |               |                    |                    |               |                    |                    |          |               |               |
| Kv-Value for all actuator types except code 43 |     |          |     | 5,2           | 10,0               | 15,0               | 22,5          | 40,0               | 72,0               | 72,0     | 105,0         | 105,0         |

Measuring at 20°C, 1 bar pressure at the valve input and the free outlet, measured at the valve body with threaded socket.

### Kv-Value Water (m<sup>3</sup>/h), end connection code 545

| Size   | 15  | 20  | 25 | 40 | 50 | 65 |
|--|-----|-----|----|----|----|----|
| Kv-Value for all actuator types except code 43 | 2,1 | 4,5 | 10 | 23 | 34 | 35 |

# Technical Data



| Working Pressure for Valves with flow <b>below</b> the seat, all end connections except code 545 |         |                      |                              |  |                             |    |    |     |    |     |    |    |    |
|--|---------|----------------------|------------------------------|--|-----------------------------|----|----|-----|----|-----|----|----|----|
| Actuator Type<br>Code  | Type    | Ø Actuator<br>Piston | Control<br>Function<br>(Cf.) | Control Pressure<br>min. - max.<br>(bar) | Size                        |    |    |     |    |     |    |    |    |
|  |         |                      |                              |  | 8-15                        | 15 | 20 | 25  | 32 | 40  | 50 | 65 | 80 |
|  |         |                      |                              |  | Working Pressure max. (bar) |    |    |     |    |     |    |    |    |
|  | 580     |                      | Manually op.                 |  |                             | 16 | 16 | 16  | 10 | 10  | 10 |    |    |
|  | 581     |                      | Manually op.                 |  |                             | 10 | 10 | 10  | 10 | 10  | 10 |    |    |
| 43   | 584     | 45                   | 1 (NC)                       | 4,5-7                                    | 16                          |    |    |     |    |     |    |    |    |
| 45   | 584     | 45                   | 1 (NC)                       | 4,5-7                                    |                             | 11 | 6  | 2,5 |    |     |    |    |    |
| 70   | 584/590 | 70                   | 1 (NC)                       | 4,5-7                                    |                             | 25 | 20 | 10  | 7  | 4,5 | 3  |    |    |
| 70   | 582     | 70                   | 1 (NC)                       | 4,5-7                                    |                             | 10 | 10 | 10  |    |     |    |    |    |
| 125  | 582     | 125                  | 1 (NC)                       | 4,5-7                                    |                             |    |    |     | 10 | 10  | 10 | 10 |    |
| 125  | 584     | 125                  | 1 (NC)                       | 4,5-7                                    |                             |    | 25 | 25  | 25 | 20  | 15 | 10 | 7  |
| 43   | 584     | 45                   | 2 (NO)                       | page 106                                 | 25                          |    |    |     |    |     |    |    |    |
| 45   | 584     | 45                   | 2 (NO)                       | page 107                                 |                             | 25 | 22 | 14  |    |     |    |    |    |
| 70   | 584     | 70                   | 2 (NO)                       | page 108                                 |                             | 25 | 25 | 25  | 25 | 16  | 11 |    |    |
| 70   | 582     | 70                   | 2 (NO)                       | max. 7                                   |                             | 10 | 10 | 10  |    |     |    |    |    |
| 125  | 582     | 125                  | 2 (NO)                       | max. 7                                   |                             |    |    |     | 10 | 10  | 10 | 10 |    |
| 125  | 584     | 125                  | 2 (NO)                       | page 109                                 |                             |    | 25 | 25  | 25 | 25  | 25 | 22 | 16 |
| 43   | 584     | 45                   | 3 (DA)                       | page 106                                 | 25                          |    |    |     |    |     |    |    |    |
| 45   | 584     | 45                   | 3 (DA)                       | page 107                                 |                             | 25 | 25 | 20  |    |     |    |    |    |
| 70   | 584     | 70                   | 3 (DA)                       | page 108                                 |                             | 25 | 25 | 25  | 25 | 17  | 11 |    |    |
| 125  | 584     | 125                  | 3 (DA)                       | page 109                                 |                             |    | 25 | 25  | 25 | 25  | 25 | 22 | 16 |

| Working Pressure for Valves with flow <b>below</b> the seat, end connection code 545 |      |                      |                              |  |                             |    |    |    |    |    |
|--|------|----------------------|------------------------------|--|-----------------------------|----|----|----|----|----|
| Actuator Type<br>Code  | Type | Ø Actuator<br>Piston | Control<br>Function<br>(Cf.) | Control Pressure<br>min. - max.<br>(bar) | Size                        |    |    |    |    |    |
|  |      |                      |                              |  | 15                          | 20 | 25 | 40 | 50 | 65 |
|  |      |                      |                              |  | Working Pressure max. (bar) |    |    |    |    |    |
| 70   | 584  | 70                   | 1 (NC)                       | 4,5-7                                    | 25                          | 25 | 20 | 7  | 5  | 3  |
| 70   | 584  | 70                   | 2 (NO)                       | page 108                                 | 25                          | 25 | 25 | 20 | 12 | 8  |
| 70   | 584  | 70                   | 3 (DA)                       | page 108                                 | 25                          | 25 | 25 | 20 | 12 | 8  |

| Working Pressure for Valves with flow <b>above</b> the seat (suitable to only a limited extent for liquid media, there is a danger of waterhammer) |      |                      |                              |  |                             |    |    |    |    |    |    |    |    |
|--|------|----------------------|------------------------------|--|-----------------------------|----|----|----|----|----|----|----|----|
| Actuator Type<br>Code  | Type | Ø Actuator<br>Piston | Control<br>Function<br>(Cf.) | Control Pressure<br>min. - max.<br>(bar) | Size                        |    |    |    |    |    |    |    |    |
|  |      |                      |                              |  | 8-15                        | 15 | 20 | 25 | 32 | 40 | 50 | 65 | 80 |
|  |      |                      |                              |  | Working Pressure max. (bar) |    |    |    |    |    |    |    |    |
| 46   | 584  | 45                   | 1 (NC)                       | page 107                                 |                             | 10 | 10 | 10 |    |    |    |    |    |
| 71   | 584  | 70                   | 1 (NC)                       | page 108                                 |                             | 10 | 10 | 10 | 10 | 10 | 10 |    |    |

All pressures are gauge pressures.



# Technical Data Regulating Cone

Kv value Correlation, operating pressure, regulating match code 42, 742  
Valve body material: 1.4404 (code 7A)

| Nominal size<br>DN | Kv-value<br>[m³/h] | Operating pressure (NC)<br>[bar] | Actuator size | Regulating article number |                         |
|--------------------|--------------------|----------------------------------|---------------|---------------------------|-------------------------|
|                    |                    |                                  |               | linear                    | equal-percentage (mod.) |
| 15                 | 0,10 **            | 25                               | 70            | ALA15                     | APA15                   |
|                    | 0,16 **            | 25                               | 70            | ALB15                     | APB15                   |
|                    | 0,25 **            | 25                               | 70            | ALC15                     | APC15                   |
|                    | 0,40 **            | 25                               | 70            | ALD15                     | APD15                   |
|                    | 0,63 **            | 25                               | 70            | ALE15                     | APE15                   |
|                    | 1,00 **            | 25                               | 70            | ALF15                     | APF15                   |
|                    | 1,60               | 25                               | 70            | ALG15                     | APG15                   |
|                    | 2,50               | 25                               | 70            | ALH15                     | APH15                   |
| 20                 | 1,60               | 20                               | 70            | ALA20                     | APA20                   |
|                    | 2,50               | 20                               | 70            | ALB20                     | APB20                   |
|                    | 4,00               | 20                               | 70            | ALC20                     | APC20                   |
|                    | 6,30               | 20                               | 70            | ALD20                     | APD20                   |
| 25                 | 2,50               | 10                               | 70            | ALA25                     | APA25                   |
|                    | 4,00               | 10                               | 70            | ALB25                     | APB25                   |
|                    | 6,30               | 10                               | 70            | ALC25                     | APC25                   |
|                    | 10,00              | 10                               | 70            | ALD25                     | APD25                   |
| 32                 | 4,00               | 7                                | 70            | ALA32                     | APA32                   |
|                    | 6,30               | 7                                | 70            | ALB32                     | APB32                   |
|                    | 10,00              | 7                                | 70            | ALC32                     | APC32                   |
|                    | 16,00              | 7                                | 70            | ALD32                     | APD32                   |
| 40                 | 6,30               | 4,5                              | 70            | ALA40                     | APA40                   |
|                    | 10,00              | 4,5                              | 70            | ALB40                     | APB40                   |
|                    | 16,00              | 4,5                              | 70            | ALC40                     | APC40                   |
|                    | 25,00              | 20                               | 125           | ALD40                     | APD40                   |
| 50                 | 10,00              | 3                                | 70            | ALA50                     | APA50                   |
|                    | 16,00              | 3                                | 70            | ALB50                     | APB50                   |
|                    | 25,00              | 15                               | 125           | ALC50                     | APC50                   |
|                    | 40,00              | 15                               | 125           | ALD50                     | APD50                   |

\*\*Metal-seated

# Technical Data Regulating Cone



Kv value Correlation, operating pressure, regulating match code 40, 740  
Valve body material: 1.4404 (code 7A)

| Nominal size<br>DN | Kv-value<br>[m³/h] | Operating pressure (NC)<br>[bar] | Actuator size | Regulating article number |                         |
|--------------------|--------------------|----------------------------------|---------------|---------------------------|-------------------------|
|                    |                    |                                  |               | linear                    | equal-percentage (mod.) |
| 15                 | 0,10 **            | 25                               | 70            | BLA15                     | BPA15                   |
|                    | 0,16 **            | 25                               | 70            | BLB15                     | BPB15                   |
|                    | 0,25 **            | 25                               | 70            | BLC15                     | BPC15                   |
|                    | 0,40 **            | 25                               | 70            | BLD15                     | BPD15                   |
|                    | 0,63 **            | 25                               | 70            | BLE15                     | BPE15                   |
|                    | 1,00 **            | 25                               | 70            | BLF15                     | BPF15                   |
|                    | 1,60               | 25                               | 70            | BLG15                     | BPG15                   |
|                    | 2,50               | 25                               | 70            | BLH15                     | BPH15                   |
| 20                 | 1,60               | 20                               | 70            | BLA20                     | BPA20                   |
|                    | 2,50               | 20                               | 70            | BLB20                     | BPB20                   |
|                    | 4,00               | 20                               | 70            | BLC20                     | BPC20                   |
|                    | 6,30               | 20                               | 70            | BLD20                     | BPD20                   |
| 25                 | 2,50               | 10                               | 70            | BLA25                     | BPA25                   |
|                    | 4,00               | 10                               | 70            | BLB25                     | BPB25                   |
|                    | 6,30               | 10                               | 70            | BLC25                     | BPC25                   |
|                    | 10,00              | 10                               | 70            | BLD25                     | BPD25                   |
| 32                 | 4,00               | 7                                | 70            | BLA32                     | BPA32                   |
|                    | 6,30               | 7                                | 70            | BLB32                     | BPB32                   |
|                    | 10,00              | 7                                | 70            | BLC32                     | BPC32                   |
|                    | 16,00              | 7                                | 70            | BLD32                     | BPD32                   |
| 40                 | 6,30               | 4,5                              | 70            | BLA40                     | BPA40                   |
|                    | 10,00              | 4,5                              | 70            | BLB40                     | BPB40                   |
|                    | 16,00              | 4,5                              | 70            | BLC40                     | BPC40                   |
|                    | 25,00              | 20                               | 125           | BLD40                     | BPD40                   |
| 50                 | 10,00              | 3                                | 70            | BLA50                     | BPA50                   |
|                    | 16,00              | 3                                | 70            | BLB50                     | BPB50                   |
|                    | 25,00              | 15                               | 125           | BLC50                     | BPC50                   |
|                    | 40,00              | 15                               | 125           | BLD50                     | BPD50                   |

\*\*Metal-seated



# Technical Data Regulating Cone

Kv value Correlation, operating pressure, regulating match code 45  
Valve body material: 1.4404 (code 7A)

| Nominal size<br>DN | Kv-value<br>[m³/h] | Operating pressure (NC)<br>[bar] | Actuator size | Regulating article number |                         |
|--------------------|--------------------|----------------------------------|---------------|---------------------------|-------------------------|
|                    |                    |                                  |               | linear                    | equal-percentage (mod.) |
| 15                 | 0,10 **            | 25                               | 70            | CLA15                     | CPA15                   |
|                    | 0,16 **            | 25                               | 70            | CLB15                     | CPB15                   |
|                    | 0,25 **            | 25                               | 70            | CLC15                     | CPC15                   |
|                    | 0,40 **            | 25                               | 70            | CLD15                     | CPD15                   |
|                    | 0,63 **            | 25                               | 70            | CLE15                     | CPE15                   |
|                    | 1,00 **            | 25                               | 70            | CLF15                     | CPF15                   |
|                    | 1,60               | 25                               | 70            | CLG15                     | CPG15                   |
|                    | 2,50               | 25                               | 70            | CLH15                     | CPH15                   |
| 20                 | 1,60               | 20                               | 70            | CLA20                     | CPA20                   |
|                    | 2,50               | 20                               | 70            | CLB20                     | CPB20                   |
|                    | 4,00               | 20                               | 70            | CLC20                     | CPC20                   |
|                    | 6,30               | 20                               | 70            | CLD20                     | CPD20                   |
| 25                 | 2,50               | 10                               | 70            | CLA25                     | CPA25                   |
|                    | 4,00               | 10                               | 70            | CLB25                     | CPB25                   |
|                    | 6,30               | 10                               | 70            | CLC25                     | CPC25                   |
|                    | 10,00              | 10                               | 70            | CLD25                     | CPD25                   |
| 32                 | 4,00               | 7                                | 70            | CLA32                     | CPA32                   |
|                    | 6,30               | 7                                | 70            | CLB32                     | CPB32                   |
|                    | 10,00              | 7                                | 70            | CLC32                     | CPC32                   |
|                    | 16,00              | 7                                | 70            | CLD32                     | CPD32                   |
| 40                 | 6,30               | 4,5                              | 70            | CLA40                     | CPA40                   |
|                    | 10,00              | 4,5                              | 70            | CLB40                     | CPB40                   |
|                    | 16,00              | 4,5                              | 70            | CLC40                     | CPC40                   |
|                    | 25,00              | 20                               | 125           | CLD40                     | CPD40                   |
| 50                 | 10,00              | 3                                | 70            | CLA50                     | CPA50                   |
|                    | 16,00              | 3                                | 70            | CLB50                     | CPB50                   |
|                    | 25,00              | 15                               | 125           | CLC50                     | CPC50                   |
|                    | 40,00              | 15                               | 125           | CLD50                     | CPD50                   |

\*\*Metal-seated



# Technical Data Regulating Cone



Kv value Correlation, operating pressure, regulating match code 545  
Valve body material: 1.4435 (code 7)

| Nominal size<br>DN | Kv-value<br>[m³/h] | Operating pressure (NC)<br>[bar] | Actuator size | Regulating article number |                         |
|--------------------|--------------------|----------------------------------|---------------|---------------------------|-------------------------|
|                    |                    |                                  |               | linear                    | equal-percentage (mod.) |
| 15                 | 0,10 **            | 25                               | 70            | DLA15                     | DPA15                   |
|                    | 0,16 **            | 25                               | 70            | DLB15                     | DPB15                   |
|                    | 0,25 **            | 25                               | 70            | DLC15                     | DPC15                   |
|                    | 0,40 **            | 25                               | 70            | DLD15                     | DPD15                   |
|                    | 0,63 **            | 25                               | 70            | DLE15                     | DPE15                   |
|                    | 1,00 **            | 25                               | 70            | DLF15                     | DPF15                   |
|                    | 1,60               | 25                               | 70            | DLG15                     | DPG15                   |
|                    | 2,50               | 25                               | 70            | DLH15                     | DPH15                   |
| 20                 | 1,60               | 25                               | 70            | DLA20                     | DPA20                   |
|                    | 2,50               | 25                               | 70            | DLB20                     | DPB20                   |
|                    | 4,00               | 25                               | 70            | DLC20                     | DPC20                   |
| 25                 | 1,60               | 20                               | 70            | DLA25                     | DPA25                   |
|                    | 2,50               | 20                               | 70            | DLB25                     | DPB25                   |
|                    | 4,00               | 20                               | 70            | DLC25                     | DPC25                   |
|                    | 6,30               | 20                               | 70            | DLD25                     | DPD25                   |
|                    | 9,00               | 20                               | 70            | DLE25                     | DPE25                   |
| 40                 | 4,00               | 7                                | 70            | DLA40                     | DPA40                   |
|                    | 6,30               | 7                                | 70            | DLB40                     | DPB40                   |
|                    | 10,00              | 7                                | 70            | DLC40                     | DPC40                   |
|                    | 16,00              | 25                               | 125           | DLD40                     | DPD40                   |
|                    | 20,00              | 25                               | 125           | DLE40                     | DPE40                   |
| 50                 | 6,30               | 4,5                              | 70            | DLA50                     | DPA50                   |
|                    | 10,00              | 4,5                              | 70            | DLB50                     | DPB50                   |
|                    | 16,00              | 20                               | 125           | DLC50                     | DPC50                   |
|                    | 25,00              | 20                               | 125           | DLD50                     | DPD50                   |
|                    | 30,00              | 20                               | 125           | DLE50                     | DPE50                   |

\*\*Metal-seated

# Type 584, Actuator 43

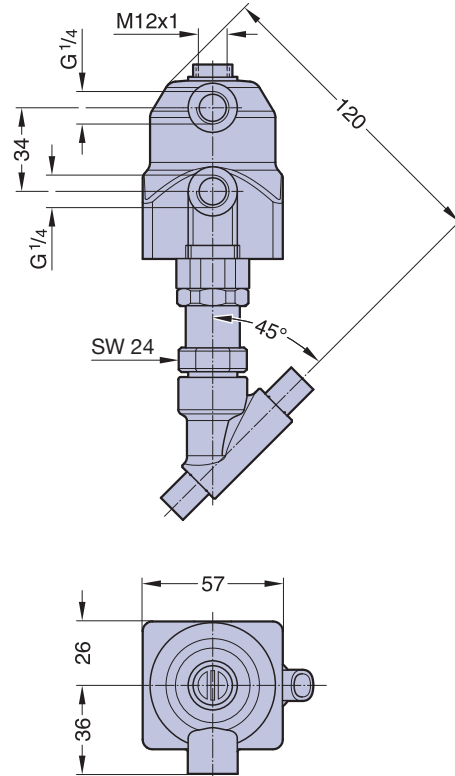

Weight ca. 0,7 kg

Valve body types see page 115 - 117

Control equipment and accessories see page 132 - 139

**Actuator 43 (NO), flow below the seat**

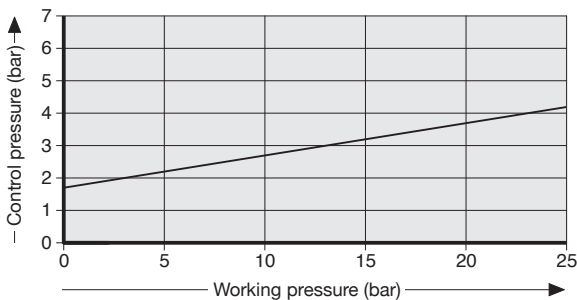

**Actuator 43 (DA), flow below the seat**

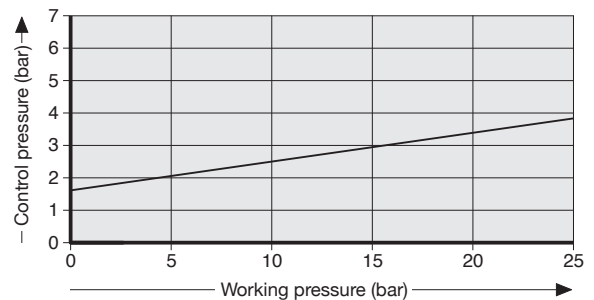

Working pressure normally closed (Cf. 1), flow below the seat as well as Working terms, see table page 101.  
All pressures are gauge pressures.

Ordering key and cut view see page 118 and 119.

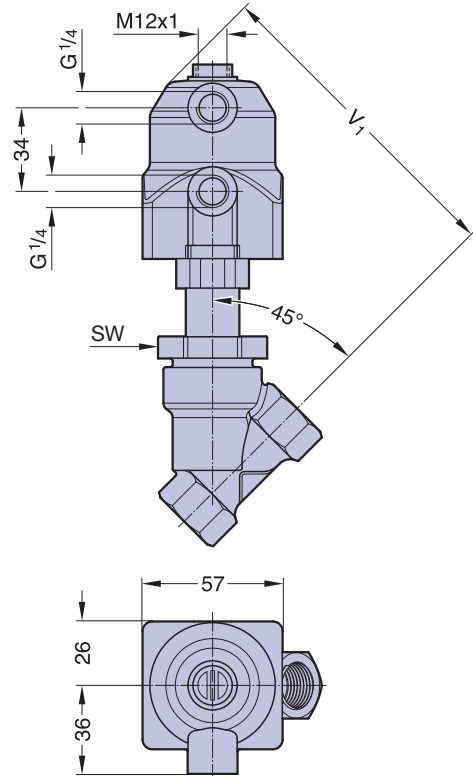

**Actuator 45 (NO), flow below the seat**

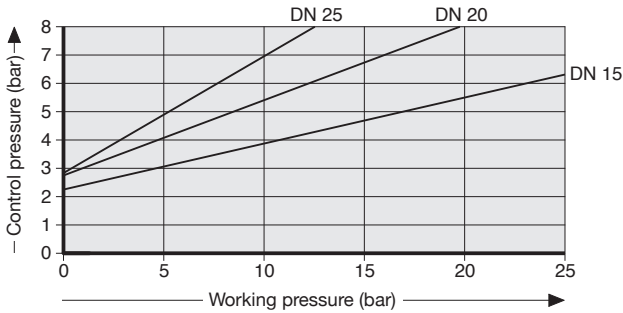

Measurement and weight table Actuator type 45 and 46

| DN | SW | V <sub>1</sub> | Total weight ca. (kg) |
|----|----|----------------|-----------------------|
| 15 | 36 | 130            | 0,8                   |
| 20 | 41 | 136            | 1,1                   |
| 25 | 46 | 140            | 1,2                   |

Valve body types see page 115 - 117

Control equipment and accessories see page 132 - 139

**Actuator 45 (DA), flow below the seat**

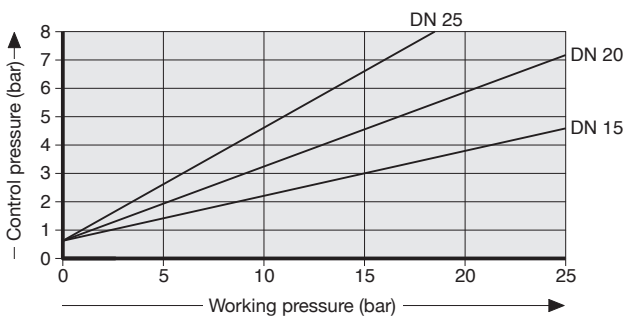

**Actuator 46 (NC), flow above the seat**

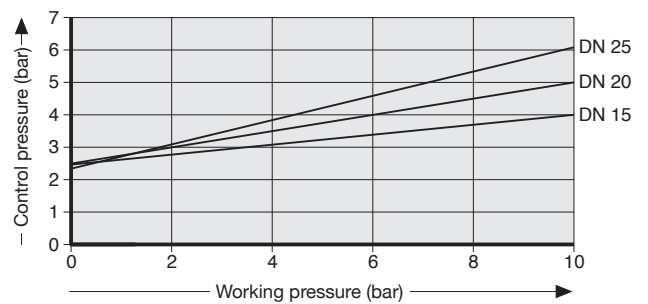

Working pressure normally closed (Cf. 1), flow below the seat as well as Working terms, see table page 101. All pressures are gauge pressures.

Ordering key and cut view see page 118 and 119.

# Type 584, Actuator 70 and Actuator 71



Namur-Flange  
The threaded  
bushing  
024.583.001 for  
the valve mount-  
ing necessary  
is available on  
request.

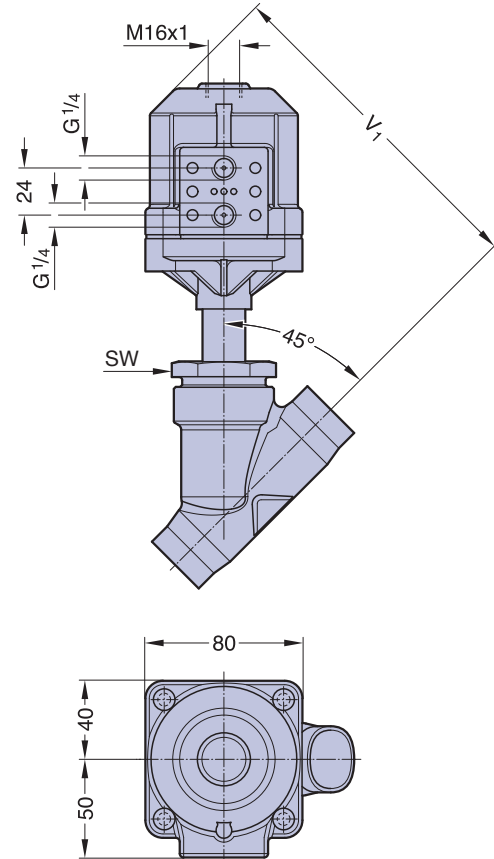

## Actuator 70 (NO), flow below the seat

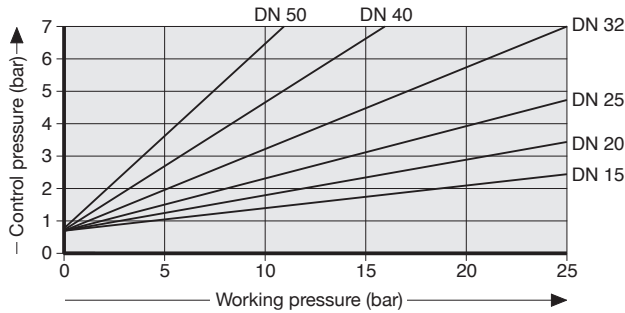

Measurement and weight table Actuator type 70 and 71

| DN | SW | V <sub>1</sub> | Total weight ca. (kg) |
|----|----|----------------|-----------------------|
| 15 | 36 | 162            | 1,2                   |
| 20 | 41 | 173            | 1,3                   |
| 25 | 46 | 173            | 1,6                   |
| 32 | 55 | 179            | 2,1                   |
| 40 | 60 | 185            | 2,2                   |
| 50 | 75 | 192            | 3,2                   |

Valve body types see page 115 - 117

Control equipment and accessories see page 132 - 139

## Actuator 70 (DA), flow below the seat

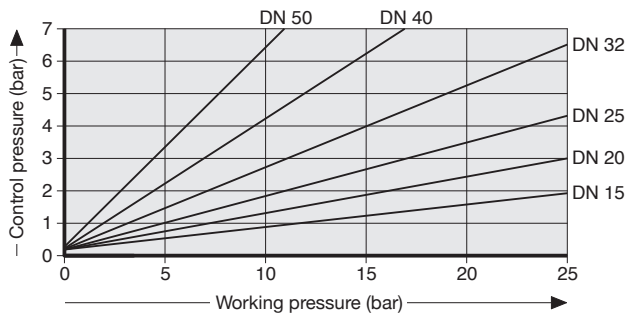

## Actuator 71 (NC), flow above the seat

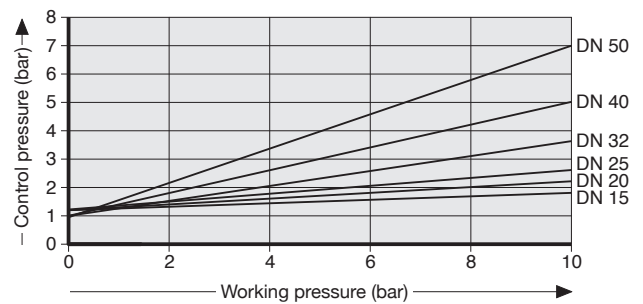

Working pressure normally closed (Cf. 1), flow below the seat as well as Working terms, see table page 101.  
All pressures are gauge pressures.

Ordering key and cut view see page 118 and 119.

# Type 584, Actuator 125

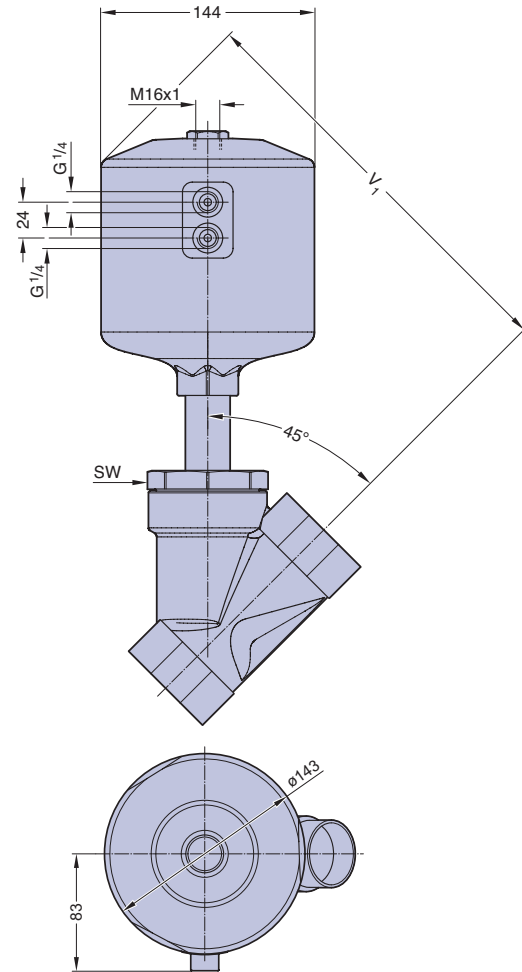

| DN | SW | V <sub>1</sub> | Total weight ca. (kg) |
|----|----|----------------|-----------------------|
| 20 | 41 | 258            | 3,7                   |
| 25 | 46 | 263            | 3,9                   |
| 32 | 55 | 269            | 4,4                   |
| 40 | 60 | 274            | 4,9                   |
| 50 | 75 | 282            | 5,9                   |
| 65 | 75 | 295            | 7,8                   |

Valve body types see page 115 - 117  
Control equipment and accessories see page 132 - 139

**Actuator 125 (NO), flow below the seat**

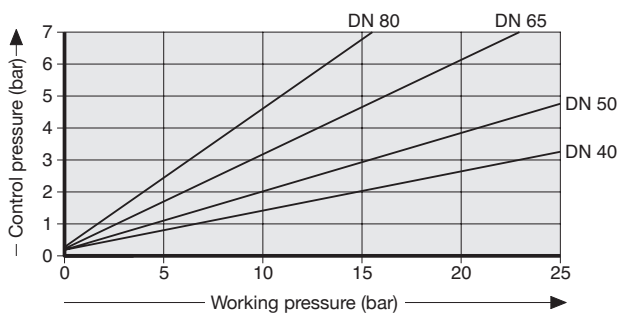

**Actuator 125 (DA), flow below the seat**

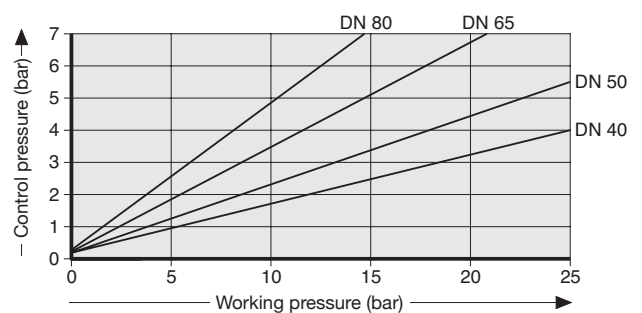

Working pressure normally closed (Cf. 1), flow below the seat as well as Working terms, see table page 101.  
All pressures are gauge pressures.

Ordering key and cut view see page 118 and 119.

# Type 582, Actuator 70

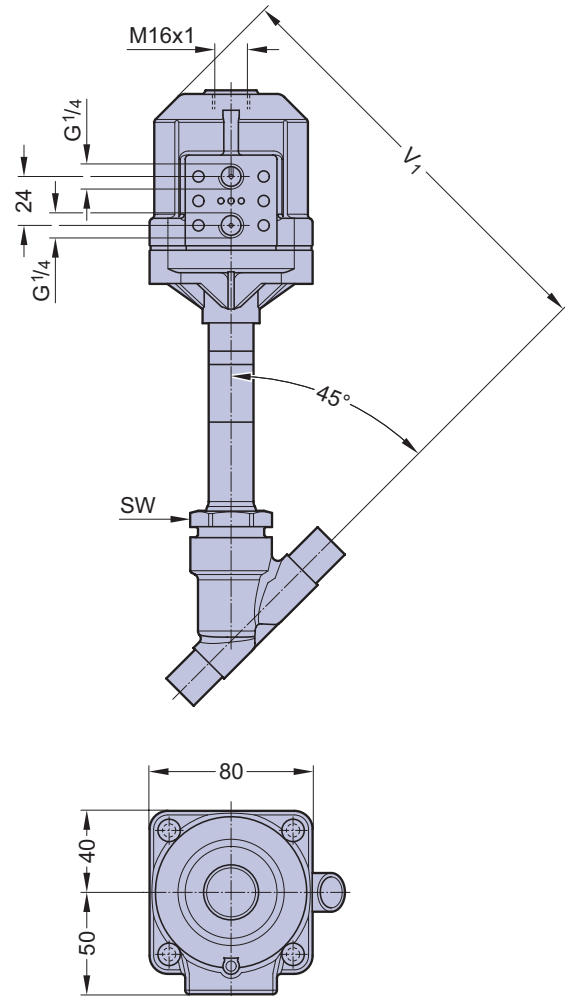

### Advantages:

- Hygienic design, easy cleaning
- High temperature resistance
- Stainless steel below
- Minimized dead leg design
- Easy maintenance
- Good regulation properties
- Clean and smooth exterior for sterile washdowns
- Regulating cone

### Specific application:

- Pure or clean steam and gaseous media

| DN | SW | V <sub>1</sub> | Total weight ca. (kg) |
|----|----|----------------|-----------------------|
| 15 | 36 | 209            | 1,8                   |
| 20 | 41 | 209            | 2,2                   |
| 25 | 46 | 209            | 2,8                   |

Valve body types see page 115 - 117

Control equipment and accessories see page 132 - 139

Ordering key see page 118 and 119.

# Type 582, Actuator 125

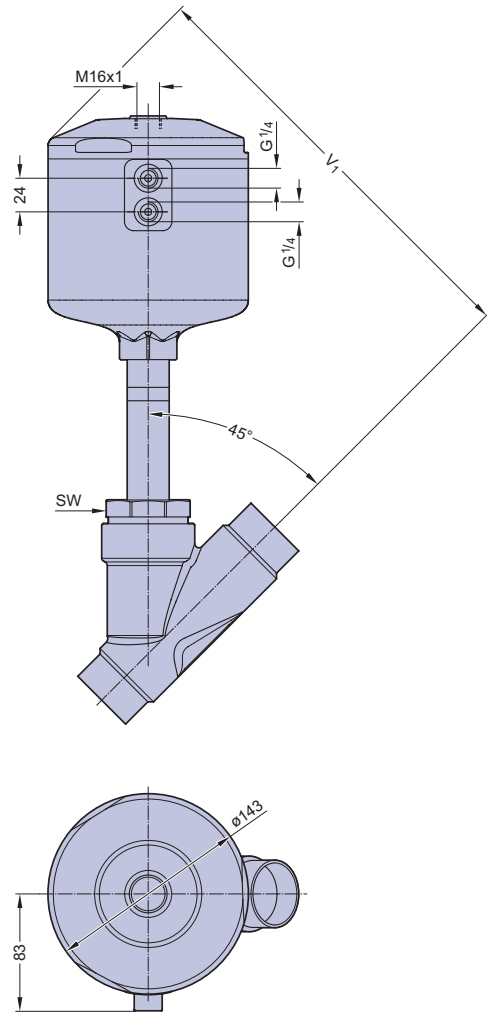

## Advantages:

- Hygienic design, easy cleaning
- High temperature resistance
- Stainless steel below
- Minimized dead leg design
- Easy maintenance
- Good regulation properties
- Clean and smooth exterior for sterile washdowns
- Regulating cone

## Specific application:

- Pure or clean steam and gaseous media

Measurement and weight table Actuator type 125

| DN | SW | V <sub>1</sub> | Total weight ca. (kg) |
|----|----|----------------|-----------------------|
| 32 | 55 | 310            | 5,9                   |
| 40 | 60 | 309            | 7,0                   |
| 50 | 75 | 309            | 9,0                   |
| 65 | 75 | 311            | 13,6                  |

Valve body types see page 115 - 117

Control equipment and accessories see page 132 - 139

Ordering key see page 118 and 119.

# Type 590, Two Stage Actuator 70

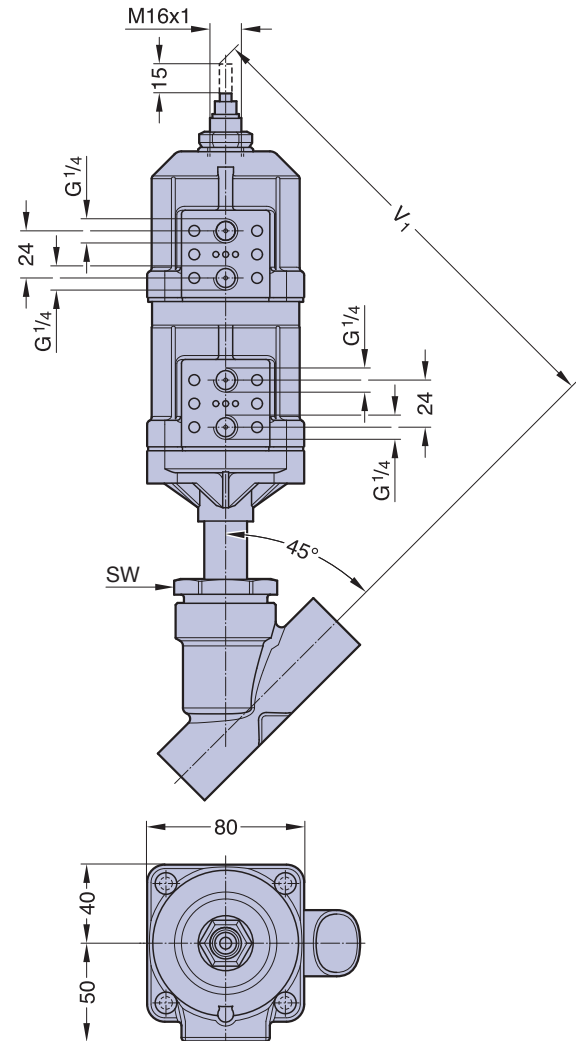

## 2/2-Way Angle Seat Valves with Two Stage Actuator

The pneumatically controlled two stage piston actuator is made of two plastic actuators. The two stages can be independently actuated from each other. In order to open the valve completely with the full flowrate, the lower piston has to be actuated. Limited opening or flowrate is possible by actuating the upper piston. An adjustable stroke limiter allows to adjust the linear movement of the upper position. An optical indicator which is directly connected with the valve spindle shows the stroke. The control function of the valve is normally closed (Cf.1).

### Application

The valve is mainly used for filling with controlled filling of a tank, container or barrel. For filling, the valve is completely opened with the full flow rate. At the end of the filling cycle, the valve automatically reduces to the second stage of filling with a reduced flow rate for an accurate finish fill.

Measurement and weight table Actuator type 70

| DN | SW | V <sub>1</sub> | Total weight ca. (kg) |
|----|----|----------------|-----------------------|
| 15 | 36 | 232            | 1,9                   |
| 20 | 41 | 238            | 2,1                   |
| 25 | 46 | 243            | 2,2                   |
| 32 | 55 | 249            | 2,9                   |
| 40 | 60 | 255            | 3                     |
| 50 | 75 | 263            | 4                     |

Valve body types see page 115 - 117

Control equipment and accessories see page 132 - 139

Working pressure normally closed (Cf. 1), flow below the seat as well as Working terms, see table page 101. All pressures are gauge pressures.

Ordering key see page 118 and 119.



# Type 580, Manually operated

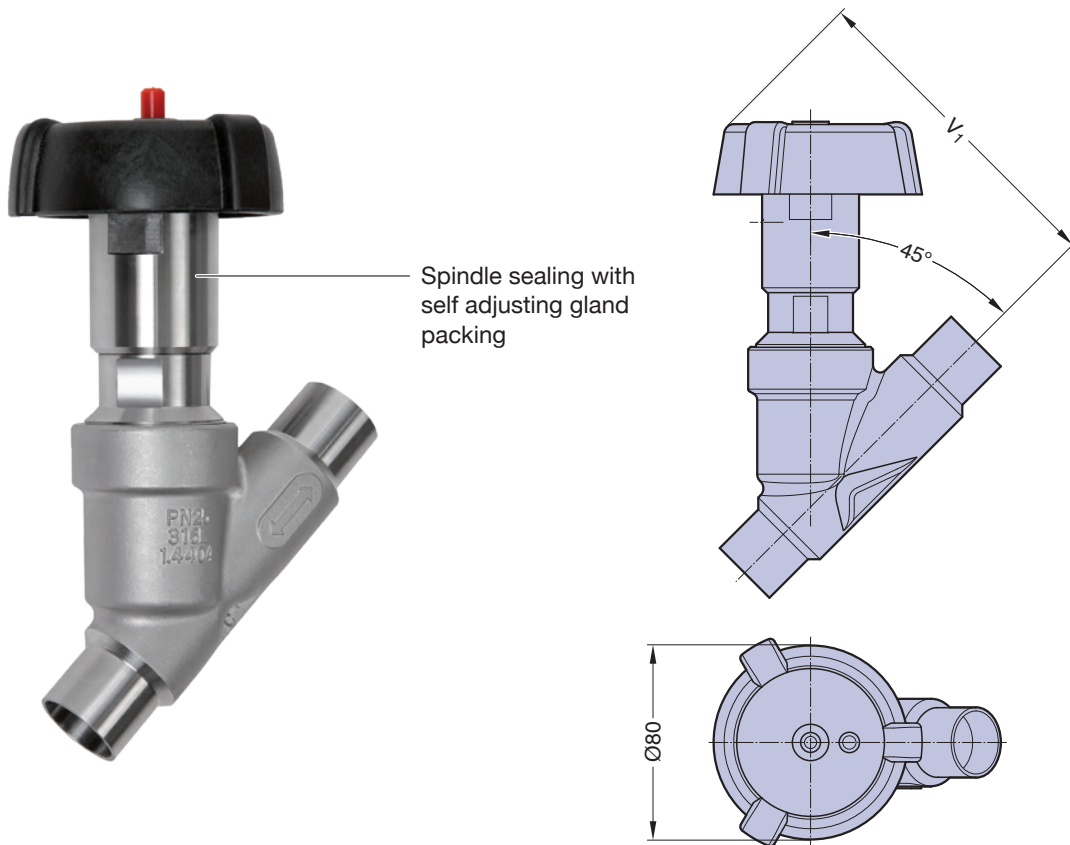

## Advantages:

- Hygienic design, easy cleaning
- High temperature resistance
- Minimized dead leg design
- Optical position indicator
- Easy maintenance
- Good regulation properties
- Clean and smooth exterior for sterile washdowns

Measurement and weight table

| DN | V <sub>1</sub> | Total weight ca. (kg) |
|----|----------------|-----------------------|
| 15 | 137            | 1,1                   |
| 20 | 135            | 1,3                   |
| 25 | 135            | 1,6                   |
| 32 | 154            | 2,3                   |
| 40 | 154            | 2,8                   |
| 50 | 154            | 4,3                   |

Valve body types see page 115 - 117

Control equipment and accessories see page 132 - 139

Working pressure, see table page 101.  
All pressures are gauge pressures.

Ordering key see page 118 and 119.

# Type 581, Manually operated

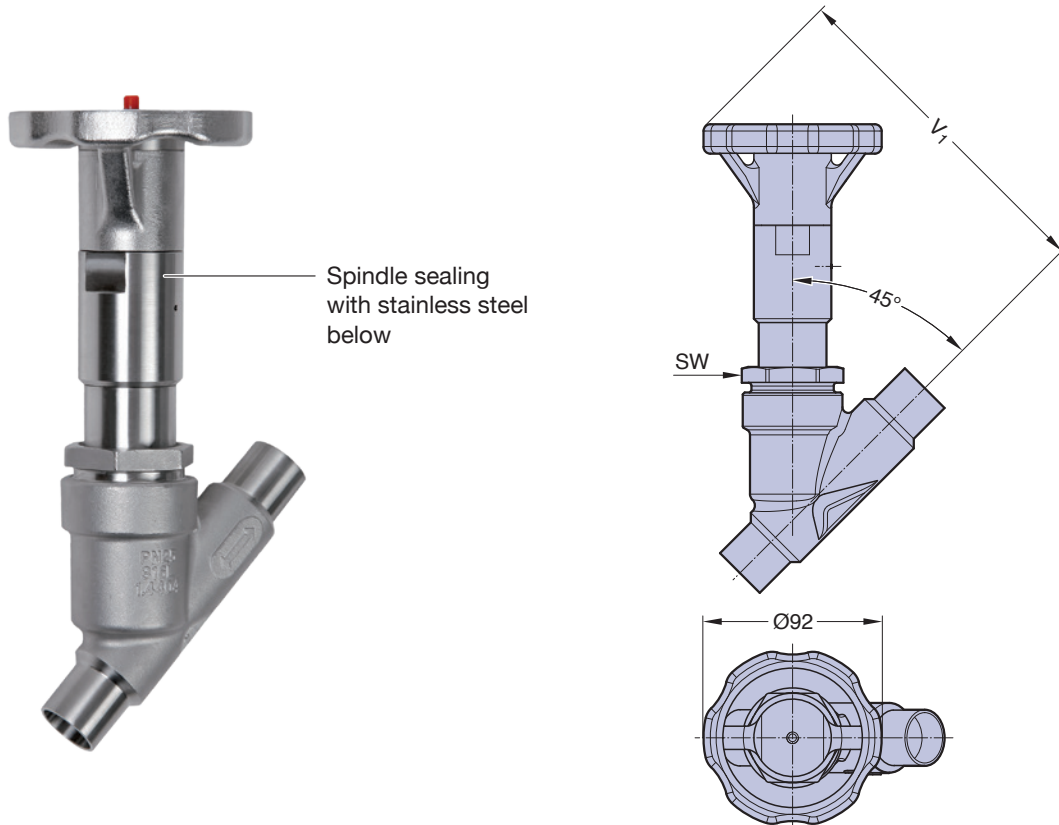

## Advantages:

- Hygienic design, easy cleaning
- High temperature resistance
- Stainless steel below
- Minimized dead leg design
- Optical position indicator
- Easy maintenance
- Good regulation properties
- Clean and smooth exterior for sterile washdowns
- Regulating cone

## Specific application:

- Pure or clean steam and gaseous media

| Measurement and weight table |    |                |                       |
|------------------------------|----|----------------|-----------------------|
| DN                           | SW | V <sub>1</sub> | Total weight ca. (kg) |
| 15                           | 36 | 177            | 1,8                   |
| 20                           | 41 | 168            | 1,9                   |
| 25                           | 46 | 175            | 2,1                   |
| 32                           | 55 | 183            | 2,9                   |
| 40                           | 60 | 189            | 3,4                   |
| 50                           | 75 | 197            | 4,4                   |

Valve body types see page 115 - 117

Control equipment and accessories see page 132 - 139

Working pressure, see table page 101.  
All pressures are gauge pressures.

Ordering key see page 118 and 119.

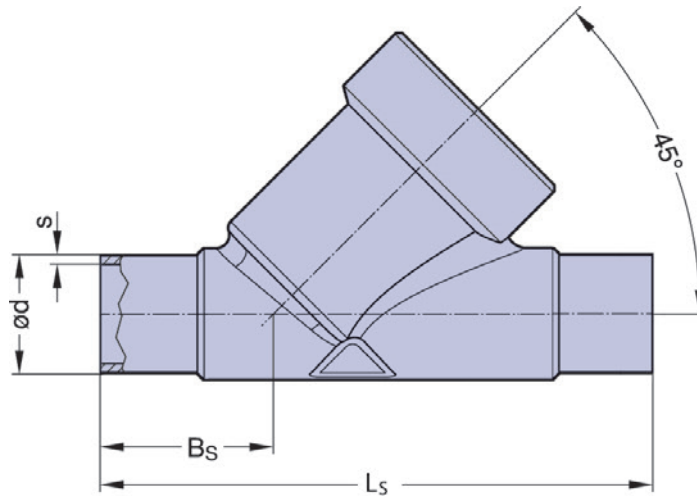

## Butt Weld End, Valve Body Material 1.4404/316L (Code 7A)

| Connection Code |     |      |                           |  |          |   |           |            |          |     |              |             |             |            |
|-----------------|-----|------|---------------------------|--|----------|---|-----------|------------|----------|-----|--------------|-------------|-------------|------------|
|                 |     |      | DIN 11850                 |  |          |   | SMS       |            | ASTM 269 |     | ISO 1127     |             |             |            |
|                 |     |      | Series 1                  |  | Series 2 |   | 3008      |            | ASME BPE |     | 40           |             |             |            |
| Code            |     |      | 41                        |  | 42       |   | 49        |            | 45       |     | 40           |             |             |            |
| DN              | LS  | BS   | Actuator Type             |  | ød       | s | ød        | s          | ød       | s   | ød           | s           | ød          | s          |
| 8               | 77  | 26   | 43, 44                    |  | -        | - | -         | -          | -        | -   | -            | -           | 13,5        | 1,6        |
| 10              | 77  | 26   | 43, 44                    |  | 12       | 1 | 13        | 1,5        | -        | -   | -            | -           | -           | -          |
| 15              | 77  | 26   | 43, 44                    |  | -        | - | -         | -          | -        | -   | 12,7         | 1,65        | -           | -          |
| 15              | 105 | 35,5 | 45, 46, 70, 71, S, T      |  | 18       | 1 | <b>19</b> | <b>1,5</b> | -        | -   | -            | -           | <b>21,3</b> | <b>1,6</b> |
| 20              | 125 | 39   | 45, 46, 70, 71, 125, S, T |  | 22       | 1 | <b>23</b> | <b>1,5</b> | -        | -   | <b>19,05</b> | <b>1,65</b> | <b>26,9</b> | <b>1,6</b> |
| 25              | 135 | 38,5 | 45, 46, 70, 71, 125, S, T |  | 28       | 1 | <b>29</b> | <b>1,5</b> | 25       | 1,2 | <b>25,4</b>  | <b>1,65</b> | <b>33,7</b> | <b>2</b>   |
| 32              | 155 | 48   | 70, 71, 125, S, T         |  | 34       | 1 | <b>35</b> | <b>1,5</b> | -        | -   | -            | -           | <b>42,4</b> | <b>2</b>   |
| 40              | 175 | 47   | 70, 71, 125, S, T         |  | 40       | 1 | <b>41</b> | <b>1,5</b> | 38       | 1,2 | <b>38,1</b>  | <b>1,65</b> | <b>48,3</b> | <b>2</b>   |
| 50              | 205 | 48   | 70, 71, 125, S, T         |  | 52       | 1 | <b>53</b> | <b>1,5</b> | 51       | 1,2 | <b>50,8</b>  | <b>1,65</b> | <b>60,3</b> | <b>2</b>   |
| 65              | 285 | 96   | 125                       |  | -        | - | <b>70</b> | <b>2</b>   | 63,5     | 1,6 | <b>63,5</b>  | <b>1,65</b> | <b>76,1</b> | <b>2</b>   |
| 80              | 285 | 96   | 125                       |  | -        | - | -         | -          | 76,1     | 1,6 | <b>76,2</b>  | <b>1,65</b> | <b>88,9</b> | <b>2,3</b> |

Measurements in mm, preferential standards in bold

# Valve Body Clamp Socket and Flange

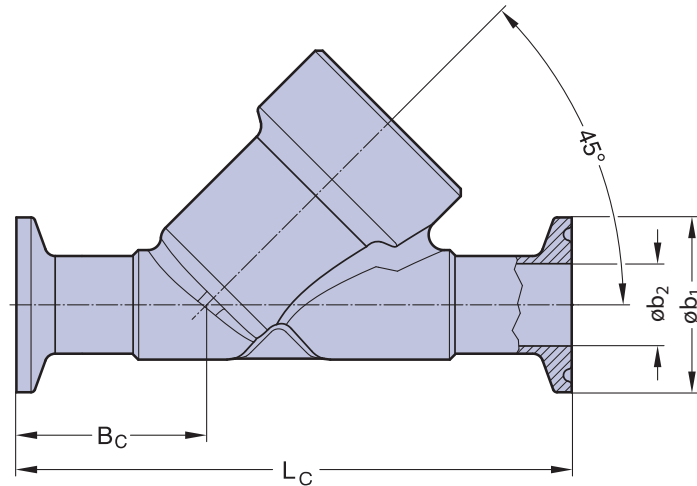

Clamp End, Valve Body Material 1.4404/316L (Code 7A for 740, 741, 742, 745)

|                  |       |                 |      |                           | Connection Code              |                        |      |                      |      |       |
|------------------|-------|-----------------|------|---------------------------|------------------------------|------------------------|------|----------------------|------|-------|
| Clamp End ident. |       | Tube End ident. |      |                           | Similar ISO 2852<br>ISO 1127 | DIN 32676<br>DIN 11850 |      | ASME BPE<br>ASME BPE |      |       |
|                  |       |                 |      |                           | 740                          | 741 / 742              |      | 745                  |      |       |
| DN               | NPS   | LC              | BC   | Actuator Type             | øb1                          | øb2                    | øb1  | øb2                  | øb1  | øb2   |
| 8                | 1/4   | 102             | 39   | 43, 44                    | 25                           | 10,3                   | -    | -                    | -    | -     |
| 10               | 3/8   | 102             | 39   | 43, 44                    | -                            | -                      | 34   | 10                   | -    | -     |
| 15               | 1/2   | 102             | 39   | 43, 44                    | -                            | -                      | -    | -                    | 25   | 9,4   |
| 15               | 1/2   | 130             | 48   | 45, 46, 70, 71, S, T      | 50,5                         | 18,1                   | 34   | 16                   | -    | -     |
| 20               | 3/4   | 150             | 54   | 45, 46, 70, 71, 125, S, T | 50,5                         | 23,7                   | 34   | 20                   | 25   | 15,75 |
| 25               | 1     | 160             | 56   | 45, 46, 70, 71, 125, S, T | 50,5                         | 29,7                   | 50,5 | 26                   | 50,5 | 22,1  |
| 32               | 1 1/4 | 180             | 60,5 | 70, 71, 125, S, T         | 64                           | 38,4                   | 50,5 | 32                   | -    | -     |
| 40               | 1 1/2 | 200             | 67   | 70, 71, 125, S, T         | 64                           | 44,3                   | 50,5 | 38                   | 50,5 | 34,8  |
| 50               | 2     | 230             | 73   | 70, 71, 125, S, T         | 77,5                         | 56,3                   | 64   | 50                   | 64   | 47,5  |
| 65               | 2 1/2 | 290             | -    | 125                       | 91                           | 72,1                   | 91   | 66                   | 77,5 | 60,2  |
| 80               | 3     | 310             | -    | 125                       | 130                          | 109,7                  | -    | -                    | 91   | 72,9  |

Measurements in mm, NPS inch

Clamp End, Valve Body Material 1.4435/316L (Code 7 for 545)

|                  |       |                 |      |                           | Connection Code      |       |
|------------------|-------|-----------------|------|---------------------------|----------------------|-------|
| Clamp End ident. |       | Tube End ident. |      |                           | ASME BPE<br>ASME BPE |       |
|                  |       |                 |      |                           | 545                  |       |
| DN               | NPS   | LC              | BC   | Actuator Type             | øb1                  | øb2   |
| 15               | 1/2   | 101,6           | 28,5 | 45, 46, 70, 71, S, T      | 25                   | 9,4   |
| 20               | 3/4   | 101,6           | 35   | 45, 46, 70, 71, 125, S, T | 25                   | 15,75 |
| 25               | 1     | 114,3           | 33   | 45, 46, 70, 71, 125, S, T | 50,5                 | 22,1  |
| 40               | 1 1/2 | 139,7           | 40   | 70, 71, 125, S, T         | 50,5                 | 34,8  |
| 50               | 2     | 158,8           | 44   | 70, 71, 125, S, T         | 64                   | 47,5  |

Measurements in mm, NPS inch

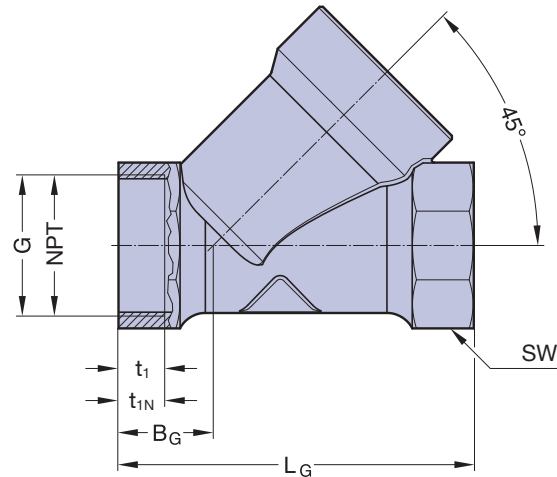

**Threaded Socket, Connection Code 1 (DIN ISO 228) & 1N (NPT), Valve Body Material 1.4408 (Code 7B)**

| DN | L <sub>G</sub> | B <sub>G</sub> | Actuator Type             | DIN ISO 228, Code 1 |                | NPT, Code 1N |                 | SW |      |
|----|----------------|----------------|---------------------------|---------------------|----------------|--------------|-----------------|----|------|
|    |                |                |                           | G                   | t <sub>1</sub> | NPT          | t <sub>1N</sub> |    |      |
| 15 | 65             | 17             | 45, 46, 70, 71, S, T      | G 1/2               | 15,0           | NPT 1/2      | 16              | 27 | 6-kt |
| 20 | 75             | 18             | 45, 46, 70, 71, 125, S, T | G 3/4               | 14,0           | NPT 3/4      | 17              | 32 | 6-kt |
| 25 | 90             | 24             | 45, 46, 70, 71, 125, S, T | G 1                 | 15,0           | NPT 1        | 17              | 39 | 6-kt |
| 32 | 110            | 33             | 70, 71, 125, S, T         | G 1 1/4             | 17,0           | n.a.         | n.a.            | 50 | 8-kt |
| 40 | 120            | 30             | 70, 71, 125, S, T         | G 1 1/2             | 17,0           | NPT 1 1/2    | 21              | 55 | 8-kt |
| 50 | 150            | 40             | 70, 71, 125, S, T         | G 2                 | 18,5           | NPT 2        | 22              | 70 | 8-kt |
| 65 | 190            | 46             | 125                       | G 2 1/2             | 26,0           | NPT 2 1/2    | 30              | 85 | 8-kt |

Measurements in mm, G-Thread

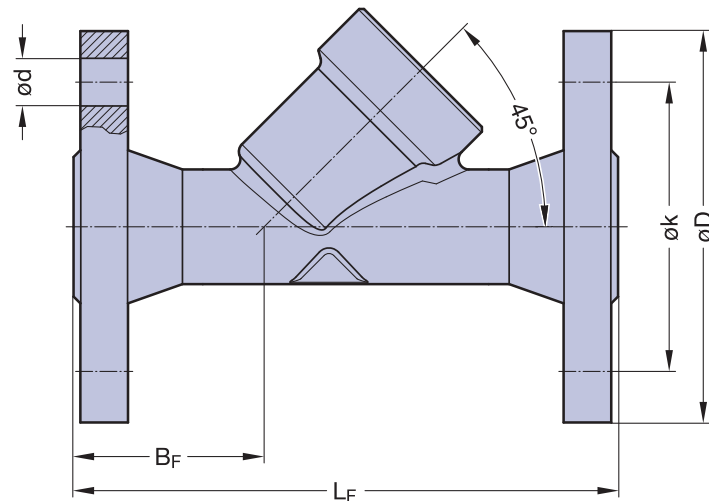

**Flange, Connection Code 51, Valve Body Material 1.4404/316L (Code 7A)**

| DN | L <sub>F</sub> | B <sub>F</sub> | Actuator Type             | øD  | ød | øk  | number of drilling |
|----|----------------|----------------|---------------------------|-----|----|-----|--------------------|
| 15 | 130            | 42             | 45, 46, 70, 71, S, T      | 95  | 14 | 65  | 4                  |
| 20 | 150            | 54             | 45, 46, 70, 71, 125, S, T | 105 | 14 | 75  | 4                  |
| 25 | 160            | 56             | 45, 46, 70, 71, 125, S, T | 115 | 18 | 85  | 4                  |
| 32 | 180            | 59             | 70, 71, 125, S, T         | 140 | 18 | 100 | 4                  |
| 40 | 200            | 71             | 70, 71, 125, S, T         | 150 | 18 | 110 | 4                  |
| 50 | 230            | 83             | 70, 71, 125, S, T         | 165 | 18 | 125 | 4                  |
| 65 | 290            | -              | 125                       | 185 | 18 | 145 | 4                  |
| 80 | 310            | -              | 125                       | 200 | 18 | 160 | 8                  |

Measurements in mm



# Ordering Key and Ordering Example

| Pos. | Description   | Code      | Specification  |
|------|---|-----------|--|
| 1    | Type:   | 580       | Manual valve, plastic hand wheel   |
|      |   | 581       | Manual valve, stainless steel hand wheel, metal bellow                                     |
|      |   | 582       | Pneumatic valve, plastic actuator material PAMX D6, metal bellow                           |
|      |   | 584       | Pneumatic valve, plastic actuator material PAMX D6   |
|      |   | 590       | Pneumatic valve, two stage plastic actuator (only Cf. 1)                                   |
| 2    | Size:   | 08-80     | DN 8, 10, 15, 20, 25, 32, 40, 50, 65, 80   |
| 3    | Valve body material:  | 7         | 1.4435/F316L ASME BPE st. steel investment cast (S = 0,005 – 0,017)                        |
|      |   | 7A        | 1.4404/316L/31603 st. steel investment cast (S ≤ 0,030)                                    |
|      |   | 7B        | Stainless steel, investment cast 1.4408  |
| 4    | Valve body end connection:  | <b>1</b>  | <b>Threaded socket BSP</b>   |
|      |   | 1N        | Threaded socket NPT  |
|      |   | <b>40</b> | <b>Butt weld end ISO 1127 (DIN 11866 Series B)</b>   |
|      |   | 41        | Butt weld end DIN 11850 Series 1   |
|      |   | <b>42</b> | <b>Butt weld end DIN 11850 Series 2 (DIN 11866 Series A)</b>                               |
|      |   | <b>45</b> | <b>Butt weld end ASTM 269 ASME BPE (DIN 11866 Series C)</b>                                |
|      |   | 49        | Butt weld end SMS 3008   |
|      |   | 51        | Flange PN10/16 DIN 2564, face to face DIN EN 558-1, Series 1                               |
|      |   | 740       | Clamp ISO 1127, for tube EN ISO 1127 face to face DIN EN 558-1, Series 1                   |
|      |   | 742       | Clamp DIN 32676, for tube DIN 11850 face to face DIN EN 558-1, Series 1                    |
| 745  | Clamp ASME BPE, for tube ASME BPE face to face DIN EN 558-1, Series 1 |           |  |
| 5    | Sealing:  | 3         | Encapsulated circumferential PTFE sealing  |
| 6.1  | Actuator control function:  | 1         | Manually operated  |
|      |   | 2         | Normally closed (NC), orientation 90° to flow direction                                    |
|      |   | 3         | Normally open (NO), orientation 90° to flow direction                                      |
| 6.2  | Actuator type:  | S         | Plastic hand wheel   |
|      |   | T         | Stainless steel hand wheel   |
|      |   | 43        | Plastic actuator with Stainless steel adaption, piston Ø 45<br>Flow <b>below</b> the seat  |
|      |   | 44        | Plastic actuator with Stainless steel adaption, piston Ø 45<br>Flow <b>above</b> the seat  |
|      |   | 45        | Plastic actuator with Stainless steel adaption, piston Ø 45<br>Flow <b>below</b> the seat  |
|      |   | 46        | Plastic actuator with Stainless steel adaption, piston Ø 45<br>Flow <b>above</b> the seat  |
|      |   | 70        | Plastic actuator with Stainless steel adaption, piston Ø 70<br>Flow <b>below</b> the seat  |
|      |   | 71        | Plastic actuator with Stainless steel adaption, piston Ø 70<br>Flow <b>above</b> the seat  |
|      |   | 125       | Plastic actuator with Stainless steel adaption, piston Ø 125<br>Flow <b>below</b> the seat |
|      |   | 7         | Surface roughness of the bodies in Ra: (µm)  |
| 03   | Internal mechanically polished Ra ≤ 0,8 µm + Electropolished          |           |  |
| 07   | Internal mechanically polished Ra ≤ 0,6 µm                            |           |  |
| 08   | Internal mechanically polished Ra ≤ 0,6 µm + Electropolished          |           |  |
| 09   | Internal mechanically polished Ra ≤ 0,4 µm                            |           |  |
| 10   | Internal mechanically polished Ra ≤ 0,4 µm + Electropolished          |           |  |
| 8    | Regulating Cone:  | AL        | Linear version for valve body end connection code 42, 742                                  |
|      |   | AP        | Equal-percentage version for valve body end connection code 42, 742                        |
|      |   | BL        | Linear version for valve body end connection code 40, 740                                  |
|      |   | BP        | Equal-percentage version for valve body end connection code 40, 740                        |
|      |   | CL        | Linear version for valve body end connection code 45, 745                                  |
|      |   | CP        | Equal-percentage version for valve body end connection code 45, 745                        |
|      |   | DL        | Linear version for valve body end connection code 545                                      |
|      |   | DP        | Equal-percentage version for valve body end connection code 545                            |

Bold = preferential standards

# Type 584, Actuator 70



Code: 1 2 3 4 5 6.1 6.2

Artikel No.: 584 . 25 . 75 . 1 . 3 . 1 70

**Type:** 584  
Pneumatic valve  
Plastic actuator  
Material PAMX D6

**Size:** DN 25

**Valve Body Material:** Stainless steel, investment cast 1.4408/316

**Valve Body End Connection:** Threaded socket

**Actuator Type:** Plastic actuator with Stainless steel adaption, piston Ø 70

**Actuator Control Function:** Normally closed (NC), orientation 90° to flow direction

**Sealing:** Encapsulated circumferential PTFE Sealing

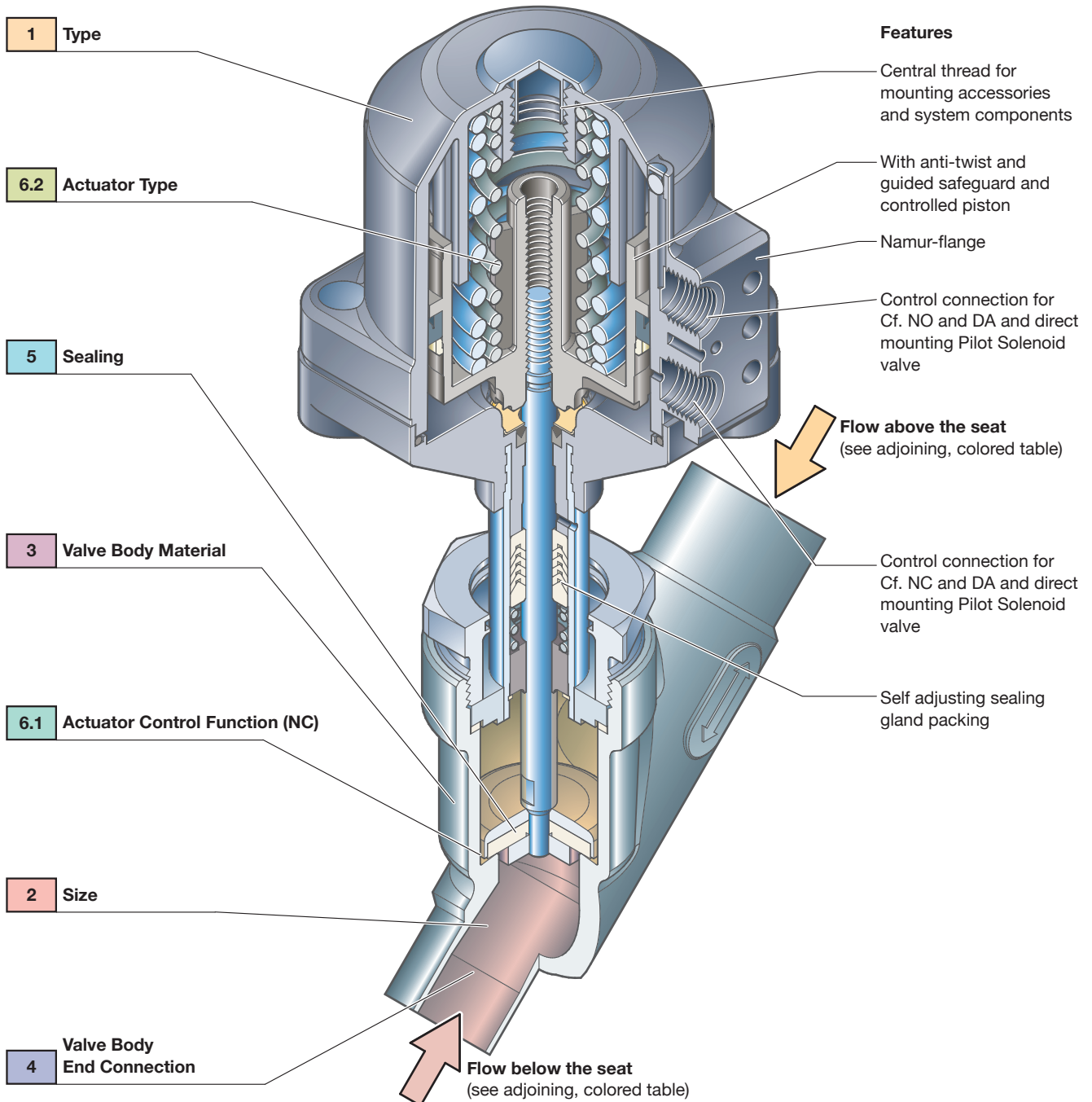





|          |   |  |
|----------|---|--|
| <b>1</b> | <b>Introduction</b><br>Overview   | Page<br>4 - 11   |
| <b>2</b> | <b>Media Contacted Components</b><br>Diaphragms<br>Valve Bodies (fold out page)<br>Butt Weld Tube Ends (fold out page)<br><b>Aseptic Connections</b>  | 14 - 19<br>20<br>21<br><b>22 - 24</b>  |
| <b>3</b> | <b>Aseptic Diaphragm Valves</b><br><b>Overview Diaphragm Aseptic Valves</b><br>Why Aseptic Diaphragm Valve?<br>Self Draining - Two-Way Valve<br>Innovative Design<br><b>Aseptic Diaphragm Valves</b><br>STERIPUR Series<br>KMA Series<br>KMD Series<br><b>Ordering Key and Ordering Example</b>   | 26, 27<br>28<br>29<br>30 - 33<br>34 - 46<br>48 - 58<br>60 - 65<br>66 - 68        |
| <b>4</b> | <b>Aseptic Diaphragm Valve Configurations</b><br><b>D-Rule</b><br><b>Welded Valve Configurations</b><br><b>Multiport Valves</b><br>Why Multiport Valves?<br>Main line open, Loop Valves (e.g. T-Valve)<br>All lines and valve ports able to close<br>The way of customized multiport valve designs<br>Specification Multiport Valves<br><b>Tank Valves</b><br><b>Process Solutions</b><br>Sterile Sampling Unit<br>Purified Steam Sampling Unit | 72<br>73 - 75<br>76<br>77 - 81<br>82 - 87<br>88<br>89<br>90 - 93<br>94<br>95     |
| <b>5</b> | <b>Angle Seat Valves</b><br>Description and Features<br>Technical Data<br>Regulating cone<br>2/2-Way Angle Seat Valves<br>Valve Body Dimensions<br>Ordering Key and Ordering Example  | 98, 99<br>100 - 101<br>102 - 105<br>106 - 114<br>115 - 117<br>118, 119           |
| <b>6</b> | <b>Ball Valves</b><br>Manual Ball Valve Description and Features<br>Pneumatically Ball Valve Description and Features<br>Technical Data<br>Ordering Key   | 123<br>124<br>125 - 128<br>129   |
| <b>7</b> | <b>System Components and Process Automation</b><br><b>Overview</b><br>Manual Adjustment - Optical Indication<br>Electrical Switch Boxes - Pilot Control<br><b>Detailed Information</b><br>3/2 Way Plastic Pilot Valve<br>Control Head Switch 024.63. - 024.89.<br>Contact-Free Limit Switch 024.50<br><b>Process Automation, Electropneumatic Positioners</b><br><b>Overview Product Range</b><br><b>Glossary</b>                               | 132<br>133<br>134<br>135, 136<br>137<br>138, 139<br>140 - 143<br>144<br>145, 146 |



## Manual Valve DN 8 – 100 (1/4" – 4")

The Steriflu 942 is a manually operated ball valve with a stainless steel handle with a plastic sleeve.



### Features

- End connection extended butt weld ends or clamp ends
- V-ring stem seals
- EN ISO 5211 mount plate ensures direct assembly of actuators
- Manual handle with locking device
- Standard seat material FDA compliant 21CFR177.1550
- Butt weld ends with controlled delta ferrit content
- Suitable for CIP and SIP cleaning processes
- Antistatic device

| Working pressure |            |
|------------------|------------|
| DN               | PS (bar) * |
| 8                | 63         |
| 10               | 63         |
| 15               | 63         |
| 20               | 63         |
| 25               | 40         |
| 32               | 31         |
| 40               | 25         |
| 50               | 20         |
| 65               | 15         |
| 80               | 12         |
| 100              | 10         |

\* Fluid group 2 only

### Technical Data

|                           |   |
|---------------------------|---|
| Control function:         | Manually operated   |
| Max. working pressure:    | See table   |
| Max. working temperature: | 180°C (356°F) dependent on application  |
| Sealing material:         | PTFE full cavity or non-cavity filler   |
| Ball valve material:      | Body/Ball/Cap CF3M (316L)   |
| End connection:           | Butt weld ends DIN 11850<br>Butt weld ends ASME BPE<br>Butt weld ends ISO 1127<br>Clamp ends ASME BPE<br>see page 126 and 127 |
| Surface finish:           | Internal 0,6µm polished, electropolished<br>external  |
| Flow rate:                | Kv in m <sup>3</sup> /h see page 125  |

## Pneumatically Operated Valve DN 8 – 100 (1/4" – 4")



The Steriflu 342 is pneumatically operated with a piston actuator alternatively single or double acting. The pneumatic actuator has an extruded aluminium housing with internal and external Alodur special hard anodization for corrosion protection.

### Features

- End connection extended butt weld ends or clamp ends
- V-ring stem seals
- EN ISO 5211 mount plate ensures direct assembly of actuators
- Pneumatically operated actuator with optical indication as standard
- Standard seat material FDA compliant 21CFR177.1550
- Butt weld ends with controlled delta ferrit content
- Suitable for CIP and SIP cleaning processes
- Antistatic device

### Optional

- Stroke limiter

| Working pressure |            |
|------------------|------------|
| DN               | PS (bar) * |
| 8                | 63         |
| 10               | 63         |
| 15               | 63         |
| 20               | 63         |
| 25               | 40         |
| 32               | 31         |
| 40               | 25         |
| 50               | 20         |
| 65               | 15         |
| 80               | 12         |
| 100              | 10         |

\* Fluid group 2 only

### Technical Data

|                           |   |
|---------------------------|---|
| Control function:         | Pneumatically operated<br>Fail safe close (NC): Cf. 1<br>Double acting (DA): Cf. 3  |
| Direction                 |   |
| Control connection:       | At Cf. 1 & 3, 90° to flow direction   |
| Max. working pressure:    | See table<br>Higher working pressure may be achieved with different actuator. Please consult a SED factory representative for working pressure above the indicated maximum. |
| Max. working temperature: | 80°C (176°F) dependent on application<br>Version > 100°C (>212°F) on request  |
| Control pressure:         | 6 – 8 bar (87- 115 psi)   |
| Sealing material:         | PTFE full cavity or non-cavity filler   |
| Ball valve material:      | Body/Ball/Cap CF3M (316L)   |
| End connection:           | Butt weld ends DIN 11850<br>Butt weld ends ASME BPE<br>Butt weld ends ISO 1127<br>Clamp ends ASME BPE<br>see page 126 to127   |
| Surface finish:           | Internal 0,6µm polished, electropolished<br>external  |
| Flow rate:                | Kv in m <sup>3</sup> /h see page 125  |

| All versions |        |        | ASME BPE    |    | DIN 11851-2 |    | EN ISO 1127 |    |
|--------------|--------|--------|-------------|----|-------------|----|-------------|----|
| DN           | NPS    | Weight | EN ISO-5211 |    | EN ISO-5211 |    | EN ISO-5211 |    |
| DIN          | INCH   | Kg     | F           | SW | F           | SW | F           | SW |
| 8            | 1/4"   | 0,6    | -           | -  | -           | -  | F03-F04     | 9  |
| 10           | 3/8"   | 0,6    | -           | -  | F03-F04     | 9  | F03-F04     | 9  |
| 15           | 1/2"   | 0,7    | F03-F04     | 9  | F03-F04     | 9  | F04-F05     | 11 |
| 20           | 3/4"   | 0,9    | F04-F05     | 9  | F04-F05     | 11 | F04-F05     | 11 |
| 25           | 1"     | 1,2    | F05-F07     | 11 | F04-F05     | 11 | F05-F07     | 14 |
| 32           | 1 1/4" | 1,8    | -           | -  | F05-F07     | 14 | F05-F07     | 14 |
| 40           | 1 1/2" | 2,9    | F05-F07     | 14 | F05-F07     | 14 | F05-F07     | 14 |
| 50           | 2"     | 4,3    | F07-F10     | 14 | F05-F07     | 14 | F07-F10     | 17 |
| 65           | 2 1/2" | 8,6    | F07-F10     | 17 | F07-F10     | 17 | F07-F10     | 17 |
| 80           | 3"     | 12,4   | F07-F10     | 17 | F07-F10     | 17 | F07-F10     | 17 |
| 100          | 4"     | 21,0   | F10-F12     | 22 | F10-F12     | 22 | F10-F12     | 22 |

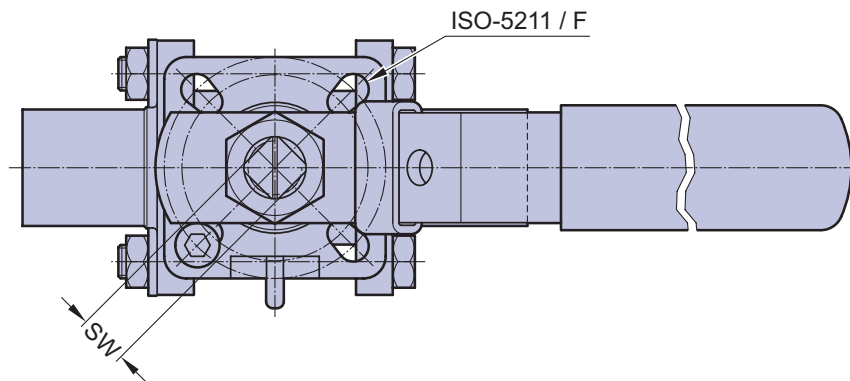

| DN  | NPS    | Torque* | Kv-Value (m3/h)                            |                             |
|-----|--------|---------|--|-----------------------------|
| DIN | INCH   | (Nm)    | Butt weld ends /<br>Clamp ends<br>ASME BPE | Butt weld ends<br>DIN / ISO |
| 8   | 1/4"   | 9       | -  | 7,0                         |
| 10  | 3/8"   | 9       | -  | 7,0                         |
| 15  | 1/2"   | 10      | 9,0  | 13,0                        |
| 20  | 3/4"   | 11      | 26,0                                       | 34,0                        |
| 25  | 1"     | 16      | 55,0                                       | 60,0                        |
| 32  | 1-1/4" | 25      | -  | 94,0                        |
| 40  | 1-1/2" | 27      | 170,0                                      | 213,0                       |
| 50  | 2"     | 54      | 349,0                                      | 366,0                       |
| 65  | 2-1/2" | 73      | 510,0                                      | 595,0                       |
| 80  | 3"     | 130     | 893,0                                      | 935,0                       |
| 100 | 4"     | 158     | 1654,0                                     | 1700,0                      |

\* incl. 30% safety margin

| DN  | NPS    | Butt weld ends DIN 11850 series 2 (Code 42) |       |     |     |      |       |       |
|-----|--------|---|-------|-----|-----|------|-------|-------|
| DIN | INCH   | L1  | Bs    | Ød  | S   | ØA   | W     | H     |
| 8   | 1/4"   | -   | -     | -   | -   | -    | -     | -     |
| 10  | 3/8"   | 135   | 55,75 | 13  | 1,5 | 9,4  | 130,7 | 66,8  |
| 15  | 1/2"   | 135   | 53,50 | 19  | 1,5 | 14   | 130,7 | 75,6  |
| 20  | 3/4"   | 165   | 65,50 | 23  | 1,5 | 18,1 | 165,6 | 84,6  |
| 25  | 1"     | 165   | 65,50 | 29  | 1,5 | 22,1 | 165,6 | 84,6  |
| 32  | 1 1/4" | 165   | 56,00 | 35  | 1,5 | 29,7 | 187   | 117   |
| 40  | 1 1/2" | 165   | 56,00 | 41  | 1,5 | 34,8 | 187   | 117   |
| 50  | 2"     | 190   | 62,75 | 53  | 1,5 | 47,5 | 187   | 124,5 |
| 65  | 2 1/2" | 205   | 60,00 | 70  | 2,0 | 60,2 | 265   | 162,2 |
| 80  | 3"     | 265   | 82,25 | 85  | 2,0 | 72,9 | 265   | 169,2 |
| 100 | 4"     | 306   | 92,25 | 104 | 2,0 | 97,4 | 393   | 189,5 |

| DN  | NPS    | Butt weld ends ISO 1127 (Code 40) |       |       |     |      |       |       |
|-----|--------|-----------------------------------|-------|-------|-----|------|-------|-------|
| DIN | INCH   | L                                 | Bs    | Ød    | S   | ØA   | W     | H     |
| 8   | 1/4"   | 135                               | 55,75 | 13,5  | 1,6 | 9,4  | 130,7 | 66,8  |
| 10  | 3/8"   | 135                               | 53,50 | 17,2  | 1,6 | 14   | 130,7 | 75,6  |
| 15  | 1/2"   | 165                               | 65,50 | 21,3  | 1,6 | 18,1 | 165,6 | 84,6  |
| 20  | 3/4"   | 165                               | 65,50 | 26,9  | 1,6 | 22,1 | 165,6 | 84,6  |
| 25  | 1"     | 165                               | 56,00 | 33,7  | 2,0 | 29,7 | 187   | 117   |
| 32  | 1 1/4" | 165                               | 56,00 | 42,4  | 2,0 | 34,8 | 187   | 117   |
| 40  | 1 1/2" | 190                               | 62,75 | 48,3  | 2,0 | 44,3 | 187   | 124,5 |
| 50  | 2"     | 205                               | 60,00 | 60,3  | 2,0 | 56,3 | 265   | 162,2 |
| 65  | 2 1/2" | 265                               | 82,25 | 76,1  | 2,0 | 72,9 | 265   | 169,2 |
| 80  | 3"     | 265                               | 82,25 | 88,9  | 2,3 | 72,9 | 393   | 189,5 |
| 100 | 4"     | 306                               | 92,25 | 114,3 | 2,3 | 97,4 | 393   | 189,5 |

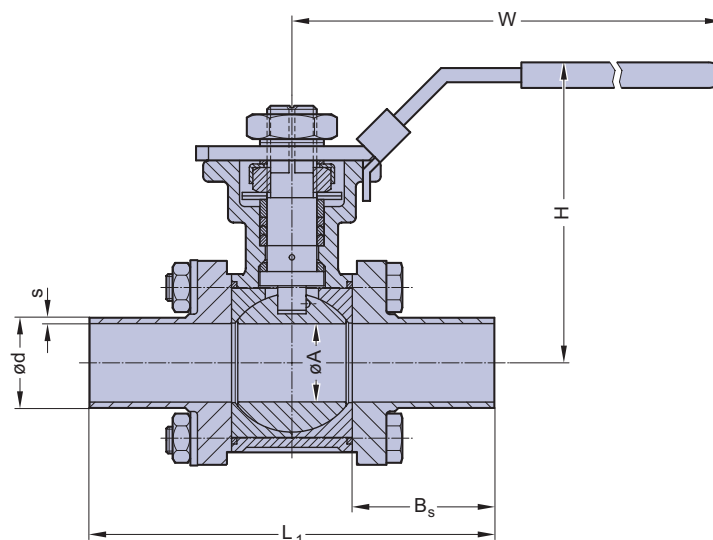

| DN  | NPS    | Butt weld ends ASME BPE (Code 45) |       |       |      |       |       |       |
|-----|--------|-----------------------------------|-------|-------|------|-------|-------|-------|
| DIN | INCH   | L1                                | Bs    | Ød    | S    | ØA    | W     | H     |
| 15  | 1/2"   | 135                               | 55,75 | 12,7  | 1,65 | 9,4   | 130,7 | 66,8  |
| 20  | 3/4"   | 135                               | 53,5  | 19,05 | 1,65 | 15,75 | 130,7 | 75,6  |
| 25  | 1"     | 165                               | 65,5  | 25,4  | 1,65 | 22,1  | 165,6 | 84,6  |
| 40  | 1 1/2" | 165                               | 56    | 38,1  | 1,65 | 34,8  | 187   | 117   |
| 50  | 2"     | 190                               | 62,75 | 50,8  | 1,65 | 47,5  | 187   | 124,5 |
| 65  | 2 1/2" | 205                               | 60    | 63,5  | 1,65 | 60,2  | 265   | 162,2 |
| 80  | 3"     | 265                               | 80,25 | 76,2  | 1,65 | 72,9  | 265   | 169,2 |
| 100 | 4"     | 306                               | 92,25 | 101,6 | 2,10 | 97,4  | 393   | 189,5 |

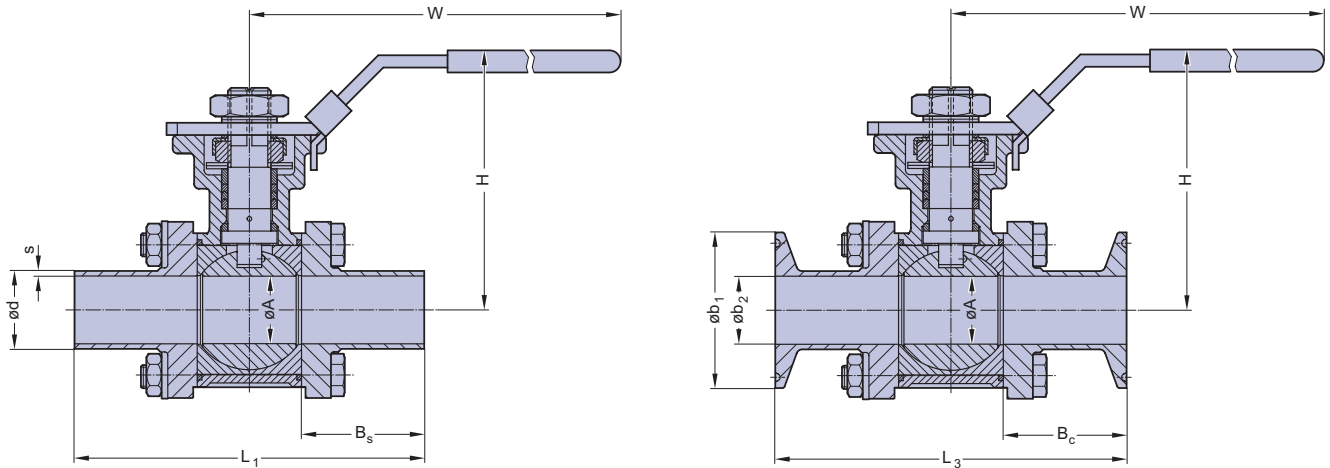

| DN  | NPS    | Clamp ends ASME BPE (Code 545 / 745) |      |        |       |       |       |       |
|-----|--------|--------------------------------------|------|--------|-------|-------|-------|-------|
| DIN | INCH   | L3                                   | Bc   | b1     | b2    | ØA    | W     | H     |
| 15  | 1/2"   | 89,0                                 | 32,8 | 25     | 9,4   | 9,4   | 130,7 | 66,8  |
| 20  | 3/4"   | 101,0                                | 36,5 | 25     | 15,75 | 15,75 | 130,7 | 75,6  |
| 25  | 1"     | 114,0                                | 40,0 | 50,39  | 22,1  | 22,1  | 165,6 | 84,6  |
| 40  | 1 1/2" | 140,0                                | 43,5 | 50,39  | 34,8  | 34,8  | 187   | 117   |
| 50  | 2"     | 153,3                                | 46,4 | 63,91  | 47,5  | 47,5  | 187   | 124,5 |
| 65  | 2 1/2" | 197,0                                | 56,0 | 77,39  | 60,2  | 60,2  | 265   | 162,2 |
| 80  | 3"     | 229,5                                | 64,5 | 90,91  | 72,9  | 72,9  | 265   | 169,2 |
| 100 | 4"     | 243,5                                | 61,0 | 118,92 | 97,4  | 97,4  | 393   | 189,5 |

| Actuator type  | 0015  | 0030    | 0060    | 0100    | 0150    | 0220    | 0300    | 0450    |
|----------------|-------|---------|---------|---------|---------|---------|---------|---------|
| ISO Flange     | F04   | F05/F07 | F05/F07 | F05/F07 | F07/F10 | F07/F10 | F07/F10 | F10/F12 |
| Air connection | G 1/8 | G 1/8   | G 1/8   | G 1/8   | G 1/4   | G 1/4   | G 1/4   | G 1/4   |
| A              | 136,0 | 153,5   | 203,5   | 241,0   | 259,0   | 304,0   | 333,0   | 394,5   |
| B              | 69,0  | 85,0    | 102,0   | 115,0   | 127,0   | 145,0   | 157,0   | 177,0   |
| H              | 20    | 20      | 20      | 20      | 20      | 30      | 30      | 30      |
| M              | 29,0  | 36,0    | 42,5    | 49,5    | 55,5    | 64,0    | 69,5    | 80,0    |
| N              | 43,0  | 48,5    | 50,5    | 56,5    | 63,0    | 72,0    | 77,0    | 86,0    |
| O              | 11    | 14      | 14      | 17      | 17      | 22      | 22      | 27      |
| Weight (kg)    |       |         |         |         |         |         |         |         |
| DA             | 1,0   | 1,6     | 2,7     | 3,8     | 5,2     | 8,1     | 10,0    | 14,2    |
| NC, NO         | 1,1   | 1,9     | 3,1     | 4,4     | 6,0     | 9,4     | 12,4    | 17,1    |

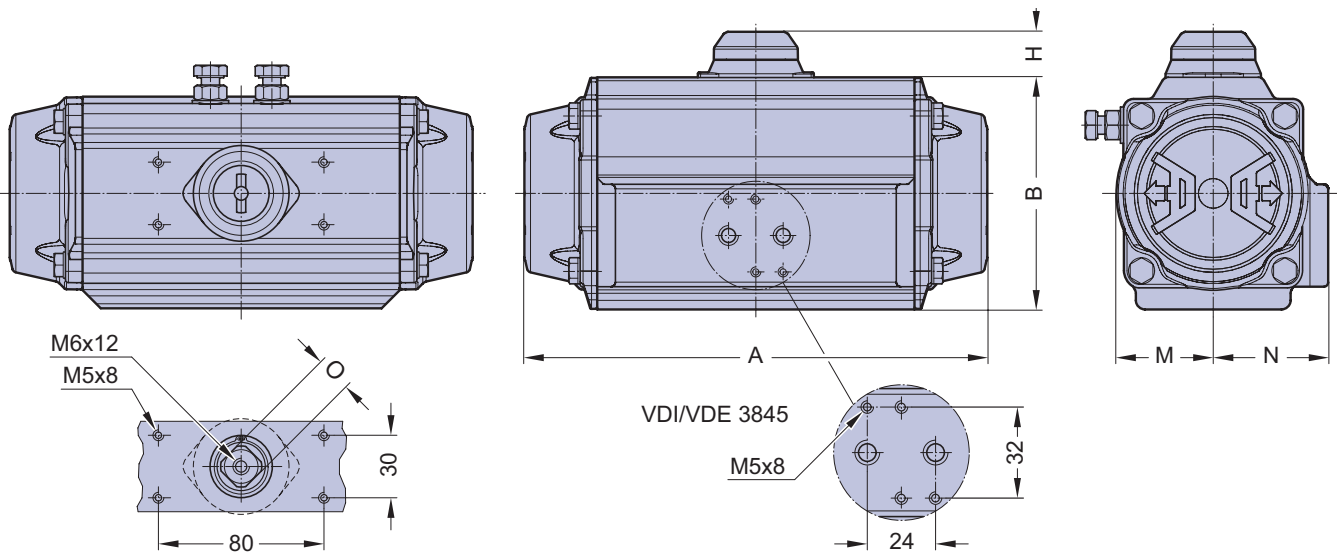



# Ordering Key



| 1    | 2    | 3                   | 4                     | 5                | 6.1                       | 6.2           | 7                                     |
|------|------|---------------------|-----------------------|------------------|---------------------------|---------------|---------------------------------------|
| Type | Size | Ball valve material | Ball valve connection | Sealing material | Actuator control function | Actuator type | Surface roughness of the bodies in Ra |

| Pos. | Description                                 | Code   | Specification   |
|------|---|--|---|
| 1    | Type:                                       | 342<br>942   | Aluminium actuator, pneumatic<br>Stainless steel actuator, manual   |
| 2    | Size:                                       | 15 - 100   | DN 15, 20, 25, 32, 40, 50, 65, 80, 100  |
| 3    | Ball valve material:                        | 7A   | Body/Ball/Cap 1.4404/316L, CF3M Investment cast   |
| 4    | Ball valve connection:                      | 40<br>42<br>45<br>545<br>745   | Butt weld end acc. EN ISO 1127 (DIN 11866 Series B)<br>Butt weld end acc. DIN 11850 Series 2 (DIN 11866 Series A)<br>Butt weld end acc. ASME BPE MFS length (DIN 11866 Series C)<br>Clamp ASME BPE, for tube ASME BPE, face to face ASME BPE Table DT-4.4.1-1<br>Clamp ASME BPE, for tube ASME BPE, face to face, MFS length  |
| 5    | Sealing material:                           | 3F<br>3S   | PTFE, FDA compliant, full cavity sealing<br>PTFE, FDA compliant, standard sealing   |
| 6.1  | Actuator control function:                  | -<br>1<br>2<br>3   | Manually operated<br>Normally closed (NC)<br>Normally open (NO)<br>Double-acting (DA)   |
| 6.2  | Actuator type:                              | T<br>D0015<br>D0030<br>D0060<br>D0100<br>D0150<br>D0220<br>S0015<br>S0030<br>S0060<br>S0150<br>S0220<br>S0300<br>S0450 | Stainless steel, hand lever<br>Aluminum actuator, double acting, Actuator size 0015<br>Aluminum actuator, double acting, Actuator size 0030<br>Aluminum actuator, double acting, Actuator size 0060<br>Aluminum actuator, double acting, Actuator size 0100<br>Aluminum actuator, double acting, Actuator size 0150<br>Aluminum actuator, double acting, Actuator size 0220<br>Aluminum actuator, single acting, Actuator size 0015<br>Aluminum actuator, single acting, Actuator size 0030<br>Aluminum actuator, single acting, Actuator size 0060<br>Aluminum actuator, single acting, Actuator size 0150<br>Aluminum actuator, single acting, Actuator size 0220<br>Aluminum actuator, single acting, Actuator size 0300<br>Aluminum actuator, single acting, Actuator size 0450 |
| 7    | Surface roughness of the bodies in Ra (µm): | 08<br>SF1  | Internal mechanically polished Ra ≤ 0,6 µm + Electropolished<br>Mech. polished Ra ≤ 0,51 µm (20µ-inch), ASME BPE Table SF-2.4-1   |



|          |   |  |
|----------|---|--|
| <b>1</b> | <b>Introduction</b><br>Overview   | Page<br>4 - 11   |
| <b>2</b> | <b>Media Contacted Components</b><br>Diaphragms<br>Valve Bodies (fold out page)<br>Butt Weld Tube Ends (fold out page)<br><b>Aseptic Connections</b>  | 14 - 19<br>20<br>21<br><b>22 - 24</b>  |
| <b>3</b> | <b>Aseptic Diaphragm Valves</b><br><b>Overview Diaphragm Aseptic Valves</b><br>Why Aseptic Diaphragm Valve?<br>Self Draining - Two-Way Valve<br>Innovative Design<br><b>Aseptic Diaphragm Valves</b><br>STERIPUR Series<br>KMA Series<br>KMD Series<br><b>Ordering Key and Ordering Example</b>   | 26, 27<br>28<br>29<br>30 - 33<br>34 - 46<br>48 - 58<br>60 - 65<br>66 - 68        |
| <b>4</b> | <b>Aseptic Diaphragm Valve Configurations</b><br><b>D-Rule</b><br><b>Welded Valve Configurations</b><br><b>Multiport Valves</b><br>Why Multiport Valves?<br>Main line open, Loop Valves (e.g. T-Valve)<br>All lines and valve ports able to close<br>The way of customized multiport valve designs<br>Specification Multiport Valves<br><b>Tank Valves</b><br><b>Process Solutions</b><br>Sterile Sampling Unit<br>Purified Steam Sampling Unit | 72<br>73 - 75<br>76<br>77 - 81<br>82 - 87<br>88<br>89<br>90 - 93<br>94<br>95     |
| <b>5</b> | <b>Angle Seat Valves</b><br>Description and Features<br>Technical Data<br>Regulating cone<br>2/2-Way Angle Seat Valves<br>Valve Body Dimensions<br>Ordering Key and Ordering Example  | 98, 99<br>100 - 101<br>102 - 105<br>106 - 114<br>115 - 117<br>118, 119           |
| <b>6</b> | <b>Ball Valves</b><br>Manual Ball Valve Description and Features<br>Pneumatically Ball Valve Description and Features<br>Technical Data<br>Ordering Key   | 123<br>124<br>125 - 128<br>129   |
| <b>7</b> | <b>System Components and Process Automation</b><br><b>Overview</b><br>Manual Adjustment - Optical Indication<br>Electrical Switch Boxes - Pilot Control<br><b>Detailed Information</b><br>3/2 Way Plastic Pilot Valve<br>Control Head Switch 024.63. - 024.89.<br>Contact-Free Limit Switch 024.50<br><b>Process Automation, Electropneumatic Positioners</b><br><b>Overview Product Range</b><br><b>Glossary</b>                               | 132<br>133<br>134<br>135, 136<br>137<br>138, 139<br>140 - 143<br>144<br>145, 146 |

## Overview

| Description  | Type                       | Diaphragm size (MA) | Suitable for valve |                        |        | Detail see page |
|--|----------------------------|---------------------|--------------------|------------------------|--------|-----------------|
|  |                            |                     | Range              | Pneumatically operated | Manual |                 |
| Optical position indicator   | 024.10                     | 8 - 100             | DN 4 - 100         | ●                      | ●      | 133             |
| Stroke limiter   | 024.11                     | 8 - 100             | DN 4 - 100         | ●                      | ●      | 133             |
| Stroke Limiter with hand wheel   | 024.12.2                   | 8                   | DN 8 - 15          | ●                      |        | 133             |
| Stroke limiter with optical position indicator                                   | 024.12                     | 8 - 100             | DN 4 - 100         | ●                      | ●      | 133             |
| Manual override with optical position indicator                                  | 024.13                     | 8 - 50              | DN 4 - 50          | ●                      |        | 133             |
| Handwheel to open normally closed valves (NC) or close normally open valves (NO) | 024.42                     | 25 - 100            | DN 15 - 100        | ●                      |        | 133             |
| Contact - Free Limit Switch  | 024.50                     | 8 - 100             | DN 4 - 100         | ●                      |        | 134, 138, 139   |
| Control head switch with optical indicator "catch the eye"                       | 024.63<br>024.64<br>024.65 | 8 - 100             | DN 4 - 100         | ●                      |        | 134, 137        |
| Control head switch with "catch the eye" optical indicator AS - Interface        | 024.89                     | 8 - 100             | DN 4 - 100         | ●                      |        | 134, 137        |
| Limit switch with one mechanical switch and optical indicator                    | 024.90                     | 8 - 100             | DN 4 - 100         | ●                      | ●      | 134             |
| Pilot valve for direct mounting  | 600                        | 8 - 100             | 200 NL             | ●                      |        | 135             |
| Pilot valve for direct mounting  | 602                        | 8 - 100             | 60 NL              | ●                      |        | 136             |
| Pilot valve for manifold mounting  | 603                        | 8 - 100             | 60 NL              | ●                      |        | 136             |
| Pilot valve for manifold mounting  | 605                        | 8 - 100             | 200 NL             | ●                      |        | 135             |
| Manual valve prepared for mounting proximity switch                              | 024.96                     | 25 - 100            | DN 15 - 100        |                        | ●      |                 |
| Adapter for direct mounting one proximity direct on top in the valve actuator    | SO795                      | 8 - 100             | DN 4 - 100         | ●                      |        |                 |
| Travel stop  | 024.886                    | 8 - 100             | DN 4 - 100         | ●                      | ●      |                 |

System Components and Accessories are shown on page 133 - 139.

## Manual Adjustment - Optical Indication



024.11  
Stroke Limiter  
optional with cap



024.12.2  
Stroke Limiter  
with hand wheel



024.12  
Stroke Limiter  
with Optical Position  
Indicator  
optional with cap



024.13  
Manual Override  
with Optical  
Position Indicator



024.10  
Optical Position Indicator



024.42  
Handwheel to open normally  
closed valves (NC) or close  
normally open valves (NO)

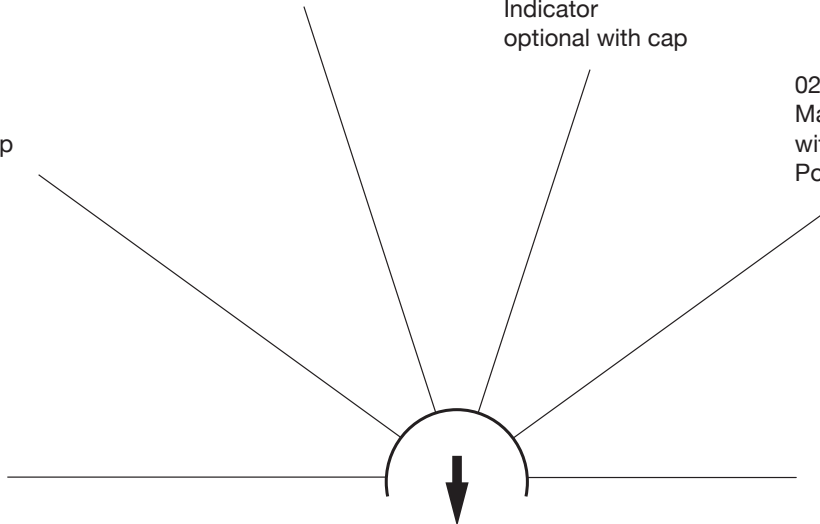

Upon request combinations of Manual Adjustments with Switch Boxes are available

## Electrical Switch Boxes - Pilot Control



024.50  
Contact - Free Limit Switch  
(See page 138 - 139)



024.90  
Limit Switch open position



603  
Pilot Valve for  
manifold mounting



024.63-024.65  
Control Head Switch for  
open and close with optical  
indicator catches the eye  
(See page 137)

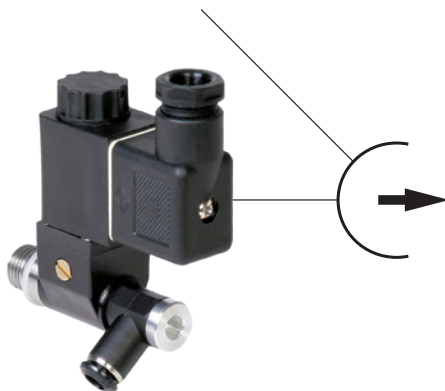

602  
Pilot Valve for  
direct mounting



024.89  
AS-Interface Control Head  
Switch for open and close  
position with optical indicator  
catches the eye  
(See page 137)

Upon request combinations of Manual Adjustments with Switch Boxes are available

## 3/2 Way Plastic Pilot Valve Type 600 / 605

### Description

Direct solenoid actuated poppet valve, normally closed and normally open, direct and manifold mounting. Solenoid valve for filtered, lubricated or non lubricated air, neutral gaseous and liquid fluids.

### Features

- Compact design
- Interchangeable solenoid system
- Plastic overmolded solenoid
- suited for coarse vacuum
- Exhaust port provided with silencer
- Standard manual override
- Current draw 5 W

### Type 600

Connections: Threaded socket 1/8" BSP. Inlet and Outlet arranged at an angle of 90°. Suitable for direct mounting on process valve, by hollow screw with 1/4" or 1/8" BSP thread.

### Type 605

Connections: threaded inlet G 1/4" outlet G 1/8". Inlet and outlet arranged at an angle of 90°. Suitable for manifold mounting. May also be used as a single valve.



### Technical Data

|                    |   |
|--------------------|---|
| Nominal size       | 1,6 mm                                  |
| Line connection    | G 1/8"                                  |
| Operating pressure | 0 - 10 bar                              |
| Flow rate          | Qn 200 l/min                            |
| Voltages           |   |
| AC                 | 24V40-60 Hz, 110V40-60 Hz, 220V40-60 Hz |
| DC                 | 12V, 24V, 48V, 100V, 110V, 200V         |

|                               |              |
|-------------------------------|--------------|
| Switching time appr.          | On 14 ms     |
|                               | Out 9 ms     |
| Current draw                  | 5W (6VA)     |
| Protection Class ICE/EN 60529 | IP 65        |
| Temperature range             | -10 to +60°C |
| AC                            | 210 g        |
| DC                            | PBT          |

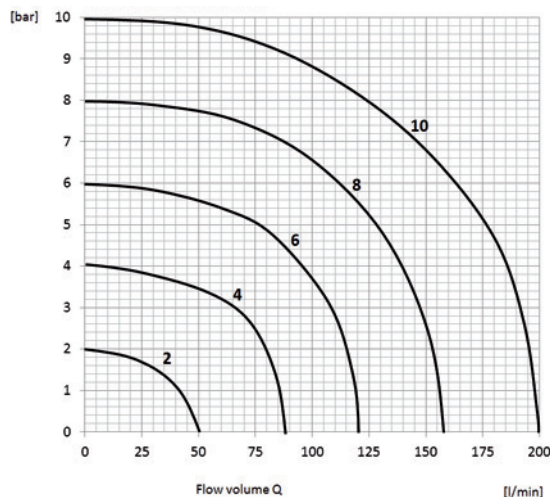

The diagram illustrates the flow rate for gases in normal litres per minute. For examples: inlet pressure 6 bar and pressure drop ( $\Delta p$ ) 2 bar. mark the point of intersection of the 6 bar curve and the horizontal line for 2 bar  $\Delta p$ . Move vertically from this point to the bottom scale and read off the flow rate in NL per minute.

## 3/2 Way Plastic Pilot Valve Type 602 / 603

### Description

The solenoid valves are electromagnetic, direct actuated pilot valves to control pneumatically operated valve actuators. Applicable media are filtered, lubricated or non lubricated air and neutral gaseous fluids.

Type 602 is equipped with a hollow screw and made for direct mounting on the user.

Type 603 is designed for manifold mounting, where a variable amount of single pilot valves are assembled together and connected to the pneumatically operated valve actuators by pneumatic lines.

### Features

- Compact design
- Identical position of all ports for version normally open and normally closed (except connection M5)
- Plastic wrapped electromagnet
- Interchangeable solenoid system
- 360° adjustable position of electromagnet
- Also suitable for coarse vacuum
- Silenced exhaust port
- Manual override (depending on version)
- Any installation position possible
- Cable plug can be mounted turned by 180°
- Combined exhaust optional
- Optional
  - ATEX-Version for explosion-risk areas
  - UL-approval
- Mounting rail for manifold mounting  
Type 603 available as option



**Type 602**

Banjo with push-in connection for tube Ø 6mm



**Type 602**

Banjo with threaded socket G1/8"



**Type 603**

Manifold assembly

### Standard versions

| Type                       | Cf. | Version                | Connection                       |                        |         | Manual-override | Fig. |
|----------------------------|-----|------------------------|----------------------------------|------------------------|---------|-----------------|------|
|                            |     |                        | P1                               | P2                     | P3      |                 |      |
| 602.1,2.32.24.2.1.S5.1.xx* | 1   | Direct mounting, Banjo | Push-in connection f. tube Ø 6mm | G1/8" or G1/4" Plunger |         | Yes             | 1    |
| 602.1,2.32.24.2.1.35.1.xx* | 1   | Direct mounting, Banjo | Threaded socket G1/8"            | G1/8" or G1/4" Plunger |         | Yes             | 1    |
| 602.1,2.32.24.2.2.S5.1.xx* | 2   | Direct mounting, Banjo | Push-in connection f. tube Ø 6mm | G1/8" or G1/4" Plunger |         | No              | 1    |
| 602.1,2.32.24.2.2.35.1.xx* | 2   | Direct mounting, Banjo | Threaded socket G1/8"            | G1/8" or G1/4" Plunger |         | No              | 1    |
| 602.1,2.32.24.2.2.M5.1.xx* | 2   | Direct mounting, Banjo | Thread M5 at plunger             | G1/8" or G1/4" G1/8"   |         | Yes             | 2    |
| 603.1,2.32.24.2.1.43.1.xx* | 1   | Manifold mounting      | Threaded socket G1/4"            | G1/8"                  | Plunger | Yes             | 3    |
| 603.1,2.32.24.2.2.43.1.xx* | 2   | Manifold mounting      | Threaded socket G1/4"            | G1/8"                  | Plunger | No              | 3    |

For detailed information please see TD130020



## Control Head Switch 024.63. - 024.89.

The SED electrical control head is an innovative development based on years of experience in manufacturing electrical accessories for process valves.

Depending on the version, the electrical control head provides signals for both open and closed positions of the valve and includes an integral solenoid valve for a direct air line connection to the actuator.

### Ease of Assembly:

Because of the design, the electrical control head is suitable for assembly with all linear valves. The threaded adapter of the electrical control head is designed to screw into the top of the valve actuator. A spring pushes the stem of the electrical control head onto the valve actuator stem. The spring allows for the electrical control head stem to follow freely the linear movement of the valve actuator stem. This electrical control head may be mounted on the valve actuator in the field without disassembly of any components.

### Self Positioning:

After mounting the electrical control head, the two cams activating the switches in the electrical control head will be mechanically moved by overcoming their holding force on the spindle. To adjust the closed position, the electrical control head stem will be pushed down until contact is made with the valve actuator stem.

The adjustment of the open position takes place at the first stroke of the valve. The circumferential optical indicator is suspended on the cam for the closed position and represents the entire stroke of the valve.

For the electrical connection a pre-wired pin or Bus-connection is available. The electrical control head has a reliable output and service life and contributes considerably to cost savings when considering assembly, application, and self adjustment as compared to other conventional control head options available.

### Features:

- Increased air flow rate 230 NI/min
- Circumferential catch the eye optical indicator representing the full stroke
- Ease of assembly and may be assembled with the valve actuator in the field
- Time saving electrical interface via pre-wired pin or a Bus-connection
- Compact design
- Position feedback versions with:
  - Electromechanical switch
  - Inductive initiators Namur or PNP
  - AS-Interface
- Suitable for mounting on linear valves
- Depending on the specification, LED indication is available

### Optional:

- Integral solenoid valve with direct air line connection to actuator
- Stroke limiter for the valve stroke adjustment

For more details see TD15 0094

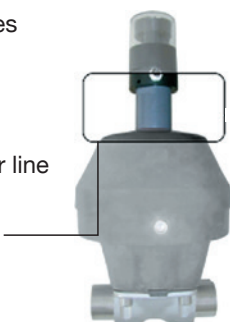

### Position valve open:

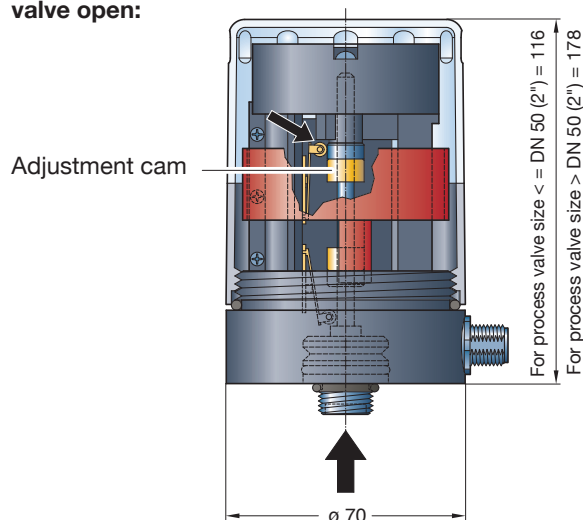

### Position valve closed:

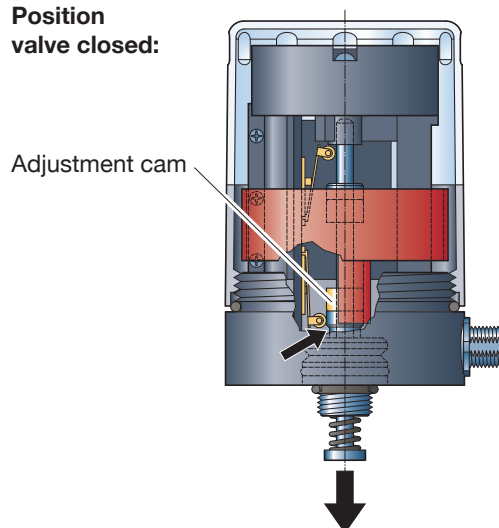

Versions Control Head

| Code                  | Electrical Connection    | Electro-mechanical limit switch Open/Close (pcs) | Proximity switch     |                    | Solenoid Valves <sup>1</sup> (pcs) |
|-----------------------|--------------------------|--|----------------------|--------------------|------------------------------------|
|                       |                          |  | Namur (2-wire) (pcs) | PNP (3-wire) (pcs) |                                    |
| 024.63.               | Pre-wired 8 pins M12 x 1 | 2  |                      |                    |                                    |
| 024.64.               | Pre-wired 8 pins M12 x 1 |  | 2                    |                    |                                    |
| 024.65.               | Pre-wired 8 pins M12 x 1 |  |                      | 2                  |                                    |
| 024.89.6 AS-Interface | Pre-wired 4 pins M12 x 1 | 2  |                      |                    | 1                                  |
| 024.89.7 AS-Interface | Pre-wired 4 pins M12 x 1 |  |                      | 2                  | 1                                  |

The ASI version offers the integral solenoid valve as standard.

<sup>1</sup> On request, two 3/2 way solenoid valves can be integrated for all versions.

## Contact - Free Limit Switch 024.50

Limit switches are used to control, monitor and view the position of the valve or to activate other system components.

There are different versions of on/off limit switches in the market. The most common are based on the principle of mechanical switches, proximity sensors or potentiometers.

SED has designed and engineered a contact-free limit switch with magnet field measurement technology. Apart from lifetime and among other features the advanced design allows also a more reliable sealing method.



Standard Version

### Features

- For single and double acting valve control functions
- Suitable for linear and rotary actuators
- Power supply and programming 24V DC or 8V DC
- Linear stroke measurement of 3-45 mm
- Indicates two or three positions
- Backlash free stroke transmission
- Short circuit proof
- M12, 5 pin A-coded connection

Optional:

- Atex II 3G
-  IO-Link

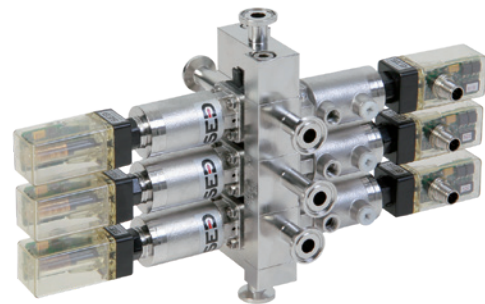

Application example

### Advantages

- Contact-Free magnetic measuring design
- Colored LED light feedback of valve position visible for 360°
- Compact and robust design
- Hermetically sealed
- Easy mounting without additional adapter kits
- Mounts to all standard valves up to DN100
- 360° adjustable mounting position
- Initial programming by light or 24V Signal (5th pin)
- Set point protection
- High switching current (not valid for IO-Link)
- High chemical resistance

## Contact - Free Limit Switch 024.50

### Technical Data

|                         |                                      |
|-------------------------|--------------------------------------|
| Material Housing        | PPSU                                 |
| Mechanical Adaption     | St. Steel M12x1, M16x1               |
| Ambient Temperature     | -10°C to + 70°C                      |
| Maximum Pressure        | 8 bar                                |
| Power Supply            | Standard and II 3G = 24V optional 8V |
| Power Consumption       | 0,7 W                                |
| Maximum Power Input     | 30 mA                                |
| Electrical Connection   | Multipol M12, 5 Pin, A-coded         |
| Switching Current       | 1 ... 800 mA                         |
| Stroke-/ Slewing- Range | 3 - 45 mm / 360°                     |
| Accuracy                | +/- 0,1 mm                           |
| Protection Class        | IP67 according EN 60529              |
| Conformity according CE | EMV 2014/30/EU                       |
| Mounting Position       | any                                  |
| Initialization          | Light or 24V Trigger/IO-Link         |

### Ordering Key

| Assembly Thread | Code                |                     |
|-----------------|---------------------|---------------------|
|                 | for Linear Actuator | for Rotary Actuator |
| M12x1           | 024.50.120          | n.a.                |
| M16x1           | 024.50.160          | 024.50.260          |

### Optical Position Feedback

| Position        | LED Indication   |  |
|-----------------|------------------|--|
| open            | permanent green  |  |
| interim, if any | permanent yellow |  |
| closed          | permanent blue   |  |
| moving open     | blinking green   |  |
| moving closed   | blinking blue    |  |

### Dimensional Drawing

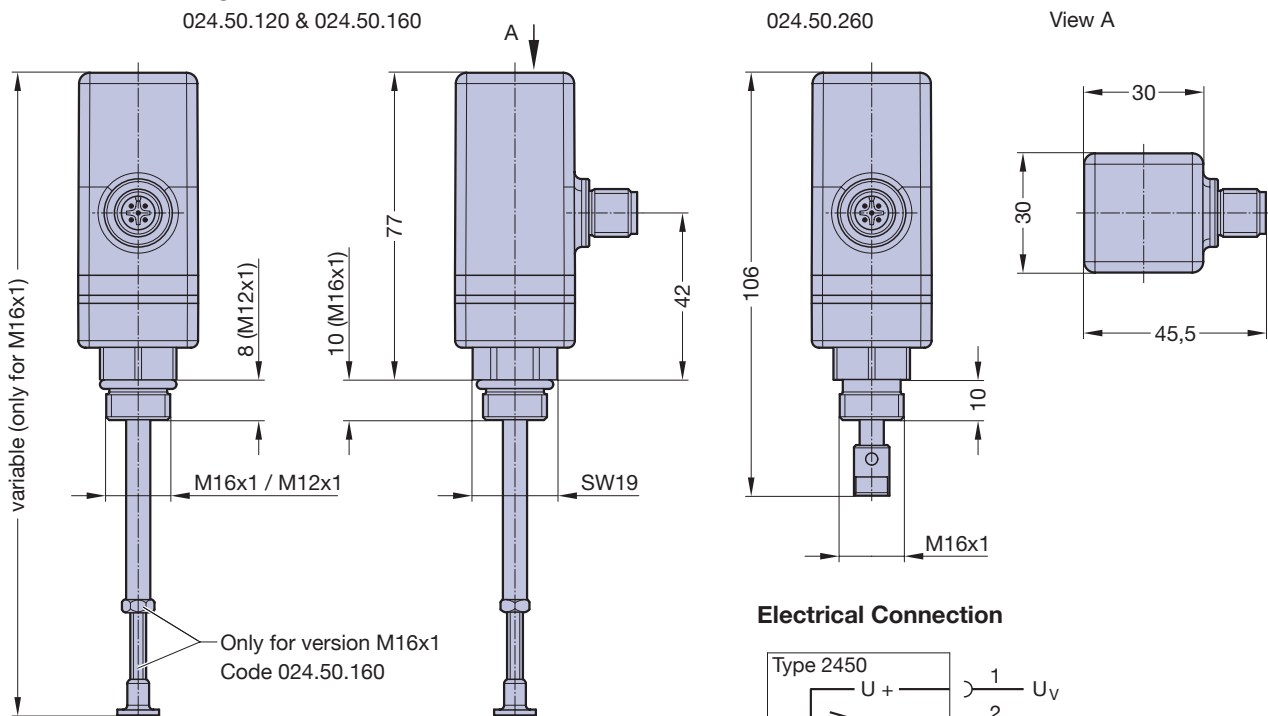

### Accessories

- 2 m cable with 4 pin female plug for explosion-risk areas, Code 00311.2450.006.4
- 5 m cable with 5 pin female plug, Code 00311.2450.006.1
- 10 m cable with 5 pin female plug, Code 00311.2450.006.2

### Optional

Teach-In cable for the programming via the 5<sup>th</sup> pin, Code 00311.2450.005

### Electrical Connection

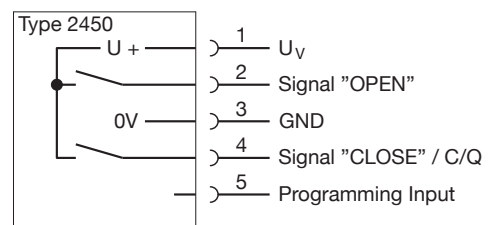

### Pin Configuration

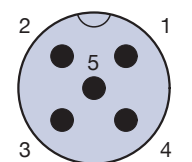

5 pin, M12, A-coded

## Electropneumatic Positioners ECOCENT 024.16.7

for central mounting on the top of the process control valves

### Main Features:

- Compact stainless steel, high performance plastic design
- Contact- free continuous sensor measuring of the valve spindle position
- Easy start up
- Pneumatic positioning for single acting actuators
- High air flow rate for type 024.16.720
- Close tight function

Type 024.16.720



Valve assembled with Positioner 024.16.710



| Type                       | 024.16.720  | 024.16.710 |
|----------------------------|-------------|------------|
| Recommended for valve size | DN 50 - 100 | DN 8 - 50  |

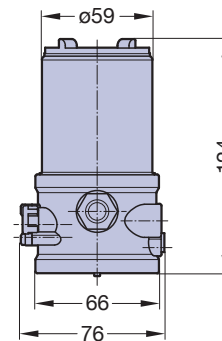
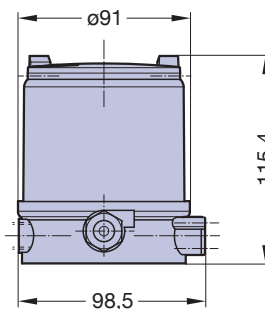

|                                       |   |   |
|---------------------------------------|---|---|
| Body; Cocer; Sealing                  | PPS/stainless steel; PC transparent; EPDM   | PPS/stainless steel; PC transparent; EPDM   |
| Ambient temperature                   | 0 - 55°C  | 0 - 55°C                                    |
| Control medium                        | Neutral gases, air according DIN ISO 8573-1   | Neutral gases, air according DIN ISO 8573-1 |
| Pilot air ports                       | G 1/8   | G 1/8                                       |
| Supply pressure;<br>Air flow rate     | 3 - 7 bar 1; 130 NI/min   | 1 - 7 bar 1; 7 NI/min                       |
| Intrinsic air consumption             | 0 l/min   | 0 l/min                                     |
| Power supply                          | 24 V DC +/- 10%   | 24 V DC +/- 10%                             |
| Power consumption                     | < 3,5 W   | < 3,5 W                                     |
| Electrical connection                 | Multipol M12 (8- pins), stainless steel   | Multipol M12 (8- pins), stainless steel     |
| Setpoint setting;<br>Input resistance | 4 to 20 mA; 180 Ohm   | 4 to 20 mA; 180 Ohm                         |
| Analogue feedback<br>4 - 20 mA        | Standard  | Optional                                    |
| Stroke range valve spindle            | 3 - 45 mm   | 3...28 mm                                   |
| Binary input                          | 0 - 5 V = log "0", 10 - 30 V = log "1"  | 0 - 5 V = log "0", 10 - 30 V = log "1"      |
| AS-Interface                          | optional  | NO  |
| Operation                             | 2 Key button  | 2 Key button                                |
| Visualisation                         | 2 LEDs  | 2 LEDs                                      |
| Protection class                      | IP65/67 according to EN 60529<br>(only if cables plugs and sockets have been connected properly and in compliance with the exhaust air concept in chapter "pneumatic connection of positioner") |   |
| Conformity                            | subject to CE according EMV2004/108/EG  | subject to CE according EMV2004/108/EG      |
| Approval                              | CSA on request.   | CSA on request.                             |
| Process controller                    | Optional  | NO  |

<sup>1</sup> Pressure stated in bar: are access to atmosphere; the supply pressure has to be 0,5 - 1 bar above the minimum required pilot pressure for the valve actuator

## Electropneumatic Positioner ECOSIDE 024.16.420

for process valves big stroke range and with remote control installation

### Main Features:

- Compact metal housing
- Contact- free continuous sensor measuring of the valve spindle position
- Simple start up using tune function
- Pneumatic positioning for single and double-acting actuators
- High air capacity
- Standardized for assembly according IEC 534-6 / VDI VDE 3845
- Available as remote version with position sensor
- Close tight function
- ATEX-Version available

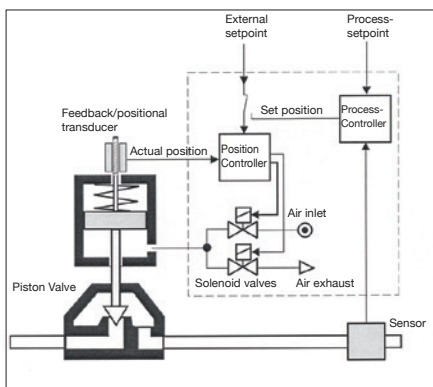
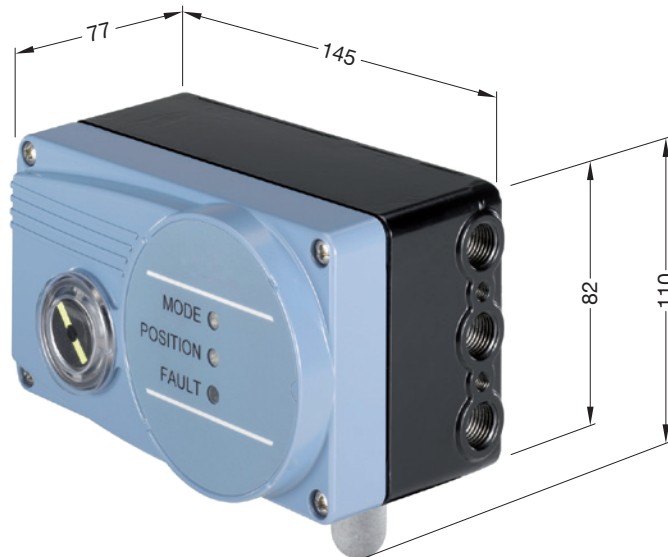

|                                 |  |
|---------------------------------|--|
| Type                            | 024.16.420   |
| Recommended for valve size      | DN25 - 200   |
| Body; Sealing                   | Aluminum plastic coated; EPDM  |
| Ambient temperature             | 0 - 60°C   |
| Control medium                  | Neutral gases, air according DIN ISO 8573-1  |
| Pilot air ports                 | G 1/4  |
| Supply pressure                 | 1,4 - 7 bar <sup>1)</sup>  |
| Air flow rate                   | Single and double-acting up to 150 NI/min<br>( $Q_{Nn} = 100$ NI/min acc. Definition with decrease in pressure from 7 to 6 bar absolute) |
| Intrinsic air consumption       | 0 l/min  |
| Power supply                    | 24 V DC +/- 10%  |
| Power consumption               | < 3,5 W  |
| Electrical connection           | M12 (8 Pins)   |
| Cable gland                     | 2 x M20 x 1,5 (cable Ø 10 mm) on screw terminal  |
| Remote version                  | 1 x M12 x 1,5 (cable Ø3 to 6,5 mm)   |
| Setting point; input resistance | 4 to 20 mA / 180 Ohm (0 - 20 mA adjustable with configuration software)  |
| Binary Input                    | 0 - 5 V = log "0", 10 - 30 V = log "1"   |
| Stroke range valve spindle      | Min. 30° on the rotary shaft, depending on lever   |
| Operation                       | 2 Key button   |
| Visualisation                   | 3 LEDs   |
| Protection class                | IP65/67 acc. EN 60529  |
| Type of ignition protection     | II 3 G nA II B T4<br>II 3 D tD A22 T135°   |
| Conformity                      | EMV2004/108/EG   |
| Approval                        | CSA  |
| Optional                        | Process controller<br>Analogue feedback 4 - 20 mA<br>AS-Interface  |

1) Pressure stated in bar: are access to atmosphere;

the supply pressure has to be 0,5 - 1 bar above the minimum required pilot pressure for the valve actuator

## Electropneumatic Positioners ECOSIDE 024.16.402

for process valves big stroke range and with remote control installation

### Main Features:

- Compact and robust metal housing
- Simple start up using tube function
- Pneumatic positioning for single and double-acting actuators
- High air capacity
- Close tight function
- ATEX approval II 2 (1) G Ex ia IIC T6 Gb

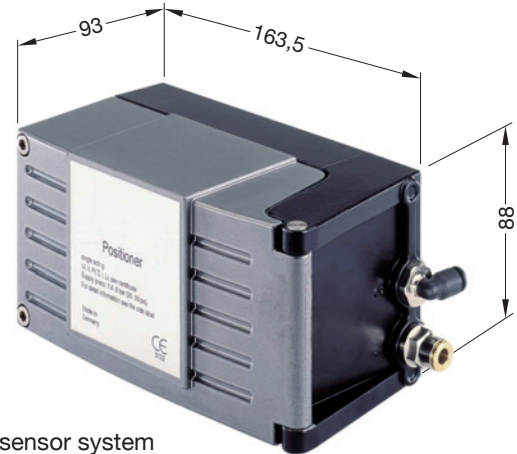

Assembly exclusively with position sensor system

| Type                            | 024.16.402   |
|---------------------------------|--|
| Body; Sealing                   | Aluminium, hard anodized and plastic coated  |
| Ambient temperature             | -25 ... +60 °C <sup>1)</sup>   |
| Control medium                  | neutral gases, air according DIN ISO 8573-1  |
| Pilot air ports                 | G 1/4  |
| Supply pressure                 | 1.4 - 6 bar <sup>3)</sup>  |
| Air flow rate                   | 55 l/min at 1.4 bar <sup>3)</sup><br>170 l/min at 6 bar <sup>3)</sup> for pressurizing and venting       |
| Intrinsic air consumption       | 0 l/min  |
| Power supply                    | via setpoint input 4-20mA  |
| Burden voltage                  | < 12 VDC   |
| Burden resistance               | 590 Ω at 20mA and 11.8 VDC   |
| Electrical connection           | 2 x M20 x 1.5-bushing<br>Clamping range 6 ... 12 mm<br>Screw terminals for 0.14 ... 1.5 mm <sup>2)</sup> |
| Remote version                  | available (only with the approved sensor)  |
| Setting point; input resistance | 4 ... 20 mA; 590 Ω   |
| Binary Input                    | mechanical NC/ NO contact  |
| Positioning range               | Linear actuator: 3... 130 mm<br>Part-turn actuator: 0... 120 °   |
| Operation                       | 3 operating keys   |
| Visualisation                   | Plain-text display (internal)  |
| Protection class                | IP65 acc. to EN 60529  |
| Type of ignition protection     | II 2 (1) G Ex ia IIC T6 Gb acc. to EN 60079-0:2012 and EN 60079-11:2012                                  |
| Conformity                      | EMC 2004/108/EC  |
| Approvals                       | ATEX EEx ia II C T6  |
| Certification                   | PTB 04 ATEX 2027 / IECEx PTB 04.0016   |
| Optional                        | Analogue feedback 4 - 20 mA<br>Process value input (4... 20mA)<br>Use in the Ex area (Zone 1)            |
| Assembly                        | Assembly set required  |

1) Up to +65 °C temperature class T4/T5 or without EEx i approval.

2) May be adapted to actuator size with throttle screw.

3) Pressure data in bar; overpressure to ambient.

## Electropneumatic Positioner 024.16.251

### Main Features:

- Three touch-sensitive keys and display for convenient operation
- Intuitive operation with simple menu navigation
- Automatic initialization
- UV-resistant housing
- Various attachment options
- Protected non-contact sensor for precise control
- ATEX approval II 2 G Ex ia IIC T4 Gb



| Type                            | 024.16.251   |
|---------------------------------|--|
| Recommended for valve size      | MA 25 - MA 100 (other sizes on request)                |
| Body; Sealing                   | Housing Polyhtalamid (PPA); Top Polycarbonat (PC); PUR |
| Ambient temperature             | -20°C to 80°C  |
| Control medium                  | Neutral gas; air according to DIN ISO 8573-1           |
| Pilot air ports                 | G1/4 or 1/4 NPT  |
| Supply pressure                 | up to 7 bar  |
| Air flow rate                   | at dp 6 bar 140 NI/min                                 |
| Intrinsic air consumption       | <= 100 NI/h.   |
| Power supply                    | 24 VDC +/- 10%   |
| Power consumption               | approx. 0,5 W  |
| Electrical connection           | Terminal connection block                              |
| Cable gland                     | M20x1,5  |
| Setting point; input resistance | 4-20 mA; 315 Ohm                                       |
| Stroke range valve spindle      | 3,75-50 mm   |
| Operation                       | 3 capacitive buttons                                   |
| Visualisation                   | LCD-Display  |
| Protection class                | IP66   |
| Type of ignition protection     | II 2G Ex ia IIC T4                                     |
| Conformity                      | EMV/2004/108/EG  |
| Approval                        | EAC  |
| Optional                        | Pressure gauge   |

# Overview Product Range

## Diaphragm Valve



Aseptic Diaphragm Valve



Industrial Metal Diaphragm Valve



Plastic Diaphragm Valve

## Angle Seat Valve



Two-Way Metal Angle Seat Valve

## Aseptic Process Solution



Sterile sampling unit

## System Components



Contact - Free Limit Switch



Control Head



Digital Electropneumatic Positioner

## Flow Measurement



Variable Area Flowmeter



Measuring Sensor



| Term  | Acronym          | Definition   |
|---|------------------|--|
| 3A Sanitary Standards and Accepted Practices  | <b>3A</b>        | Determines criteria for the cleanability of dairy processing equipment. They have been adopted by many other liquid processing industries outside of dairy.  |
| Active Pharmaceutical Ingredients             | <b>API</b>       | A substance used in a finished pharmaceutical product (FPP), intended to furnish pharmacological activity or to otherwise have direct effect in the diagnosis, cure, mitigation, treatment or prevention of disease, or to have direct effect in restoring, correcting or modifying physiological functions in human beings.           |
| American Society of Mechanical Engineers      | <b>ASME</b>      | Creates consensus standards for Mechanical Engineering   |
| American Society for the Testing of Materials | <b>ASTM</b>      | Creates consensus standards for material quality and material quality testing methods.   |
| Approved for Construction                     | <b>AFC</b>       | An Approved for Construction (AFC) means that drawings and documents are reviewed and approved by authorities of internal and external organisations including the client team members for the construction. A Construction team must use only AFC marked or stamped drawings and documents for the construction works and activities. |
| BioProcessing Equipment Committee             | <b>BPE</b>       | A sub-committee of ASME. It creates engineering standards for the design, specification, manufacture and documentation of equipment used for biopharm processes.   |
| Clean in Place                                | <b>CIP</b>       | The technique of cleaning process line components without the need for relocation or disassembly.  |
| Circumferential Defined Sealing Angle         | <b>CDSA</b>      | Circumferential Defined Sealing Angle (CDSA-Design) SED sealing concept Innovation by SED Flow Control   |
| Comite Européen de Normalisation              | <b>CEN</b>       | Committee for European Standardization<br>Creates standards that reflect the best practices in each industry and is supported by DIN and ISO.  |
| Current Good Manufacturing Practices          | <b>cGMP</b>      | Current design and operating practices developed by the pharmaceutical industry to meet FDA requirements as published in the Code of Federal Regulations. They reflect the least common denominator of practices in the industry at present.   |
| Deionized Water                               | <b>DIW</b>       | Process of the extraction of deionized water through ion exchange resins.  |
| Deutsches Institut für Normung                | <b>DIN</b>       | German Institute for Standardization<br>Creates engineering standards for Germany and is contributing body to CEN and ISO.   |
| Design Qualification                          | <b>DQ</b>        | Design Qualification is used at the stage where a design that has been developed from the, VMP / URS /GAMP 5 / cGMP / and other Health and Safety Guidelines, is reviewed and documented by competent persons to ensure that the designed equipment, if built, will satisfy all the detailed specified requirements.                   |
| Electro-Polish                                | <b>EP or E/P</b> | Electrochemical polishing process for metal components where metal ions are removed from the surface of the metal.   |
| European Hygienic Equipment Design Group      | <b>EHEDG</b>     | The group's objective is to provide standardization organizations (CEN and ISO) with specialist views on hygienic and aseptic design by publishing requirements and test methods. Accredited bodies carry out cleaning tests which are certified if successful.  |
| European Pharmacopoeia                        | <b>EP</b>        | European counterpart to USP. A private, non-profit organization that sets standards for drugs, drug ingredients, medical devices and diagnostics.  |
| Engineering, Procurement, and Construction    | <b>EPC</b>       | Engineering, Procurement, and Construction" is a particular form of contracting arrangement used in some industries where the EPC Contractor is made responsible for all the activities from design, procurement, construction, to commissioning and handover of the project to the End-User or Owner.                                 |
| Factory Acceptance Test                       | <b>FAT</b>       | Is usually performed at the vendor prior to shipping to a client. The vendor tests the system in accordance with the clients approved test plans and specifications to show that system is at a point to be installed and tested on site.  |



# Glossary

---

| <b>Term</b>  | <b>Acronym</b>  | <b>Definition</b>  |
|--|-----------------|--|
| Food and Drug Administration (USA)                   | <b>FDA</b>      | Enforcement agency of the U.S. Government for food, drug and cosmetics manufacturing. Author of the U.S. cGMP's. Responsible for new product approvals, plant inspections and product recalls.   |
| International Standards Organization                 | <b>ISO</b>      | Creates consensus standards for engineering and quality systems.   |
| International Society for Pharmaceutical Engineering | <b>ISPE</b>     | The world's largest not-for-profit association serving its Members by leading scientific, technical and regulatory advancement throughout the entire pharmaceutical lifecycle.   |
| Installation Qualification                           | <b>IQ</b>       | The Installation Qualification Protocol verifies the proper installation and configuration of a System.  |
| Mill Test Report or Material Test Report             | <b>MTR</b>      | A document certifying the composition of a metal from a particular heat batch.   |
| Operational Qualification                            | <b>OQ</b>       | The Operational Qualification Protocol is a collection of test cases used to verify the proper functioning of a system.  |
| Performance Qualification                            | <b>PQ</b>       | Performance Qualifications are a collection of test cases used to verify that a system performs as expected under simulated real-world conditions.   |
| Piping and Instrumentation Diagram                   | <b>P&amp;ID</b> | American standard for process diagrams<br>Diagrams on which the process, the instruments and the flow scheme are defined   |
| Point of Use   | <b>POU</b>      | A valve outlet in a recirculation utility system (typically a water system).   |
| Purified Water                                       | <b>PW</b>       | Ingredient water (not for injection) or rinse water for pharmaceutical products conforming to USP guidelines. Obtained by distillation, reverse osmosis, ion exchange or any other suitable process.                                       |
| Site Acceptance Test                                 | <b>SAT</b>      | A SAT is a Site Acceptance Test the system is tested in accordance to client approved test plans and specifications to show the system is installed properly and interfaces with other systems and peripherals in its working environment. |
| Steam in Place                                       | <b>SIP</b>      | Sanitization of process line components by the use of steam without the need for relocation or disassembly.  |
| Total Oxidizable Carbon or Total Organic Carbon      | <b>TOC</b>      | A measure of the amount of organic compounds in a water sample. Carbon is oxidized and the level of CO <sub>2</sub> is measured. The proposed USP water standards are based on TOC analysis.   |
| United States Pharmacopoeia                          | <b>USP</b>      | A private, non-profit organization that sets standards for drugs, drug ingredients, medical devices, and diagnostics. The FDA enforces the established standards.  |
| User Requirement Specification                       | <b>URS</b>      | The User Requirements Specification describes the business needs for what users require from the system. User Requirements Specifications are written early in the validation process, typically before the system is created.             |
| Water for Injection                                  | <b>WFI</b>      | Water for use as a solvent for the preparation of parenteral products conforming to USP guidelines. Obtained most commonly by distillation.  |

## Website



<http://www.sed-flowcontrol.com/en/>

## Product Configurator



<http://www.sed-flowcontrol.com/en/configurator/>

- Easy **configuration of products** live on the screen
- Automatic creation of **CAD- files** in various file formats
- Send request and download product descriptions

## Manual diaphragm valve type 905



<http://www.sed-flowcontrol.com/en/service/movies>

## Contact - Free Limit switch 024.50



<http://www.sed-flowcontrol.com/en/service/movies>

# SAMSON AT A GLANCE

## STAFF

- Worldwide 4,300
- Europe 3,300
- Asia 500
- Americas 200
- Frankfurt am Main, Germany 1,800

## MARKETS

- Chemicals and petrochemicals
- Power and energy
- District heating and cooling, building automation
- General industry
- Industrial gases
- Food and beverages
- Metallurgy and mining
- Oil and gas
- Pharmaceuticals and biotechnology
- Marine equipment
- Water and wastewater
- Pulp and paper

## PRODUCTS

- Valves
- Self-operated regulators
- Actuators
- Valve accessories
- Signal converters
- Controllers and automation systems
- Sensors and thermostats
- Digital solutions

## SALES SITES

- More than 50 subsidiaries in over 40 countries
- More than 200 representatives

## PRODUCTION SITES

- SAMSON Germany, Frankfurt, established 1916  
Total plot and production area: 150,000 m<sup>2</sup>
- SAMSON France, Lyon, established 1962  
Total plot and production area: 23,400 m<sup>2</sup>
- SAMSON Turkey, Istanbul established 1984  
Total plot and production area: 11,053 m<sup>2</sup>
- SAMSON USA, Baytown, TX, established 1992  
Total plot and production area: 9,200 m<sup>2</sup>
- SAMSON China, Beijing, established 1998  
Total plot and production area: 10,138 m<sup>2</sup>
- SAMSON India, Pune district, established 1999  
Total plot and production area: 18,000 m<sup>2</sup>
- SAMSON Russia, Rostov-on-Don, established 2015  
Total plot and production area: 5,000 m<sup>2</sup>
- SAMSON AIR TORQUE, Bergamo, Italy  
Total plot and production area: 27,684 m<sup>2</sup>
- SAMSON CERA SYSTEM, Hermsdorf, Germany  
Total plot and production area: 14,700 m<sup>2</sup>
- SAMSON KT-ELEKTRONIK, Berlin, Germany  
Total plot and production area: 1,060 m<sup>2</sup>
- SAMSON LEUSCH, Neuss, Germany  
Total plot and production area: 18,400 m<sup>2</sup>
- SAMSON PFEIFFER, Kempen, Germany  
Total plot and production area: 35,400 m<sup>2</sup>
- SAMSON RINGO, Zaragoza, Spain  
Total plot and production area: 18,270 m<sup>2</sup>
- SAMSON SED, Bad Rappenau, Germany  
Total plot and production area: 10,370 m<sup>2</sup>
- SAMSON STARLINE, Bergamo, Italy  
Total plot and production area: 26,409 m<sup>2</sup>
- SAMSON VETEC, Speyer, Germany  
Total plot and production area: 27,090 m<sup>2</sup>



SED Flow Control GmbH  
Am Schaffbaum 2 · 74906 Bad Rappenau, Germany  
Phone: +49 7264 921 0 · Fax: +49 7264 921 21  
E-mail: [info@sed-flowcontrol.com](mailto:info@sed-flowcontrol.com) · Internet: [www.sed-flowcontrol.com](http://www.sed-flowcontrol.com)